

APPLIED SYSTEMS

Product Catalogue 2017



| CHILLERS | HEAT PUMPS | FAN COILS | TERMINAL UNITS |
| SOLUTIONS TO CONTROL THE INTEGRATED SYSTEM |







➔ April 2017



FullPOWER

Controlled power
and efficiency!

An Eco-friendly solution

- Reduced refrigerant load
- Low GWP option - HFO gas
- High energy efficiency at partial loads in the VFD range
- Low consumption
- LEED compliant unit

Guaranteed performance

- Eurovent Certification
- Thorough testing in the Rhoss R&D laboratory
- Extended operating field

Full optional range

- Pumping units and recovery units for plug&play solutions
- Accessories for intelligent management with energy saving logic





INVERTER

VPF
VARIABLE PRIMARY FLOW

BRUSHLESS
EC



FullPOWER VFD

High efficiency units with screw compressors with variable Vi and inverter regulated rotation. The innovative components used help guarantee efficiency both at full load and partial load with virtually unbeatable ESEER and SEER values. All models are available with power from 500 to 1000 kW and in various versions, thereby making them an excellent solution for today's HVAC applications!



FullPOWER

Plug&play unit with top quality components

Chillers must increasingly use plug&play in the system; FullPOWER is the right solution, along with the countless features and options with which it can be fitted. Pumping units, including inverter operated ones, partial or total heat recovery units and energy saving accessories make FullPOWER a range that adapts to any type of system and requirement. Using cutting edge components like MCHX micro-channel coils enhances unit performance, optimises heat exchange, and reduces refrigerant gas content consumption by up to 30%.



FullPOWER SE and HE-A

300 to 1300 kW units in the standard or high efficiency version (class A Eurovent) designed to produce chilled water with semi-hermetic screw compressors and R134a refrigerant. Available in several versions, including super-silenced equipped with brushless EC fans that meet acoustic comfort requirements while ensuring low operating costs and rapid return on investment.

Rhoss presents FullPOWER and FullPOWER VFD, the new generation of chillers with air cooled screw compressors in R134a, designed to offer efficient, versatile and technologically advanced solutions to meet modern HVAC (Heating Ventilation and Air Conditioning) system requirements.

Available in different versions, the entire range complies with the most stringent environmental standards in terms of energy efficiency and limited greenhouse gas content, offering low noise solutions.

If the goal is to eliminate environmental impact, the FullPOWER ECO range with R1234ze gas is the solution of the future.

➔ June 2017



TurboPOWER

Technology and efficiency in continuous evolution

An Eco-friendly solution

- Reduced refrigerant load
- Low GWP option - HFO gas
- High energy efficiency at partial load
- Precise and efficient load modulation
- LEED compliant units

Guaranteed performance

- Eurovent Certification
- Validation testing in the Rhoss R&D laboratory
- Thorough operation
- Advanced control logic

Full optional range

- Pumping units and functions for plug&play solutions
- Accessories for intelligent management with energy saving logic





TurboPOWER

High efficiency units (exceeding Eurovent class A) designed to produce chilled water with OIL-FREE centrifugal compressors and innovative components make the TurboPOWER ranges an excellent solution in modern HVAC applications.

Efficiency and silence are the main features of this range and the 10 models in the various versions allow over 1000 kW to be reached with top notch ESEER and SEER values.

TurboPOWER

Plug&Play Unit

Chillers must increasingly use plug&play in the system; the TurboPOWER design in the right solution, along with the countless features and options with which it can be fitted.

The requirements of pumping units, including inverter controlled ones, are combined with precise, efficient and silent modulation requirements with Brushless EC fans.

If condensation heat needs to be partially recovered, or the coils simply need processing, or the unit needs to be protected with netting or aesthetic finishing panels, there are several options.

Special attention was given to further reducing noise, limiting power consumption or monitoring, connecting, and supervising the chiller with BMS systems.

TurboPOWER

Components of excellence

In addition to the TURBOCOR centrifugal core, the units are equipped with cutting edge, performance enhancing flooded heat exchangers.

MCHX micro-channel coils optimise heat exchange and make the chiller lighter, with the refrigerant gas content further reduced by up to 30%.

The unit management software, designed and engineered by technical experts, enables precise, accurate temperature control of the water produced to ensure better system service with the option of connecting several units in parallel.

Rhoss presents TurboPOWER, the new generation of air cooled chillers with Oil-free centrifugal compressors in R134a, designed to offer efficient, versatile and, technologically advanced solutions to meet modern HVAC (Heating Ventilation and Air Conditioning) system requirements.

Available in different versions, the entire range complies with the most stringent environmental standards in terms of energy efficiency and limited greenhouse gas content, offering low noise solutions.

If the goal is to eliminate environmental impact, the TurboPOWER ECO range with R1234ze gas is the solution of the future.

Inverter scroll compressors



ELECTA
3,8÷12,6 kW
Web code: EL001
PAGE 28



Compact-I
16,4÷27,6 kW
Web code: CYI01
PAGE 34



Compact-I MD
34,3÷58,3 kW
Web code: CYI11
PAGE 40

Hermetic scroll compressors



Mini-Y
5,6÷11,3 kW
Web code: MY001
PAGE 30

Mini-Y NF
5,6÷11,3 kW
Web code: MYN01
PAGE 32



Compact-Y MD
33,8÷63,7 kW
Web code: CY011
PAGE 42



POKER
28,8÷115,2 kW
Web code: PK001
PAGE 44



Compact-Y NF
15,5÷26,6 kW
Web code: CYP01
PAGE 36

Compact-Y SM
15,7÷29,5 kW
Web code: CY001
PAGE 38



Y-Pack FREECOOLING
170÷361 kW
Web code: YKF11
PAGE 54

Semi-hermetic screw compressors



FullPOWER
PAGE 2



Z-Power HE
315,4÷1.277,7 kW
Web code: ZPE01
PAGE 64

Z-Power SE
259,1÷1.609,7 kW
Web code: ZP001
PAGE 68

Oil-free centrifugal compressors



TurboPOWER
PAGE 4



Hermetic scroll compressors



Mini-Y C
4,9÷10,6 kW
Web code: MYC01
PAGE 82



Compact-Y C
13,3÷26,6 kW
Web code: CYC01
PAGE 84



Y-Pack C-PF
32,3÷160,2 kW
Web code: YKC01
PAGE 86

Hermetic scroll compressors Water cooled



Comby-Flow
5,5÷12,2 kW
Web code: CF001
PAGE 90



Y-Flow
15,5÷41,7 kW
Web code: YF011
PAGE 92



Z-Flow
41,2÷448,8 kW
Web code: 245÷2185: YF021 - Web code: 4180÷4450: YF031
PAGE 94

Semi-hermetic screw compressors



Z-Flow HE
203,3÷1.627,6 kW
Web code: ZFE01
PAGE 96



Z-Flow SE
198,8÷1.624,5 kW
Web code: ZF001
PAGE 98

903
kW

Inverter screw compressors



 **Z-Power VFD**
516÷903 kW
Web code: ZPV01
PAGE 74



FullPOWER VFD
PAGE 2



917
kW

new



  **EasyPACK**
63,7÷144,4 kW
Web code: EAS01
PAGE 46





  **WinPACK HE-A**
91,6÷345 kW
Web code: WKE11
PAGE 48

  **WinPACK SE**
97,6÷328,6 kW
Web code: WK011
PAGE 50

new



  **WinPOWER HE-A**
337,3÷916,8 kW
Web code: WPE11
PAGE 56

 **WinPOWER SE**
335÷861,8 kW
Web code: WP011
PAGE 60

1600
kW



 **Z-Power FREECOOLING**
469÷1.216 kW
Web code: ZPF01
PAGE 76



 **Z-Power HP**
382,6÷677,6 kW
Web code: ZPP01
PAGE 78

1360
kW

Hermetic scroll compressors
Condenserless units



 **Y-Flow E**
13,7÷36,9 kW
Web code: YFC11
PAGE 100



 **Y-Flow E**
39,8÷320,9 kW
Web code 245÷2185: YFC21 - Web code 4180÷4360: YFC31
PAGE 102

1628
kW



 **Z-Flow E**
171,9÷1.424,8 kW
Web code: ZFC01
PAGE 104



ONLY COOLING



HEAT PUMP



POLYVALENT SYSTEMS

Hermetic scroll compressors

18 kW



Compact-Y EXP SM
17,7÷29,1 kW
Web code: CYX11
PAGE 108



Compact-Y EXP MD
33,8÷61,6 kW
Web code: CYX21
PAGE 110



Y-Pack EXP
81÷334 kW
Web code: YKX11
PAGE 112

Semi-hermetic screw compressors

408 kW



Z-Power EXP
408÷698 kW
Web code: ZPX01
PAGE 116

Hermetic scroll compressors

5 kW



Comby-Flow EXP
5,5÷12,2 kW
Web code: CFX01
PAGE 118



Y-Flow EXP
47÷462,6 kW
Web code 245÷2185: YFX21 - Web code 4180÷4450: YFX31
PAGE 120

463 kW

Semi-hermetic screw compressors

434 kW



Z-Flow EXP
434÷782 kW
Web code: ZFX01
PAGE 122



16,4÷31,5 kW
Web code: CUY01
PAGE 126

16 kW



34,5÷162,6 kW
Web code: CUY11
PAGE 127

163 kW

WALL MOUNTING INSTALLATION

FLOOR, CEILING, RECESSED WALL OR FALSE CEILING INSTALLATION

Inverter Brushless motor



IDROWALL-I
2,0÷3,5 kW
Web code: IDRO1
PAGE 158



YARDY-I EV3
1,9÷8,6 kW
Web code: YARI3
PAGE 160

Standard motor



YARDY EV3
1,1÷8,5 kW
Web code: YARV3
PAGE 162

650 kW



R410A
WinPOWER EXP
362÷650 kW
Web code: WPX01
PAGE 114

698 kW

782 kW

System accessories

Remote condensers

Cooling towers

Pumping units and water tanks

PAGE 129



R410A
23÷218 kW
Web code Mod. 115÷240: CRYA1
Mod. 245÷2185: CRYA2
PAGE 130



47÷2790 kW
Web code: TEA01
PAGE 134



300÷2500 l
Web code: GPA01
PAGE 136



200÷425 l
Web code: GPH01
PAGE 138

DUCTED INSTALLATION

FALSE CEILING CASSETTE



YARDY-ID2
2,4÷6,4 kW
Web code: YAID2
PAGE 166



DIVA-I
2,8÷10,8 kW
Web code: DIVI1
PAGE 172



YARDY-DUCT2
2,0÷5,8 kW
Web code: YADC2
PAGE 168



YARDY-HP
7,2÷20,5 kW
Web code: YAHP1
PAGE 170



DIVA
2,0÷11,1 kW
Web code: DIVA1
PAGE 174



VTNC
2,9÷7,8 kW
Web code: VTNC1
PAGE 176



ONLY COOLING



HEAT PUMP



POLYVALENT SYSTEMS

CONTROLS FOR HEAT-PUMP SYSTEMS



RHOSS TOUCH MANAGER

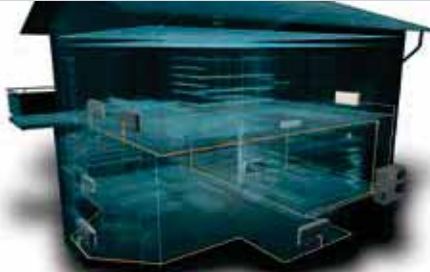

IDRHOSS



RHOSS MONITORING:
Mobile - Cloud - Real time



RHOSS WEB SERVER



SIR - RHOSS INTEGRATED SEQUENCER - PAGE 154

RHOSS SEQUENCER - PAGE 155



RHOSS SUPERVISOR





ErP
READY
2018

APPLIES TO
EUROPEAN
DIRECTIVE
FOR ENERGY
RELATED
PRODUCTS

Terminal unit
UTNA Platinum
6,4÷70 kW
Web code: UTAP1
PAGE 182

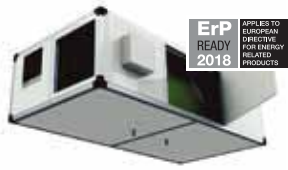

ErP
READY
2018

APPLIES TO
EUROPEAN
DIRECTIVE
FOR ENERGY
RELATED
PRODUCTS

Heat recovery unit
UTNR-A Platinum
Counterflow heat recovery
400÷4.050 m³/h
Web code: UTNR3
PAGE 186



ErP
READY
2018

APPLIES TO
EUROPEAN
DIRECTIVE
FOR ENERGY
RELATED
PRODUCTS

Heat recovery unit
UTNR-HE Platinum
Rotative heat recovery
310÷4.250 m³/h
Web code: UTHE3
PAGE 190



Heat recovery unit
UTNR-HP
Thermodynamic heat recovery
350÷4.500 m³/h
Web code: UTHP1
PAGE 198



ErP
READY
2018

APPLIES TO
EUROPEAN
DIRECTIVE
FOR ENERGY
RELATED
PRODUCTS

Heat recovery unit
VMC-E
Counterflow heat recovery
250÷1.000 m³/h
Web code: VMCO1
PAGE 200



Since 1963, IRSAP has been a leader in the production of steel tubular radiators. IRSAP is the core of the Group: it combines the heat of fire with a burning passion for well-being.



Since 1968, RHOSS has worked in the public and industrial air conditioning sector.

RHOSS is a breath of fresh air for your body and mind, thanks to products and systems that innovate air conditioning.



CREATING YOUR COMFORT

“Being a united industrial group of companies operating in an international market in strong partnership with its customers. With a team of motivated people, we find and create the “solution” for every heating and cooling requirement through innovative integrated systems. Our objective is to create perfect comfort that guarantees wellbeing to the person in his habitat whilst respecting the environment”.

Established as one of the most valued groups in the sector, acquiring a strong and recognisable image of technological leadership, investing in constant research and development, adopting the most innovative technological solutions, are our mission.

Our strategy is to create value through growth and international expansion, especially in emerging markets, diversifying and specializing the offer also through the acquisition of new skills and external production companies.

Our objective is to respond to new market needs dynamically and flexibly by orienting the range towards advanced and competitive products, integrated systems and services to higher efficiency and low environmental impact, pursuing an optimal relationship between macroclimate and microclimate.

RHOSS: a product range to achieve **LEED**[®] credits

The **LEED**[®] standard was developed in the USA in 1998 by the U.S. Green Building Council (USGBC), which is a non-profit organisation that promotes and offers a global approach towards sustainability, recognising virtuous performance in key areas of health regarding mankind and the environment.

LEED[®] is a voluntary system based on consent to design, construct and manage high-performance green buildings, and the system is constantly developing on an international level. It can be used on any type of building and promotes an integrated design system that concerns the entire building.

LEED[®] is a flexible system that can be applied to all types of buildings - commercial, residential, and neighbourhoods, and is based on the entire life cycle of the building from design and construction to management and maintenance.

It is a certification protocol for buildings that is redefining the way we think of the places where we live, work, and study.

It is internationally recognised as a symbol of excellence.

It offers building owners and operators a reference point to identify and implement sustainable measurable design, construction, and management.



Guide to the LEED principles **LEED**[®]
Leadership in Energy & Environmental Design

Download the complete document:
<http://www.rhoss.com/download>





Rhoss has studied the **LEED**® standard and assessed the credit requirements, comparing them to its product range features and identifying which can meet the **LEED**® credit requirements and how.

Rhoss participates in the **LEED**® building certification protocol. The international system is based on the whole building's life cycle from design and construction, to management and maintenance.

Rhoss: certified quality.

- Rhoss participates in Eurovent certification programs for chillers, heat pumps and fan coils, according to the EN 14511 - EN 9614 - EN 1397 standards.
- Rhoss participates in the Eurovent certification program for Air handling units with the ADV range according to EN 13053 and EN1886.
- Rhoss participates in the Casa Clima program, a protocol that ensures buildings with a high level of living comfort despite reduced energy and management costs, thereby contributing significantly to protecting the environment.
- Rhoss offers solutions that promote sustainable construction in terms of energy efficiency, meeting the requirements of the most important Green-Building certifications, specifically LEED certification. In fact, these products or systems are designed with a technology that is concretely conducive to reducing HVAC system energy requirements. Rhoss solutions that excel in sustainability are easily recognisable by the Green Line mark, representing Rhoss' commitment to respecting the environment.



www.eurovent-certification.com
www.certiflash.com



www.eurovent-certification.com
www.certiflash.com

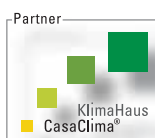

Innovation is in our DNA



The assurance of a quality product is obtained by means of thorough tests in the R&D Lab, one of the largest testing labs in Europe.

Every Rhoss unit is subjected to rigorous operating tests before being launched on the market, simulating the most extreme operating conditions.

EXP Systems is the multi-purpose ecological system designed by RHOSS to satisfy cold and hot water demands simultaneously or independently with a single unit. It is designed for use in 2, 4 and 6-pipe systems, at any time of year.

This flexibility allows it to be used in several types of construction, thereby allowing any subsequent change in the intended use.

An entire range with air and water cooled from 5 to 800 kW with TER* index up to 8.33.

The offer includes new Class A models with high ESEER efficiency with partial loads.



Polyvalent systems
the evolution of energy savings

Download the complete document:
<http://www.rhoss.com/download>

* TER Total Efficiency Ratio in total heat recovery mode AUTOMATIC 2.

** 6-pipe systems achievable with the WinPOWER EXP range.





2-pipe systems *AUTOMATIC* or *SELECT* modes

Summer "AUTOMATIC"
cooling and domestic hot water

COLD WATER HOT WATER DOMESTIC HOT WATER

Winter "SELECT"
heating and domestic hot water

HOT WATER HOT WATER DOMESTIC HOT WATER



4 or 6-pipe systems ** *AUTOMATIC* mode throughout the year



Summer cooling

COLD WATER HOT WATER

Mid-season cooling and heating

COLD WATER HOT WATER

Winter heating

COLD WATER HOT WATER

VPF solution by RHOSS: the new

Cooling systems with VPF (Variable Primary Flow), ideal for medium to large cooling capacities, are an interesting alternative to more conventional constant flow systems. In fact, the solutions designed by Rhoss offer benefits like reduced pumping unit energy consumption with consequent cost savings, as well as reliability and simplified system control.

Using these systems contributes significantly to achieving more LEED building certification credits.

Variable flow systems

The Rhoss VPF solution can be summarised as follows:

The primary circuit pump or double pump is inverter-controlled to regulate the flow and thereby reduce pumping power [$P = f(Q^3)$].

The customer provides the inverter pump/pumps to control the secondary one. In this case, Rhoss can control them and, therefore, there will be no limitations in their use.

VPF testing in the Rhoss R&D Lab, regardless of the solution, has shown that the amount of water is important to stabilise operation and reduce how often the cooling unit turns ON/OFF. A primary side external tank (TANK) is recommended, connected to the unit, with a minimum volume of 5 l/kW or less if the Tank&Pump inside the unit is used.

The probe for measuring the ΔP (information required to adjust the inverter pumps) is provided and positioned by the user in the hydraulic circuit.

Using 2-way "V2" valves for the terminals and a minimum number of 3-way "V3" valves is recommended to ensure a 20% minimum flow when the terminals are closed.



VPF solution by RHOSS

the new plant engineering frontier

Download the complete document:
<http://www.rhoss.com/download>

Download the video:
<http://www.rhoss.com/download>

Advantages of the RHOSS VPF solution:

1 A stable, functional solution for system adjustment

2 Energetically advantageous solution with real pumping energy savings

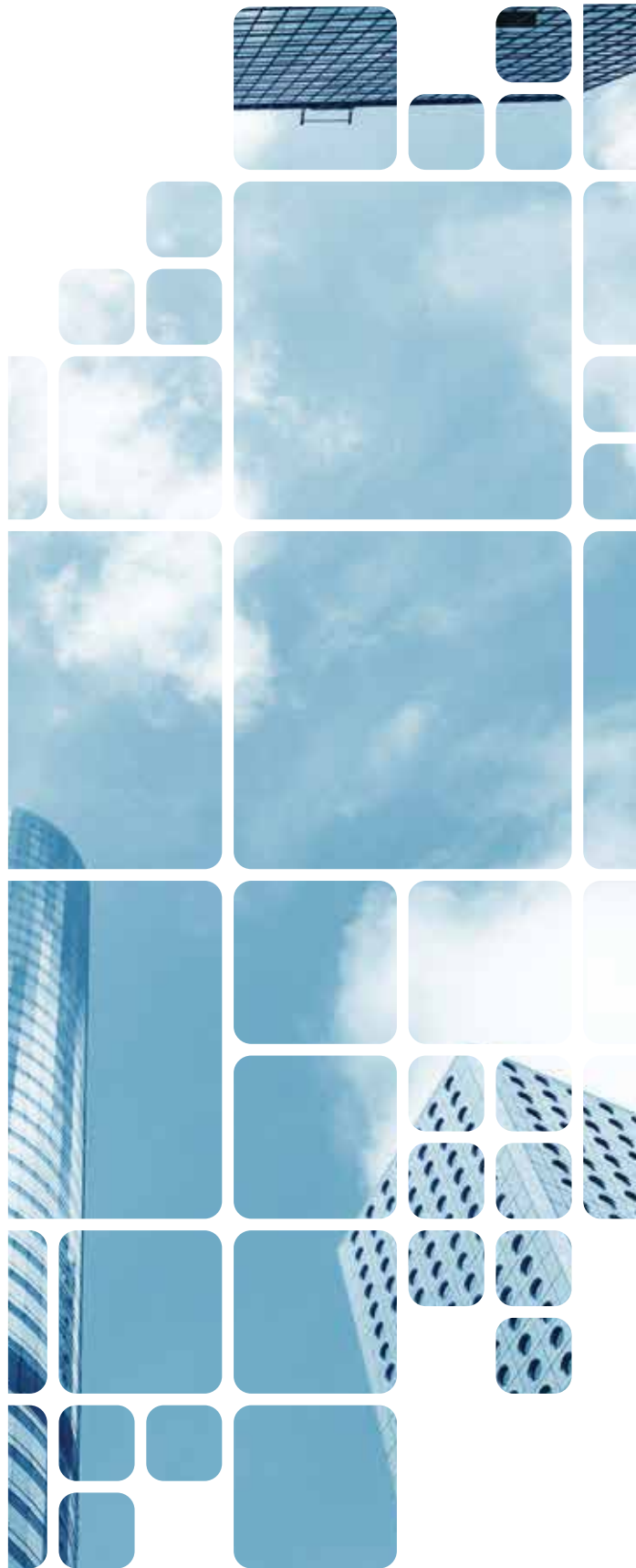

Low plant engineering breakthrough

Rhoss VPF Solution (Variable Primary Flow)

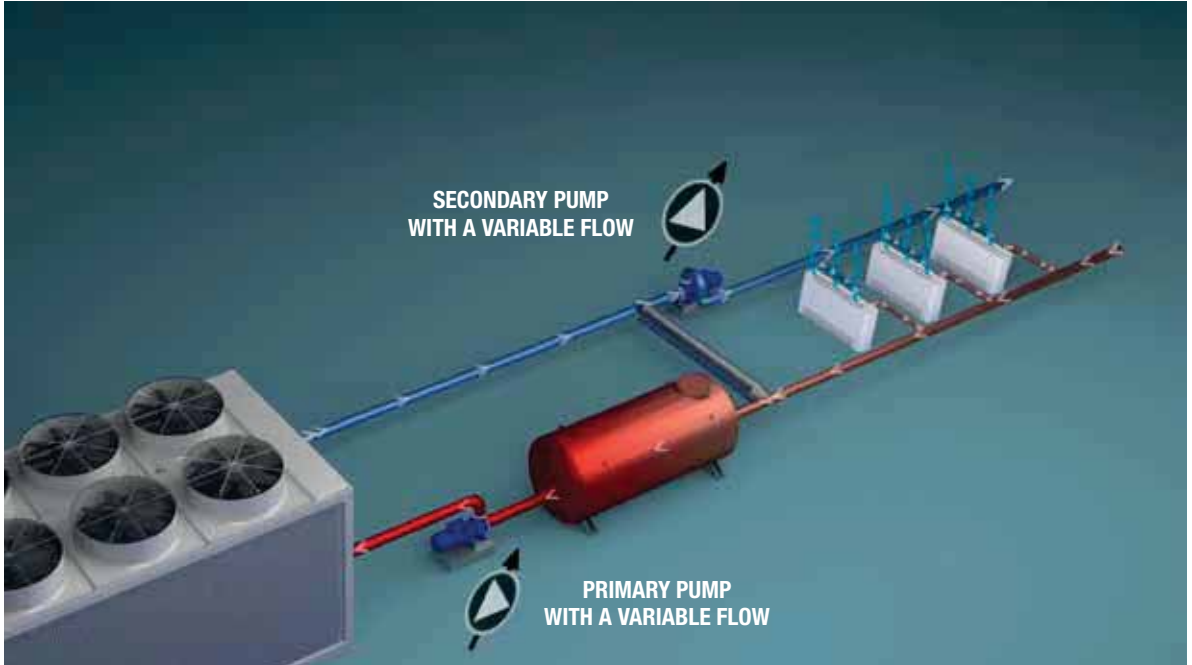

VPF RHOSS - The most efficient solution for variable flow systems

Comparison of the Rhoss VPF system and other pumping systems, when the load required changes.

Annual savings are very high in terms of energy and costs, in the Mediterranean area as well as in Central European cities, which are applicable to 100 kW cooling units installed in systems running 24/7 (hospitals, hotels, etc.).

The table indicates another important fact: the equivalent area of the photovoltaic system required to produce the electrical kW/h saved by the Rhoss system. This index shows how effective the proposed solution is.

	Annual energy consumed for pumping [kW/h]	Rhoss system savings [kW/h]	Surface area of photovoltaic system required to achieve the same savings as with the Rhoss system [m ²]
Primary constant flow and constant secondary	14.903	86%	81
Primary constant flow and variable secondary	7.472	71%	34
Conventional VPF system	5.442	60%	21
Rhoss VPF system	2.166		

* Example of comparative results for 100 kW cooling unit installed in the plant with a variable load operating 24 hours a day (hospitals, hotels, etc.) in the northern Italy and central Europe climatic area.

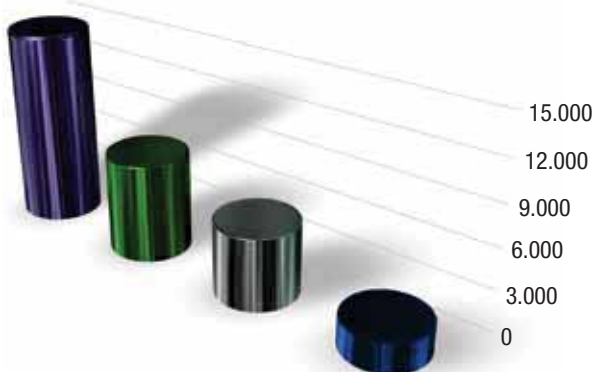

- Primary constant flow and constant secondary
- Primary constant flow and variable secondary
- Traditional VPF system
- Conventional VPF system

3 Safe solution for the chiller

4 Validated solution even with multiple chillers connected in parallel

RHOSS: worldwide solutions for energy efficiency

In commercial and residential buildings, often, the predominant part of consumption is represented by the energy required for summer and winter air conditioning and for the necessary air renewal and treatment.

The designer's role is all the more crucial when facing the energy challenges of the coming years and the research presented here is primarily an incentive to a systemic and comprehensive approach to the design of HVAC systems (Heating Ventilation and Air Conditioning).

The efficiency route

But how can the maximum possible reduction in fuel consumption and emissions, already in the design phase, be assessed?

A large building is a complex "body" consisting of a large number of elements and subsystems that interact with each other and with the external environment and that influence each other's performance. Using simplified simulation models that neglect these dynamic interactions are likely to lead to assessments that are often far from the actual energy performance.

This guide shows a few examples of the many results obtained from a major survey conducted by RHOSS in collaboration with researchers from the "**Department of Energy of the POLYTECHNIC OF TURIN**" and with the invaluable advice of Engineer Michele Vio (AiCARR past-president) for the identification of possible HVAC plant solutions aimed at achieving the best energy performance.

Compared plant solutions

8 different types of plant were compared for each building: 4 primary air, 3 all-air VAV and 1 with a ceiling radiant system. The decisive factors between the different types of systems are the RH setting in the environment via the UTA cold coil, the flow of fresh air (fixed or variable with the presence of people), the project temperature of the fan-coils and its variability during the season and the possible presence of a Free-Cooling system assisted by direct adiabatic cooling (DAC). In addition, for each plant solution, 6 different technologies have been considered for the heat recovery from the exhaust air and 8 different technologies for the generators.

Primary air or all-air?

Research **resulted in both plant choices being excellent and applicable** by the designer according to the specific requirements or constraints present.



Office building
Energy efficiency guide

Download the complete document:
<http://www.rhoss.com/download>



	AHU AIR HANDLING UNIT	GENERATORS REFRIGERANT UNITS	SYSTEM TERMINAL UNITS
			
MILAN	INDIRECT ADIABATIC RECOVERY WITH UNIDIRECTIONAL REGENERATIVE RECOVERY	WINPOWER EXP - MULTI-PURPOSE, SCROLL HERMETIC COMPRESSORS, R410A	FAN-COILS AND PRIMARY AIR HANDLING
			
LONDON	ROTARY RECOVERY WITH ENTHALPY WHEEL, HYGROSCOPIC TREATMENT	TURBOPOWER - WATER CHILLER, OIL-FREE CENTRIFUGAL COMPRESSORS, R134a/R1234ze	ALL-AIR SYSTEM - VAV
			
BARCELONA	INDIRECT ADIABATIC RECOVERY	WINPOWER EXP - MULTI-PURPOSE, SCROLL HERMETIC COMPRESSORS, R410A	FAN-COILS AND PRIMARY AIR HANDLING
			
BERLIN	CROSSED OR ROTARY FLOW STATIC RECOVERY (SENSITIVE)	TURBOPOWER - WATER CHILLER, OIL-FREE CENTRIFUGAL COMPRESSORS, R134a/R1234ze	FAN-COILS AND PRIMARY AIR HANDLING
			
DUBAI	ROTARY RECOVERY WITH ENTHALPY WHEEL HYGROSCOPIC TREATMENT, WITH UNIDIRECTIONAL REGENERATIVE RECOVERY	Z-POWER HT - TROPICALISED WATER CHILLER, SCREW SEMI-HERMETIC COMPRESSORS, R134a	FAN-COILS AND PRIMARY AIR HANDLING
			
MOSCOW	CROSSED OR ROTARY FLOW STATIC RECOVERY (SENSITIVE)	Z-POWER VFD - WATER CHILLER, SEMI-HERMETIC SCREW COMPRESSORS, R134a, INVERTER, Vi VARIABLE	ALL-AIR SYSTEM - VAV
			
PARIS	CROSSED OR ROTARY FLOW STATIC RECOVERY (SENSITIVE)	Y-PACK EXP - MULTI-PURPOSE, SCROLL HERMETIC COMPRESSORS, R410A	ALL-AIR SYSTEM - VAV DIRECT ADIABATIC COOLING

Readily available Rhoss solutions

UpToDate is the ideal tool for selecting the Rhoss product range and verify the technical data of each model. The integrated calculation engine requires the verification of feasibility of the proposed solution, the selection and technical dimensioning of the catalogue models.

A unique and fast way to always find the ideal solution for any application together with the high technology proposed by Rhoss products.

- Comprehensive instruments for choosing Rhoss products suitable for your needs.
- Fast search of Rhoss products.
- Always updated on the latest news.
- Detailed technical reports in 7 languages.
- **Chiller sorter also available on tablets and smartphones as a WEB application.**



CHILLER selection



Fan-coil and hydronic terminal selection

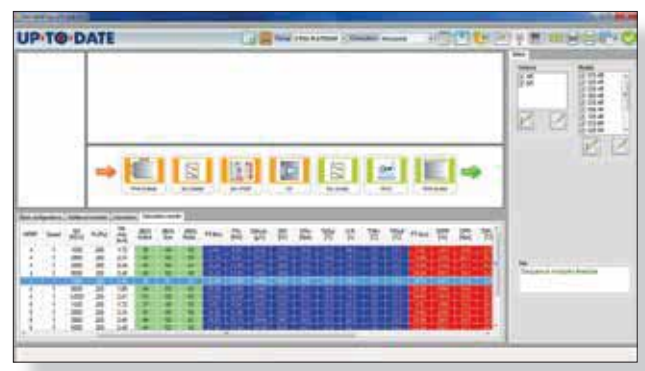
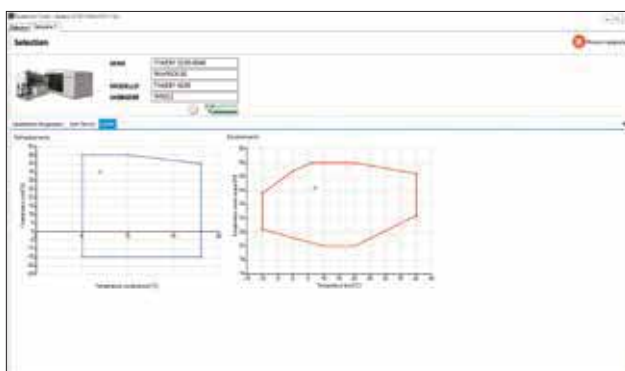
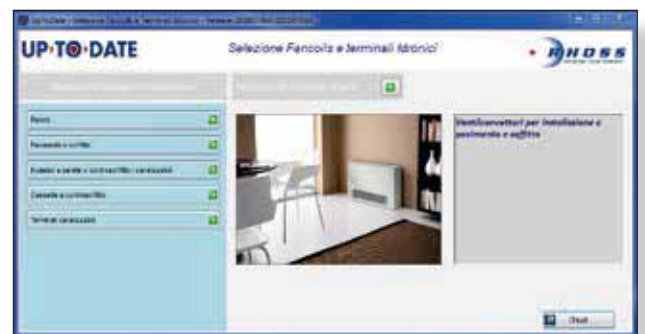



UP TO DATE

Dati Calcolati

UP TO DATE

Dati Calcolati

ID	Serv	Descr	Modello
1	Y-Power MGA	THAETY 4370-6600	THAETY 4370 DS ASP1
2	Y-Power MGA	THAETY 4370-6600	THAETY 4430 DS ASP1
3	Y-Power MGA	THAETY 4370-6600	THAETY 4440 DS ASP1
4	Y-Power MGA	THAETY 4370-6600	THAETY 5470 DS ASP1

Dettagli

Opzioni ed accessori montati a bordo

Accessori

Stampa

Salva la selezione tecnica

Clear

UP TO DATE

Dati Calcolati

Rhoss services: customised solutions for your business.

“RHOSS SERVICE” is the service par excellence that Rhoss offers its clients in order to add value to the HVAC systems

Rhoss can create service programmes and instruments that makes it possible for us to always serve you better.

What are the most significant added value aspects for a HVAC system user?

1. obtaining constant performance without problems or concerns
2. optimising equipment operation
3. minimising energy consumption
4. keeping maintenance costs low
5. eliminating operational losses
6. limiting downtimes
7. foreseeable cost management
8. compliance with local governmental and environmental regulations

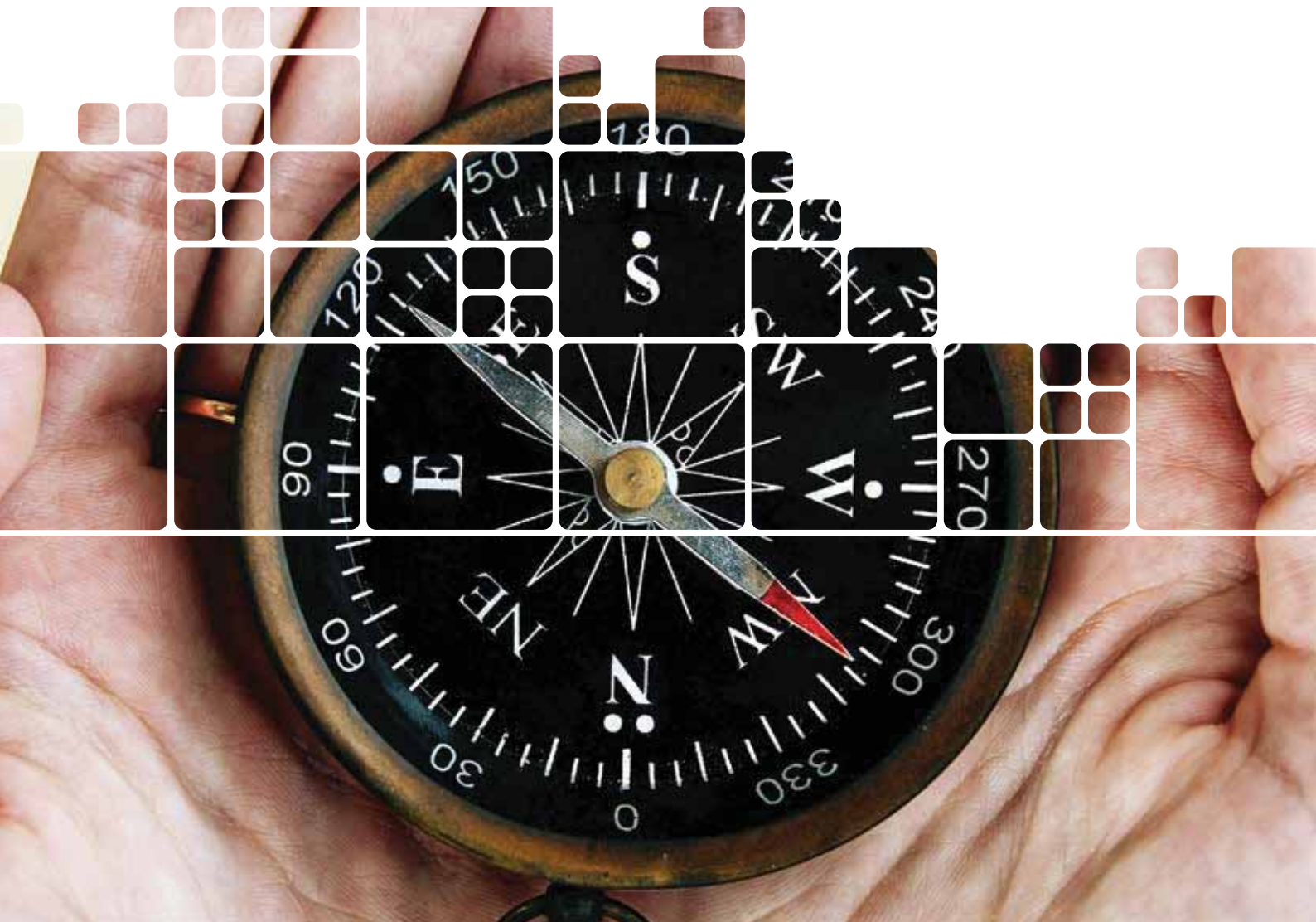



CONTRACTS - WARRANTY EXTENSION

- Extended warranties are possible for all Rhoss units, which include labour and replacement of parts that are defective during the preselected extension period.
- The scheduled maintenance contracts (Basic, Program, Full Service and Global) are designed to offer operative efficiency, extend the useful life of your system and help reduce operational costs.

MACHINE FOR TEMPORARY USE - RENTING

- Rhoss Service also means medium and long term renting of air conditioning and heating equipment.
- Rhoss Service offers a wide range of versatile machines that can satisfy all cooling needs with an "all inclusive" formula. The supply foresees a turn-key rental, quick and timely coverage of any risk connected to maintenance and operating costs.
- The main field of use are ice rinks (specific machines for working at low temperatures) and machines for the wine sector.

EXTRAORDINARY MAINTENANCE - UNIT RE-ASSEMBLY

- Increasingly often, architectural barriers and structural constraints make it impossible to replace units in areas that are difficult to reach due to weights and dimensions that do not conform with the available spaces. Rhoss Service has a team of specialised technicians who are able to perform on site disassembly and reassembly operations for the machine to be positioned.
- The Rhoss Service team can take on any request for assistance and organise the following rapidly: technical inspection, drafting of a estimate for the repairs, decisive action following approval, a warranty of 12 months on the intervention performed and the comprehensive warranty restarting for a further 6 months from when the intervention is completed.

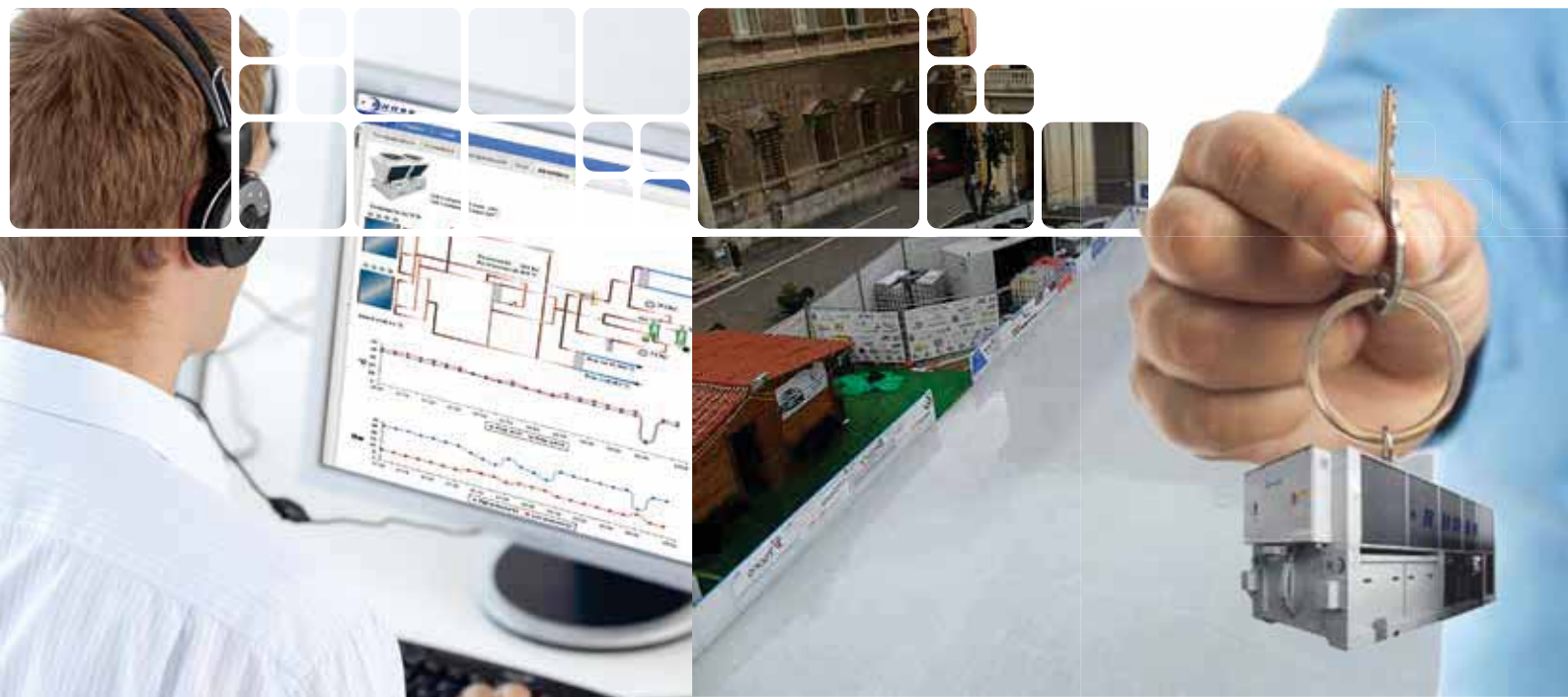

ELECTA - THAITY 105÷116

Low consumption Mini-Y - TCAEY 105÷111

Low consumption Mini-Y NF - THAEY 105÷111 NF

Low consumption Compact-I - TCAITY-THAITY 117÷128

Low consumption Compact-Y NF Plus - THAEY 115÷127 NF

Low consumption Compact-Y SM - TCAEY-THAEY 115÷130

Low consumption compact-I MD - TCAITY-THAITY 236÷260

Low consumption Compact-Y MD - TCAEY-THAEY 133÷265

Low consumption POKER - THAEY 234 H.T.

Low consumption EasyPACK - TCAEY-THAEY 269÷2146

Low consumption WinPACK HE-A - TCAEY-THAEY 2110÷4340

Low consumption WinPACK SE - TCAEY-THAEY 2110÷4340

FREECOOLING Y-Pack - TFAEY-TGAEY 4160÷4320

Low consumption WinPOWER HE-A - TCAEY 4385÷8920 / THAEY 4385÷6700

Low consumption WinPOWER SE - TCAEY 4360÷8860 / THAEY 4360÷6670

Z-Power HE - TCAVZ 2330÷2700

Z-Power HE - TCAVZ 2770÷21290

Z-Power SE - TCAVZ 1270÷1390

Z-Power SE - TCAVZ 2331÷2701

Z-Power SE - TCAVZ 2710÷21600

Z-Power VFD - TCAIZ 2520÷2900

Z-Power FREECOOLING - TFAVBZ - TFAVIZ - TFAVSZ 2420÷21100

Z-Power HP - THAVZ 2400÷2680



FullPOWER | PAGE 2

The new generation of chillers with screw compressors in R134a

TurboPOWER | PAGE 4

The new generation of chillers with Oil-free compressors in R134a



CHILLERS - HEAT PUMPS

Air cooled - Axial fans

ELECTA**THAITY 105÷116**

Cooling capacity: 3.8÷12.6 kW - Heating capacity: 6.2÷15.2 kW

INVERTER

- Operation up to **-20°C outdoor air**
- Temperature of the produced water up to **60°C**
- Plant control system integrated in the heat pump

Packaged reversible air-cooled heat pumps with axial fans.

Range with hermetic rotary DC Inverter compressors and R410A refrigerant gas.

Construction features

- Compressor: hermetic, rotary brushless DC compressor, complete with thermal protection and activated by Inverter.
- Expansion valve: electronic.
- Water side heat exchanger: Adequately insulated, stainless steel plates.
- Air side heat exchanger: finned coil with copper pipes and aluminium fins.
- Fan: axial fan rotor with DC brushless motors, equipped with internal thermal protection, protection grilles and proportional electronic device for continuous fan rotation speed regulation.
- Control: microprocessor electronic control. Enables integrated control of the heat pump and the heating system, according to the various requirements of use of the energy sources and terminal units.
- RS485 interface for serial communication with other devices (Modbus RTU protocol).
- Outdoor temperature probe for set-point compensation.
- Structure: made of galvanised and painted sheet steel, complete with condensation drain pan and unit base antifreeze heater.

Models

- THAITY: heat pump unit.

PUMP set up

- Pump unit complete with: EC circulator, manual air vent valve, safety valve and pressure gauge.

Separately supplied accessories

- 3-way valve for the production of domestic hot water, managed by regulation.
- Rubber anti-vibration mountings.
- Water filter.
- Outdoor air temperature probe with remote control option.
- Chronothermostat and user terminal (KCTR accessory).
- RHOSS supervisors for unit monitoring and remote management.



KCTR - Chronothermostat accessory to be installed inside the home to manage the temperature and operating hours, ensuring maximum comfort and minimum power consumption. It also allows you to activate the main states and modes of operation of the heat pump and set the main displays of the machine on board control.



THAITY MODEL		105	110	116
Radiant systems				
① MIN/NOM/MAX heating capacity	kW	2,0/6,5/7,1	1,7/9,9/9,9	9,4/16,0/18,5
① NOM Absorbed power	kW	1,49	2,15	3,81
① C.O.P. NOM		4,34	4,58	4,2
② MIN/NOM/MAX heating capacity	kW	2,4/4,7/5,3	5,1/6,5/9,0	6,5/10,6/12,8
② NOM Absorbed power	kW	1,72	2,41	3,8
② C.O.P. NOM		2,7	2,7	2,8
③ MIN/NOM/MAX cooling capacity	kW	2,0/5,2/5,2	4,7/7,3/9,0	3,3/16,1/16,2
③ E.E.R. NOM		4,02	3,61	3,91
Fan coil systems				
④ MIN/NOM/MAX heating capacity	kW	1,8/6,2/6,4	1,9/9,8/9,8	8,8/15,2/16,7
④ NOM Absorbed power	kW	1,98	2,83	4,47
④ C.O.P. NOM		3,12	3,44	3,4
⑤ MIN/NOM/MAX cooling capacity	kW	1,6/3,8/3,8	2,4/5,5/7,7	2,1/12,6/12,9
⑤ E.E.R. NOM		2,98	2,91	3
● E.S.E.E.R.		4	3,35	3,9
THAITY MODEL SEASONAL PERFORMANCE IN HEATING MODE				
(∅) Pdesign (EN 14825)	kW	8	11	17
(∅) SCOP (EN 14825)		3,99	4,20	4,03
(§) η_s	%	157	165	158
(§) Energy class		A++	A++	A++
⑥ Sound power	dB(A)	60	62	63
⑦ Sound pressure	dB(A)	35	37	38
⑤ Circulator available head	kPa	85	55	90
Electrical supply	V-ph-Hz	230-1-50	230-1-50	230-1-50
DIMENSIONS AND WEIGHTS				
L - Width	mm	898	850	1000
H - Height	mm	675	882	1418
P - Depth	mm	300	330	330
⑧ Weight	kg	52	77	118

Data at the following conditions:

- ① Air: 7°C D.B. - 6°C W.B. - Water: 30/35°C.
- ② Air: -7°C D.B. - Water: 30/35°C.
- ③ Air: 35° D.B. - Water: 23/18°C.
- ④ Air: 7°C D.B. - 6°C W.B. - Water: 40/45°C.
- ⑤ Air: 35° D.B. - Water: 12/7°C.
- ⑥ Sound power level in dB(A) based on measurements carried out in accordance with regulations UNI EN ISO 9614
- ⑦ In open field (Q = 2) at 5 m from the unit.
- ⑧ Weight refers to most complete set up.
- ESEER = (European seasonal EER) - Average European seasonal efficiency.
Performance according to EN 14511:2013
- (∅) In Average climatic conditions, low temperature application
- (§) Seasonal energy efficiency: low temperature application in Average climate (EU Regulations N°811/213 and N°813/2013)

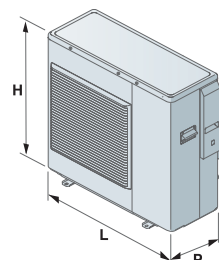

Low consumption Mini-Y TCAEY 105÷111

Cooling capacity: 5.6÷11.3 kW



• Compact and Plug&Play units

**Packaged air-cooled water chillers
with axial fans.
Range with hermetic Scroll
compressors and R410A refrigerant
gas.**

Construction features

- Compressor: hermetic, rotary scroll type, complete with thermal protection.
- Water side heat exchanger: adequately insulated stainless steel plate heat exchanger, complete with antifreeze heater and water flow differential pressure switch.
- Air side heat exchanger: with finned coil, copper pipes and aluminium fins or coil with aluminium micro-channel pipes, complete with protection grille.
- Fan: electric axial fans with external rotor, equipped with internal thermal protection and protection grilles.
- Control: microprocessor electronic control with Adaptive Function Plus logic.
- Structure: made of galvanised and painted sheet steel.

Models

- TCAEY: unit designed for cooling only.

PUMP set up

- Pump unit complete with: circulation pump, membrane expansion tank, manual air bleed valve, and safety valve.

TANK&PUMP set up

- Pump unit complete with: inertial buffer tank, circulator, membrane expansion tank, manual air bleed valve, automatic air bleed valve, safety valve.

Factory fitted accessories

- Compressor crankcase heater.
- Soft-start device (for models with 230 V power supply).
- Condensation control -10°C .
- Low pressure switch.
- Digital input for double set-point.
- 4-20 mA analogue input for shifting set-point.
- Water low set-point temperature.

Accessories supplied separately

- Outdoor air temperature probe for set-point compensation.
- Rubber anti-vibration mountings.
- -10°C condensing control.
- Water filter.
- Low pressure switch.
- Antifreeze heater on the buffer tank.
- Remote keyboard with display.
- Clock board.
- Interfaces for serial communication with other devices.
- Serial converter (RS485/USB).
- Rhoss supervisors for unit monitoring and remote management.



TCAEY MODEL		105	107	109	111
Fan coil systems					
❶ Nominal cooling capacity	kW	5,6	7,0	9,0	11,0 / 11,3
❶ Absorbed power	kW	2,07	2,72	3,4	4,20 / 4,33
❶ E.E.R.		2,7	2,57	2,65	2,62 / 2,61
● E.S.E.E.R.		3,06	2,69	3,07	3,02
★ E.S.E.E.R.+		3,50	3,07	3,50	3,42 / 3,49
Radiant systems					
❷ Cooling capacity	kW	7,6	9,4	12,4	15,4 / 15,7
❷ Absorbed power	kW	2,18	2,70	3,56	4,44 / 4,54
❷ E.E.R.		3,48	3,48	3,48	3,47 / 3,46
❸ Sound pressure	dB(A)	46	47	47	47
Scroll/step compressor	no.	1/1	1/1	1/1	1/1
Circuits	no.	1	1	1	1
Buffer tank water content	l	19	19	30	30
❶ Circulator available head	kPa	55 / 85	55 / 86	84	75
Electrical supply	V-ph-Hz	230-1-50	230-1-50 / 400-3+N-50	230-1-50 / 400-3+N-50	230-1-50 / 400-3+N-50
DIMENSIONS AND WEIGHTS					
L - Width	mm	990	990	990	990
H - PUMP height	mm	905	905	1.085	1.085
H - TANK & PUMP height	mm	905	905	1.295	1.295
P - Depth	mm	380	380	380	380
❹ Weight	kg	131	133	157	166

Data at the following conditions:

- ❶ Air: 35°C - Water: 12/7°C.
 - ❷ Air: 35°C - Water: 23/18°C.
 - ❸ In open field (Q = 2) at 5 m from the unit.
 - ❹ Weight refers to most complete set up.
 - ESEER = (European seasonal EER) - Average European seasonal efficiency.
 - ★ ESEER with Adaptive Function Plus software. ESEER+ is not Eurovent certified.
- Performance according to EN 14511:2013

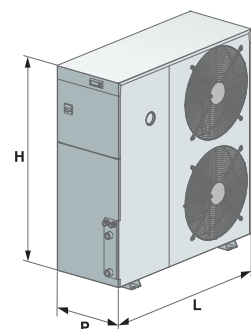

Low consumption Mini-Y NF

THAEY 105÷111 NF

Cooling capacity: 5.6÷11.3 kW - Heating capacity: 5.7÷11.8 kW



- Compact and Plug&Play units
- Working limits up to -15°C outdoor air

Packaged reversible air-cooled heat pumps with axial fans. Range with hermetic Scroll compressors and R410A refrigerant gas.

Construction features:

- Compressor: hermetic rotary scroll type, complete with thermal protection.
- Water side heat exchanger: adequately insulated stainless steel plate heat exchanger, complete with antifreeze heater and water flow differential pressure switch.
- Air side heat exchanger: featuring finned coil with copper pipes and aluminium fins with hydrophilic treatment, complete with protection grille.
- Fan: axial electric fans with external rotor, equipped with internal thermal protection and protection grilles and a proportional electronic device for continuous fan rotation speed regulation.
- Control: microprocessor electronic control with Adaptive Function Plus logic.
- Structure: made of galvanised and painted sheet steel, complete with condensation drain pan and unit base antifreeze heater.

Models

- THAEY: heat pump unit.

PUMP set up

- Pump unit complete with: circulation pump, membrane expansion tank, manual air bleed valve, and safety valve.

TANK&PUMP set up

- Pump unit complete with: inertial buffer tank, circulator, membrane expansion tank, manual air bleed valve, automatic air bleed valve, safety valve.

Factory fitted accessories

- Soft-start device (for models with 230V power supply).
- Compressor crankcase heater.
- Digital input for double set-point.
- 4-20 mA analogue input for shifting set-point.
- Water low set-point temperature.

Accessories supplied loose

- 3-way valve for the production of domestic hot water.
- Additional electric heater for heat pump, managed by regulation.
- Outdoor air temperature probe for set-point compensation.
- Rubber anti-vibration mountings.
- Water filter.
- Antifreeze on the buffer tank.
- Remote keyboard with display.
- Clock board.
- Interfaces for serial communication with other devices.
- Serial converter (RS485/USB).
- Rhoss supervisors for unit monitoring and remote management.



MODEL THAEY NF		105	107	109	111
Radiant systems					
① Heating capacity	kW	5,9	7,7	9,4	11,9/12,3
① Absorbed power	kW	1,68	2,07	2,63	3,30/3,30
① C.O.P.		3,52	3,72	3,58	3,61/3,73
② Heating capacity	kW	3,8	4,6	6,1	7,3/7,3
② Absorbed power	kW	1,65	2,13	2,69	3,35/3,38
② C.O.P.		2,30	2,16	2,27	2,18/2,16
③ Cooling capacity	kW	7,6	9	12,3	14,7/15
③ E.E.R.		3,58	3,21	3,45	3,15/3,21
Fan coil systems					
④ Heating capacity	kW	5,71	7,33	9,3	11,35/11,8
④ Absorbed power	kW	2,19	2,84	3,5	4,65/5,65
④ C.O.P.		2,61	2,58	2,66	2,44/2,09
⑤ Cooling capacity	kW	5,6	7	9	10,9/11,3
⑤ E.E.R.		2,71	2,58	2,64	2,60/2,61
● E.S.E.E.R.		3,06	2,69	3,07	3,02/3,06
★ E.S.E.E.R.+		3,5	3,07	3,5	3,42/3,49
MODEL THAEY NF SEASONAL PERFORMANCE IN HEATING MODE					
(∇) Pdesign (EN 14825)	kW	6	7	9	11
(∇) SCOP (EN 14825)		3,2	3,31	3,21	3,31
(§) η_s	%	125	130	125	129
(§) Energy class		A+	A+	A+	A+
⑥ Sound pressure	dB(A)	46	47	47	47
Scroll/step compressor	no.	42370	42370	42370	42370
Buffer tank water content	l	19	19	30	30
⑤ Circulator available head	kPa	55	55	85	75
Electrical supply	V-ph-Hz	230-1-50	230-1-50 / 400-3+N-50	230-1-50 / 400-3+N-50	230-1-50 / 400-3+N-50
DIMENSIONS AND WEIGHTS					
L - Width	mm	990	990	990	990
H - PUMP height	mm	905	905	1085	1085
H - TANK&PUMP height	mm	905	905	1295	1295
P - Depth	mm	380	380	380	380
⑦ Weight	kg	141	143	167	176

Data at the following conditions:

- ① Air: 7°C D.B. - 6°C W.B. - Water: 30/35°C.
- ② Air: -7°C D.B. - Water: 30/35°C.
- ③ Air: 35°C - Water: 23/18°C.
- ④ Air: 7°C D.B. - 6°C W.B. - Water: 40/45°C.
- ⑤ Air: 35° D.B. - Water: 12/7°C.
- ⑥ In open field ($Q = 2$) at 5 m from the unit.
- ⑦ Weight refers to most complete set up.
- ESEER = (European seasonal EER) - Average European seasonal efficiency.
- ★ ESEER with Adaptive Function Plus software. ESEER+ is not Eurovent certified.

Performance according to EN 14511:2013.

(∇) In Average climatic conditions, low temperature application

(§) Seasonal energy efficiency: low temperature application in Average climate (EU Regulations N°811/2013 and N°813/2013)

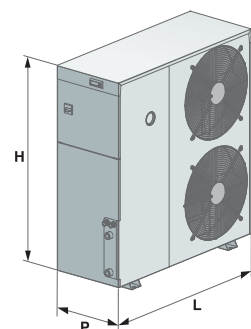

Low consumption Compact-I

TCAITY-THAITY 117÷128

Cooling capacity: 16.4÷27.6 kW - Heating capacity: 17.7÷28.5 kW

INVERTER



- Operation up to **-20°C outdoor air.**
- Hot water production up to **60°C**
- Excellent energy efficiency values
- Built-in **MASTER/SLAVE** management
- Inertial buffer tank



Packaged reversible air-cooled heat pumps and water chillers with axial fans.

Range with hermetic scroll DC Inverter compressors and R410A refrigerant gas.

Construction features

- Compressor: scroll type, rotary, hermetic with Inverter actuation, complete with thermal protection and casing heater.
- Water side heat exchanger: adequately insulated stainless steel plate heat exchanger, complete with antifreeze heater and water flow differential pressure switch.
- Air side heat exchanger: featuring finned coil with copper pipes and aluminium fins for TCAITY with hydrophilic treatment for THAITY, complete with protection grille.
- Fan: electric axial fans with external rotor, equipped with internal thermal protection, accident protection grilles and proportional electronic device for continuous fan rotation speed regulation.
- Control: microprocessor electronic control with Adaptive Function Plus logic.
- Structure: made of galvanised and painted steel plate, complete with condensation drain pan and unit base antifreeze heater for THAITY.
- The unit is also complete with:
 - outdoor air temperature probe for set-point compensation;
 - electronic expansion valve;
 - display of cooling circuit high and low pressure;
 - Master/Slave control up to 4 units in parallel;
 - clock board.

Version

- T - High efficiency

Models

TCAITY: unit intended for cooling only.
THAITY: heat pump unit.

PUMP set up

- Pump unit complete with: EC circulator with 3 speed selector or continuous speed regulation or electric pump, membrane expansion tank, manual air vent valve, safety valve and pressure gauge.

TANK&PUMP set up

- Pump unit complete with: inertial buffer tank, circulator, membrane expansion tank, manual air bleed valve, safety valve.

Factory fitted accessories

- Forced Download. Compressor partialisation or switch-off to limit the consumed current and power (digital input).
- -15°C condensation control with fans with EC motor.
- Silenced set up.
- Antifreeze heater on the buffer tank.
- Circulator/electric pump antifreeze heater.
- Copper/pre-painted aluminium or copper/copper coils.
- Digital input for double set-point.
- 4-20 mA analogue input for shifting set-point.

Accessories supplied separately

- 3-way valve for the production of domestic hot water, managed by regulation.
- Additional electric heater for heat pump, managed by regulation.
- Remotely controllable outdoor air temperature probe for set-point compensation
- Water filter.
- Rubber anti-vibration mountings.
- Remote keypad with display.
- Interfaces for serial communication with other devices.
- RS485/USB serial converter.
- Rhoss supervisors for unit monitoring and remote management.



TCAITY-THAITY MODEL		117	124	128
Radiant systems				
① MIN/NOM/MAX heating capacity	kW	7,2/18,8/19,8	10,4/25,0/27,4	11,0/29,1/31,1
① NOM Absorbed power	kW	4,59	6,09	7,09
① C.O.P. NOM		4,1	4,1	4,1
② MIN/NOM/MAX heating capacity	kW	4,2/12,3/13,8	8,1/18,1/23,1	8,1/22,9/24,8
② NOM Absorbed power	kW	4,11	6,63	7,26
② C.O.P. NOM		2,99	2,73	3,15
③ TCAITY MIN/NOM/MAX cooling capacity	kW	11,4/20,6/21,7	15,1/28,4/30,2	16,3/32,6/33,9
③ E.E.R. TCAITY NOM		4,11	4,08	4,1
Fan coil systems				
④ MIN/NOM/MAX heating capacity	kW	6,6/17,7/18,8	9,7/24,3/26,7	10,4/28,5/30,6
④ NOM Absorbed power	kW	5,33	7,45	8,68
④ C.O.P. NOM		3,32	3,26	3,28
⑤ TCAITY MIN/NOM/MAX cooling capacity	kW	8,7/16,4/17,3	12,6/24,3/25,9	13,4/27,6/28,7
⑤ E.E.R. TCAITY NOM		3,14	2,98	3,12
● E.S.E.E.R. TCAITY		5,25	4,85	4,79
★ E.S.E.E.R.+		5,99	5,47	5,37
THAITY MODEL SEASONAL PERFORMANCE IN HEATING MODE				
(∅) Pdesign (EN 14825)	kW	19	28	35
(∅) SCOP (EN 14825)		4,17	3,54	3,86
(§) η_s	%	164	139	151
(§) Energy class		A++	A+	A++
⑥ Sound pressure	dB(A)	46	48	49
⑥ Silenced set up sound pressure	dB(A)	44	46	47
⑤ Available head pressure of PO circulator	kPa	89	89	76
Buffer tank water content	l	110	110	110
Electrical supply	V-ph-Hz	400-3+N-50	400-3+N-50	400-3+N-50
DIMENSIONS AND WEIGHTS		117	124	128
L - PUMP width	mm	1522	1522	1522
L - TANK&PUMP width	mm	1625	1625	1625
H - PUMP height	mm	1280	1280	1280
H - TANK&PUMP height	mm	1590	1590	1590
P - PUMP Depth	mm	600	600	600
P - TANK&PUMP Depth	mm	600	600	600
⑧ PUMP Weight	kg	245	255	265
⑧ TANK&PUMP Weight	kg	431	441	451

Data at the following conditions:

- ① Air: 7°C D.B. - 6°C W.B. - Water: 30/35°C.
- ② Air: -7°C D.B. - Water: 30/35°C.
- ③ Air: 35° D.B. - Water: 23/18°C.
- ④ Air: 7°C D.B. - 6°C W.B. - Water: 40/45°C.
- ⑤ Air: 35° D.B. - Water: 12/7°C.
- ⑥ In open field (Q = 2) at 5 m from the unit.
- ⑧ Weight refers to most complete set up.
- ESEER = (European seasonal EER) - Average European seasonal efficiency.
- ★ ESEER with Adaptive Function Plus software. ESEER+ is not Eurovent certified.

Performance according to EN 14511:2013 PO/PIO set up.

- (∅) In Average climatic conditions, low temperature application
- (§) Seasonal energy efficiency: low temperature application in Average climate (EU Regulations N°811/213 and N°813/2013)

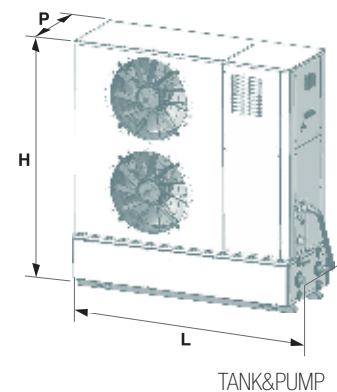

Low consumption Compact-Y NF Plus

THAETY 115÷127 NF

Cooling capacity: 15.5÷26.6 kW - Heating capacity: 16.6÷30.4 kW



- Operation up to **-15°C outdoor air**
- Temperature of the produced water up to **60°C**
- **Plug&Play unit with built-in hydraulic module**
- **Included evaporation/condensation control**

Packaged reversible air-cooled heat pumps with axial fans. Range with hermetic Scroll compressors and R410A refrigerant gas.

Construction features

- Compressor: hermetic, rotary Scroll compressor, complete with thermal protection and crankcase electric heater for mod. 127.
- Water side heat exchanger: adequately insulated stainless steel braze-welded plate heat exchanger, complete with antifreeze heater and water flow differential pressure switch.
- Air side heat exchanger: featuring finned coil with copper pipes and aluminium fins with hydrophilic treatment, complete with protection grille.
- Fan: axial electric fans with external rotor, equipped with internal thermal protection and protection grilles and a proportional electronic device for continuous fan rotation speed regulation.
- Control: microprocessor electronic control with Adaptive Function Plus logic.
- Structure: made of galvanised and painted sheet steel, complete with condensation drain pan and unit base antifreeze heater.

Version

- T - High efficiency/temperature version.

Models

- THAETY: heat pump unit.

PUMP set up

- Pump unit complete with: circulation pump, membrane expansion tank, manual air bleed valve, and safety valve.

TANK&PUMP set up

- Pump unit complete with: inertial buffer tank, circulator, membrane expansion tank, manual air bleed valve, automatic air bleed valve, safety valve.

Factory fitted accessories

- Soft-start device.
- Silenced set up.
- Antifreeze heater on the buffer tank.
- Compressor crankcase heater (mod. 115÷124).
- Digital input for double set-point.
- 4-20 mA analogue input for shifting set-point.
- Water low set-point temperature.

Separately supplied accessories

- 3-way valve for the production of domestic hot water, managed by regulation.
- Additional electric heater for heat pump, managed by regulation.
- Outdoor air temperature probe for set-point compensation.
- Rubber anti-vibration mountings.
- Water filter.
- Remote keyboard with display.
- Clock board.
- Interfaces for serial communication with other devices.
- RS485/USB serial converter.
- Rhoss supervisors for unit monitoring and remote management.



MODEL THAETY NF		115	117	122	124	127
Radiant systems						
① Heating capacity	kW	18	19	24,8	27,8	32,3
① Absorbed power	kW	4,33	4,53	5,9	6,59	7,58
① C.O.P.		4,16	4,19	4,20	4,22	4,26
② Heating capacity	kW	11,7	12	15,7	17,9	20,8
② C.O.P.		2,77	2,77	2,80	2,77	2,84
③ Cooling capacity	kW	23,3	27,1	34,6	37,8	40,4
③ Absorbed power (set up with P1 electric pump)	kW	6	6,9	8,87	9,64	10,4
③ E.E.R. (set up with P1 electric pump)		3,89	3,93	3,89	3,93	3,88
Fan coil systems						
④ Heating capacity	kW	16,6	17,7	23,4	25,9	30,4
④ Absorbed power	kW	5,72	6,32	8,18	9,08	10,03
④ C.O.P.		2,90	2,80	2,86	2,85	3,03
⑤ Cooling capacity	kW	15,5	17,6	22,5	23,9	26,6
⑤ Absorbed power	kW	5,81	6,62	8,14	9,45	10,11
⑤ E.E.R.		2,67	2,66	2,75	2,53	2,63
● E.S.E.E.R.		3,15	3,11	3,44	3,09	3,18
★ E.S.E.E.R.+		3,49	3,42	3,82	3,41	3,5
MODEL THAETY NF SEASONAL PERFORMANCE IN HEATING MODE						
(v) Pdesign (EN 14825)	kW	18	18	24	27	32
(v) SCOP (EN 14825)		3,63	3,74	3,72	3,74	3,68
(S) η_s	%	142	147	146	147	144
(S) Energy class		A+	A+	A+	A+	A+
⑥ Sound pressure	dB(A)	50	50	52	52	53
⑥ Silenced set up sound pressure	dB(A)	46	46	49	49	50
Scroll/step compressor	no.	1/1	1/1	1/1	1/1	1/1
Buffer tank water content	l	35	35	45	45	45
⑤ PO circulator nominal available head/electric pump P1	kPa	75/147	64/136	66/131	69/130	63/116
Electrical supply	V-ph-Hz	400-3+N-50	400-3+N-50	400-3+N-50	400-3+N-50	400-3+N-50
Circulator absorbed power (PO-ASPO set up)	kW	0,45	0,45	0,45	0,45	0,45
Electric pump absorbed power (P1-ASP1 set up)	kW	0,57	0,57	0,57	0,57	0,73
DIMENSIONS AND WEIGHTS						
L - PUMP width	mm	1230	1230	1230	1230	1535
L - TANK&PUMP width	mm	1522	1522	1522	1522	1822
H - Height	mm	1090	1090	1280	1280	1510
P - Depth	mm	580	580	600	600	695
⑦ Weight	kg	215	225	278	288	320

Data at the following conditions:

- ① Air: 7°C D.B. - 6°C W.B. - Water: 30/35°C.
- ② Air: -7°C D.B. - Water: 30/35°C.
- ③ Air: 35° D.B. - Water: 23/18°C.
- ④ Air: 7°C D.B. - 6°C W.B. - Water: 40/45°C.
- ⑤ Air: 35° D.B. - Water: 12/7°C.
- ⑥ In open field (Q = 2) at 5 m from the unit.
- ⑦ Weight refers to most complete set up.
- ESEER = (European seasonal EER) - Average European seasonal efficiency.
- ★ ESEER with Adaptive Function Plus software. ESEER+ is not Eurovent certified.

Performance according to EN 14511:2013. Set up with circulator.

(v) In Average climatic conditions, low temperature application

(S) Seasonal energy efficiency: low temperature application in Average climate (EU Regulations N°811/213 and N°813/2013)

Note:

- With circulator (PO/ASPO set up) the units are not suitable for radiant cooling operation.
- Permissible heat exchanger thermal gradient $\Delta T = 4 \div 8^\circ\text{C}$.

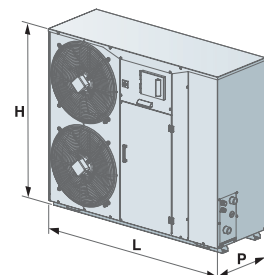

Low consumption Compact-Y SM

TCAEY-THAEY 115÷130

Cooling capacity: 15.7÷29.5 kW - Heating capacity: 16.5÷34 kW



- **ESEER with Adaptive Function Plus up to 3.8**

Packaged reversible air-cooled heat pumps and water chillers and axial fans.

Range with hermetic Scroll compressors and R410A refrigerant gas.

Construction features

- Compressor: hermetic, rotary Scroll compressor, complete with thermal protection and casing heater for mod. 127÷130.
- Water side heat exchanger: adequately insulated stainless steel plate heat exchanger, complete with antifreeze heater and water flow differential pressure switch.
- Finned coil air side heat exchanger with copper pipes and aluminium fins, complete with protection grilles.
- Fan: electric axial fans with external rotor, equipped with internal thermal protection and protection grilles.
- Control: microprocessor electronic control with Adaptive Function Plus logic.
- Structure: made of galvanised and painted sheet steel, complete with condensation drain pan.

Models

- TCAEY: unit designed for cooling only.
- THAEY: heat pump unit.

PUMP set up

- Pump unit complete with: circulation pump, membrane expansion tank, manual air bleed valve, and safety valve.

TANK&PUMP set-up

- Pump unit complete with: inertial buffer tank, circulator or electric circulation pump, membrane expansion tank, manual air bleed valve, automatic air bleed valve, safety valve, and pressure gauge.

Factory fitted accessories

- Soft-start device.
- Silenced version.
- Condensation control -10°C .
- Antifreeze heater on the buffer tank.
- Compressor crankcase heater (mod. 115÷124).
- Unit base antifreeze electric heater for operation in heat pump mode at low outdoor air temperatures.
- Digital input for double set-point.
- 4-20 mA analogue input for shifting set-point.
- Water low set-point temperature.
- Copper/pre-painted aluminium or copper/copper coils.

Separately supplied accessories

- Rubber anti-vibration mounts.
- -10°C condensing control.
- Water filter.
- 3-way valve for the production of domestic hot water.
- Outdoor air temperature probe for set-point compensation.
- Additional electrical resistance for heat pump, managed by regulation.
- Remote keypad with display.
- Clock board.
- Interfaces for serial communication with other devices.
- RS485/USB serial converter.
- Rhoss supervisors for unit monitoring and remote management.



TCAEY-THAEY MODEL		115	117	122	124	127	130	
Fan coil systems								
❶	TCAEY cooling capacity	kW	15,7	17,7	23,1	24,7	27,3	29,5
❶	TCAEY absorbed power	kW	5,69	6,63	8,25	9,32	10,54	12,04
❶	E.E.R. TCAEY		2,76	2,67	2,8	2,65	2,59	2,45
●	E.S.E.E.R. TCAEY		3,05	3,03	3,33	2,98	3,07	2,81
★	E.S.E.E.R.+		3,49	3,42	3,82	3,41	3,5	3,2
❷	Heating capacity	kW	16,5	17,5	23,5	25,7	30,3	34
❷	Absorbed power	kW	5,64	6,23	7,94	9,05	10,16	11,25
❷	C.O.P.		2,92	2,82	2,96	2,84	2,98	3,02
Radiant systems								
❸	TCAEY cooling capacity	kW	21,3	24,1	31,2	33,3	37	39,5
❸	E.E.R. TCAEY		3,49	3,33	3,5	3,32	3,29	3,01
❹	Heating capacity	kW	16,7	17,9	24	26,4	30,9	34,5
❹	C.O.P.		3,67	3,62	3,75	3,68	3,75	3,77
MODEL THAEY SEASONAL PERFORMANCE IN HEATING MODE								
(∅)	Pdesign (EN 14825)	kW	17	18	24	27	32	36
(∅)	SCOP (EN 14825)		3,14	3,13	3,21	3,17	3,26	3,20
(§)	ηs	%	123	122	125	124	128	125
(§)	Energy class		A	A	A+	A+	A+	A+
❺	Sound pressure	dB(A)	50	50	52	52	53	53
❺	Silenced set up sound pressure	dB(A)	46	46	49	49	50	50
	Scroll/step compressor	no.	1/1	1/1	1/1	1/1	1/1	1/1
	Circuits	no.	1	1	1	1	1	1
	Buffer tank water content	l	35	35	45	45	45	45
❶	Circulator nominal available head/standard electric pump	kPa	74/147	63/130	64/131	66/125	61/117	57/110
	Electrical supply	V-ph-Hz	400-3+N-50	400-3+N-50	400-3+N-50	400-3+N-50	400-3+N-50	400-3+N-50
DIMENSIONS AND WEIGHTS			115	117	122	124	127	130
L	PUMP width	mm	1230	1230	1230	1230	1535	1535
W	TANK & PUMP width	mm	1522	1522	1522	1522	1822	1822
H	Height	mm	1090	1090	1280	1280	1510	1510
P	Depth	mm	580	580	600	600	695	695
❻	TCAEY weight	kg	210	220	270	280	310	370
❻	THAEY weight	kg	215	225	278	288	320	380

Data at the following conditions:

- ❶ Air: 35°C - Water: 12/7°C.
- ❷ Air: 7°C D.B. - 6°C W.B. - Water: 40/45°C.
- ❸ Air: 35° D.B. - Water: 23/18°C.
- ❹ Air: 7°C D.B. - 6°C W.B. - Water: 30/35°C.
- ❺ In open field (Q = 2) at 5 m from the unit.
- ❻ Weight refers to most complete set up.
- ESEER = (European seasonal EER) - Average European seasonal efficiency.
- ★ ESEER with Adaptive Function Plus software. ESEER+ is not Eurovent certified.
Performance according to EN 14511:2013 Set up with electric pump.
- (∅) In Average climatic conditions, low temperature application
- (§) Seasonal energy efficiency: low temperature application in Average climate (EU Regulations N°811/2013 and N°813/2013)

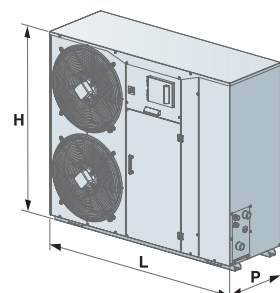

Low consumption compact-I MD

TCAITY-THAITY 236÷260

Cooling capacity: 34.3÷58.3 kW - Heating capacity: 39.9÷68.9 kW



- Operation up to -15°C outdoor air
- Hot water production up to 60°C
- Plug&Play unit with built-in hydraulic module
- Optional EC fans and inverter-based circulation pump
- Polyvalent for systems with 2 pipes + DHW (with optional RC100)
- Built-in MASTER/SLAVE management

Packaged reversible air-cooled heat pumps and water chillers and axial fans.

Range with scroll hermetic compressors DC Inverter and R410A refrigerant gas.

Construction features

- Compressor: scroll type, rotary, hermetic with Inverter actuation, complete with thermal protection and casing heater.
- Water side heat exchanger: adequately insulated stainless steel plate heat exchanger, complete with antifreeze heater and water flow differential pressure switch.
- Finned coil air side heat exchanger with copper pipes and aluminium fins, complete with protection grilles.
- Fan: electric axial fans with external rotor, equipped with internal thermal protection, accident protection grilles and proportional electronic device for continuous fan rotation speed regulation.
- Control: microprocessor electronic control with Adaptive Function Plus logic.
- Structure: made of galvanised and painted steel plate
- The unit is also complete with:
 - outdoor air temperature probe for set-point compensation;
 - display of cooling circuit high and low pressure;
 - electronic expansion valve;
 - Master/Slave control up to 4 units in parallel;
 - clock board.

Version

T - High efficiency.

Models

TCAITY: unit designed for cooling only.
THAITY: heat pump unit.

PUMP set-up

- Pump unit with single or double electric pump, including an automatic pump in standby, complete with expansion tank, air vent valves, safety valve and water side pressure gauge. The pumps are available in low or high pressure versions, and with INVERTER operation.

TANK&PUMP set-up

- Pump unit with inertial buffer tank and single or double electric pump, one in automatic in standby, complete with expansion tank, air vent valves, safety valve and water side pressure gauge. The pumps are available in low or high pressure versions, and with INVERTER operation

Factory fitted accessories

- Pre-painted copper/aluminium coils with hydrophilic or copper/copper treatment.
- Desuperheater.
- 100% Heat recovery unit
- 3-way diverter valve for the production of domestic hot water, managed by regulation.
- -15°C condensing control with fans with EC motor.
- Base antifreeze heater
- Buffer tank and electric pump antifreeze heater
- Forced Download. Compressor partialisation or switch-off to limit the consumed current and power (digital input).
- Refrigerant leak detector
- Digital input for double set-point.
- 4-20 mA analogue input for shifting set-point.
- Energy parameters measuring device.
- Silenced set up.
- Refrigerant circuit high and low pressure gauges.

Separately supplied accessories

- 3-way valve for the production of domestic hot water, managed by regulation.
- Remotely controllable outdoor air temperature probe for set-point compensation.
- Additional electrical resistance for heat pump, managed by regulation.
- Rubber anti-vibration mounts.
- Water filter.
- Thermostat with display.
- Remote keypad with display.
- Interfaces for serial communication with other devices.
- RS485/USB serial converter.
- Rhoss supervisors for unit monitoring and remote management.



TCAITY-THAITY MODEL		236	245	250	260
Radiant systems					
① MIN/NOM/MAX heating capacity	kW	9,7/39,3/40,5	12/51,3/53	13,9/54,7/56,4	16,3/70,3/72,6
① NOM Absorbed power	kW	10,4	13,3	14,1	18,3
① C.O.P. NOM		3,77	3,85	3,89	3,84
② MIN/NOM/MAX heating capacity	kW	8,3/28,6/29,2	10,9/38,6/39,4	11,4/39/39,7	14,9/53/54,1
② NOM Absorbed power	kW	11,7	15,1	14,9	20,7
② C.O.P. NOM		2,45	2,56	2,61	2,56
③ MIN/NOM/MAX cooling capacity	kW	13,6/41,7/42,8	18,4/56/57,5	20/61,1/62,8	24,3/75,8/78
③ E.E.R. NOM		3,30	3,61	3,75	3,7
Fan coil systems					
④ MIN/NOM/MAX heating capacity	kW	8,9/39,9/41,2	10,4/50,5/52,3	13/56,5/58,2	14,1/68,9/71,3
④ NOM Absorbed power	kW	12,4	15,3	17,5	21,5
④ C.O.P. NOM		3,22	3,3	3,23	3,2
⑤ MIN/NOM/MAX cooling capacity	kW	11/34,3/35,2	14,7/45,7/46,9	16/50/51,3	18,2/58,3/59,9
⑤ E.E.R. NOM		2,56	2,96	2,96	2,71
● E.S.E.E.R.		4,61	4,19	4,23	4,48
★ E.S.E.E.R.+		5,07	4,69	5	4,93
THAITY MODEL SEASONAL PERFORMANCE IN HEATING MODE					
(∇) Pdesign (EN 14825)	kW	33	44	45	60
(∇) SCOP (EN 14825)		4,24	4,07	4,36	4,25
(§) η_s	%	166	160	172	167
(§) Energy class		A++	A++	A++	A++
⑥ Sound pressure	dB(A)	54	56	56	57
⑥ Silenced set up sound pressure	dB(A)	51	53	53	54
Scroll compressor/inverter	no.	1+1	1+1	1+1	1+1
Circuits	no.	1	1	1	1
Buffer tank water content (TANK&PUMP)	l	80	150	150	150
① Available head: standard nominal pump head	kPa	129	101	114	111
Electrical supply	V-ph-Hz	400-3+N-50	400-3+N-50	400-3+N-50	400-3+N-50
DIMENSIONS AND WEIGHTS		236	245	250	260
L - Width	mm	1660	2660	2660	2660
H - Height	mm	1570	1570	1570	1570
P - Depth	mm	1000	1000	1000	1000
⑧ TCAITY weight	kg	497	697	712	740
⑧ THAITY weight	kg	507	717	732	760

Data at the following conditions:

- ① Air: 7°C D.B. - 6°C W.B. - Water: 30/35°C.
- ② Air: -7°C D.B. - Water: 30/35°C.
- ③ Air: 35° D.B. - Water: 23/18°C.
- ④ Air: 7°C D.B. - 6°C W.B. - Water: 40/45°C.
- ⑤ Air: 35° D.B. - Water: 12/7°C.
- ⑥ In open field (Q = 2) at 5 m from the unit.
- ⑧ Weight refers to most complete set up.
- ESEER = (European seasonal EER) - Average European seasonal efficiency.
- ★ ESEER with Adaptive Function Plus software. ESEER+ is not Eurovent certified.

Performance according to EN 14511:2013

(∇) In Average climatic conditions, low temperature application

(§) Seasonal energy efficiency: low temperature application in Average climate (EU Regulations N°811/213 and N°813/2013)

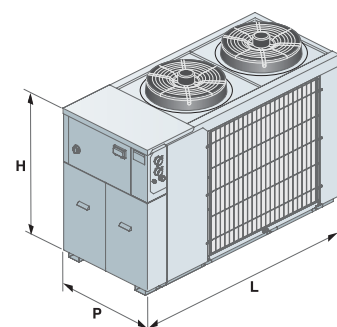

Low consumption Compact-Y MD

TCAEY-THAEY 133÷265

Cooling capacity: 33.8÷63.7 kW - Heating capacity: 39.4÷68.3 kW



- 3 capacity steps (mod. 245÷265)
- ESEER with Adaptive Function Plus up to 5
- Version HT65 for water production 65°C (°)

Packaged reversible air-cooled heat pumps and water chillers and axial fans.

Range with hermetic Scroll compressors and R410A refrigerant gas.

Construction features

- Compressor: hermetic, rotary Scroll compressor, complete with thermal protection and casing heater. 3 capacity steps with high efficiency at partial loads for models 245-265.
- Water side heat exchanger: adequately insulated stainless steel plate heat exchanger, complete with antifreeze heater and water flow differential pressure switch.
- Finned coil air side heat exchanger with copper pipes and aluminium fins, complete with protection grilles.
- Fan: electric axial fan with external rotor, equipped with internal thermal protection, protection grilles and for models 245÷265 a proportional electronic device for continuous fan speed regulation.
- Control: microprocessor electronic control with Adaptive Function Plus logic.
- Structure: made of galvanised and painted sheet steel.

Models

- TCAEY: unit designed for cooling only.
- THAEY: heat pump unit.

Factory fitted accessories

- PUMP with single or double electric pump (mod. 245÷265) including an automatic pump in standby, complete with expansion tank, air bleed valves, safety valve and water side pressure gauge. The electric pumps are available in the low or high pressure head versions.
- TANK&PUMP with inertial storage tank and single or double electric pump (mod. 245÷265) including an automatic pump in standby, complete with expansion tank, air bleed valves, safety valve and water side pressure gauge. The electric pumps are available in the low or high pressure head versions.
- Soft-start device.
- Silenced version.
- Desuperheater 15%.
- Heat recovery unit 100%.
- Refrigerant circuit high and low pressure gauges (mod. 245÷265).
- Antifreeze electric heater for buffer tank and pumps (mod. 245÷265).
- Digital input for double set-point.
- 4-20 mA analogue input for shifting set-point.
- Water low set-point temperature.
- Copper/pre-painted aluminium or copper/copper coils.

Accessories supplied loose

- 3-way valve for the production of domestic hot water, managed by regulation (mod. 133).
- Outdoor air temperature probe for set-point compensation.
- Additional electric heater for heat pump, managed by regulation.
- Rubber anti-vibration mountings.
- Water filter.
- Remote keyboard with display.
- Clock board.
- Interfaces for serial communication with other devices.
- Serial converter (RS485/USB).
- Rhoss supervisors for unit monitoring and remote management.



TCAEY-THAEY MODEL		133	233	238	245	250	260	265	
❶	TCAEY cooling capacity	kW	33,8	32,3	38,5	44	51	63,7	
❶	TCAEY absorbed power	kW	13,47	12,47	13,05	17,67	19,92	24,31	
❶	E.E.R. TCAEY		2,51	2,59	2,95	2,49	2,56	2,62	
●	E.S.E.E.R. TCAEY		2,78	2,87	3,54	3,78	4,22	4,03	
★	E.S.E.E.R.+		3,19	4,11	4,12	4,38	4,98	4,72	
❷	Heating capacity	kW	39,4	37,8	42,1	48,1	56,2	68,3	
❷	Absorbed power	kW	13,58	12,54	13,19	16,82	18,97	23,71	
❷	C.O.P.		2,9	3,01	3,19	2,86	2,96	2,88	
MODEL THAEY SEASONAL PERFORMANCE IN HEATING MODE									
(∇)	Pdesign (EN 14825)	kW	38	36	41	49	56	62	70
(∇)	SCOP (EN 14825)		3,03	3,72	3,72	3,61	3,59	3,57	3,67
(§)	ηs	%	118	146	146	142	140	140	144
(§)	Energy class		A	A+	A+	A+	A+	A+	A+
❸	Sound pressure	dB(A)	54	54	54	56	56	57	57
❸	Silenced set up sound pressure	dB(A)	51	51	51	53	53	54	54
	Scroll/step compressor	no.	1/1	2/2	2/2	2/3	2/3	2/3	
	Circuits	no.	1	1	1	1	1	1	
	Buffer tank water content (TANK&PUMP)	l	80	80	150	150	150	150	
❶	Available nominal head pressure - standard electric pump	kPa	102	106	87	113	103	88	75
	Electrical supply	V-ph-Hz	400-3+N-50	400-3+N-50	400-3+N-50	400-3+N-50	400-3+N-50	400-3+N-50	
DIMENSIONS AND WEIGHTS			133	233	238	245	250	260	265
	L - Width	mm	1660	1660	2260	2260	2260	2260	2260
	H - Height	mm	1570	1570	1570	1570	1570	1570	1570
	P - Depth	mm	1000	1000	1000	1000	1000	1000	1000
❹	TCAEY weight	kg	450	465	625	725	750	775	820
❹	THAEY weight	kg	460	475	645	745	770	795	840

Data at the following conditions:

- ❶ Air: 35°C - Water: 12/7°C.
 - ❷ Air: 7°C D.B. - 6°C W.B. - Water: 40/45°C.
 - ❸ In open field (Q = 2) at 5 m from the unit.
 - ❹ Weight refers to most complete set up.
 - ESEER = (European seasonal EER) - Average European seasonal efficiency.
 - ★ ESEER with Adaptive Function Plus software. ESEER+ is not Eurovent certified.
- Performance according to EN 14511:2013
- (∇) In Average climatic conditions, low temperature application
 - (§) Seasonal energy efficiency: low temperature application in Average climate (EU Regulations N°811/2013 and N°813/2013)

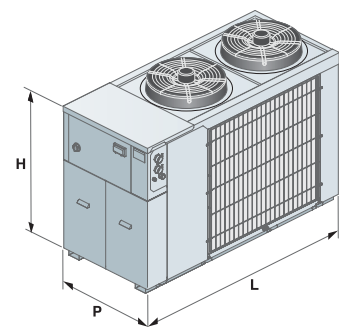

Low consumption POKER THAETY 234 H.T.

Cooling capacity: 28.8÷115.2 kW - Heating capacity: 33.8÷135.2 kW



- **Modular range: up to 4 units may be combined**
- **Total system redundancy with several modules installed**
- **Cascade management including DHW with several modules installed**
- **Hot water production from -20°C to 40°C outdoor air**
- **Temperature of the produced water up to 60°C**

Modular reversible heat pumps for high temperature water production, air cooled with axial fans. Range with hermetic Scroll compressors and R410A refrigerant gas.

Construction features

- Compressors: hermetic scroll type rotary compressors with steam injection, thermal protection and casing heater.
- Water side heat exchanger: adequately insulated stainless steel plate heat exchanger, complete with antifreeze heater and water flow differential pressure switch.
- Air side heat exchanger: finned coil heat exchanger, with copper pipes and aluminium fins with hydrophilic treatment.
- Fan: helical type electric fan with external rotor and permanent magnet motor (EC brushless) for electronic speed control, equipped with internal thermal protection and accident protection grilles.
- Control: microprocessor electronic control with Adaptive Function Plus logic.
- Structure: suitably sound-proofed, galvanised and painted steel plate, complete with antifreeze heater on the condensate drain pan.
- The unit is also complete with:
 - outdoor air temperature probe for set-point compensation;
 - display of cooling circuit high and low pressure;
 - clock board.

Version

T - High efficiency/temperature version.

Set up

- PUMP P1 - Unit complete with: circulation electric pump and manual air bleed valve.
- PUMP P1 V3V - Unit complete with: circulation electric pump, manual air bleed valve, 3-way diverter valve for the production of domestic hot water.
- PUMP P1 DS - Unit complete with: circulation electric pump to the main heat exchanger, manual air bleed valve and desuperheater complete with antifreeze heater.

MANDATORY loose supplied kits

- Remote keyboard with back-lit LCD display, which can be wall-mounted or installed on the machine.
- Side damping panels.

MANDATORY loose supplied kits

- in case of several modules installed in parallel
- Connection hoses between modules.
 - Panels and telephone cables for module connection.

Factory fitted accessories

Forced Download. Compressor partialisation or switch-off to limit the consumed current and power (digital input). When several modules are connected in parallel, a KCSC accessory must be purchased in order to enable this signal.

- Set up with increased head pressure pump.
- Soft-Start Device.
- Unit with pre-painted copper/aluminium or copper/copper condensation coils.
- Flow switch and hot wire heaters protecting heat pump and piping down to -20°C outdoor air.
- Silenced set up (ear muff to compressors).
- Cooling circuit high and low pressure gauges.
- Digital input for double set-point.
- 4-20 mA analogue input for shifting set-point.

Separately supplied accessories

- Digital input and output concentrator (KCSC).
- Rubber anti-vibration mountings.
- Water filter.
- Right-hand connection kit.
- 3-way diverter valve to manage the production of domestic hot water complete with protective casing and hoses for machine connection. For downstream installation of the machine unit. Not compatible with PUMP V3V set up.
- Additional electrical resistance for heat pump, managed by regulation.
- Interfaces for serial communication with other devices.
- RS485/USB serial converter.
- Rhoss supervisors for unit monitoring and remote management.



THAETY H.T. MODEL		234			
Fan coil systems		1 module	2 modules	3 modules	4 modules
① Heating capacity	kW	33,8	67,6	101,4	135,2
① Absorbed power	kW	9,85	19,71	29,56	39,42
① C.O.P.		3,43	3,43	3,43	3,43
② Heating capacity	kW	23,49	46,98	70,47	93,96
② Absorbed power	kW	9,83	19,66	29,48	39,31
② C.O.P.		2,39	2,39	2,39	2,39
③ Cooling capacity	kW	28,8	57,6	86,4	115,2
③ E.E.R.		2,93	2,93	2,93	2,93
● E.S.E.E.R.		4,02	4,17	4,32	4,4
★ E.S.E.E.R.+		4,5	4,71	4,86	4,97
Radiant systems		1 module	2 modules	3 modules	4 modules
④ Heating capacity	kW	33,9	67,88	101,82	135,76
④ Absorbed power	kW	8,11	16,24	24,36	32,48
④ C.O.P.		4,18	4,18	4,18	4,18
⑤ Cooling capacity	kW	39,2	78,4	117,6	156,8
⑤ Absorbed power	kW	10,18	20,36	30,55	40,73
⑤ E.E.R.		3,85	3,85	3,85	3,85
THAETY H.T. MODEL SEASONAL PERFORMANCE IN HEATING MODE		1 module	2 modules	3 modules	4 modules
(∇) Pdesign (EN 14825)	kW	32	65	98	131
(∇) SCOP (EN 14825)		3,94	4,00	4,07	4,12
(§) η_s	%	155	157	160	165
(§) Energy class		A++	A++	-	-
⑥ Sound pressure	dB(A)	43	46	47	48
⑥ Silenced set up sound pressure	dB(A)	41	44	45	46
Scroll/step compressor	no.	42402	42464	42527	42590
⑧ Electric pump nominal available head pressure	kPa	137	137	137	137
Electrical supply	V-ph-Hz	400-3-50	400-3-50	400-3-50	400-3-50
DIMENSIONS AND WEIGHTS		1 module	2 modules	3 modules	4 modules
L - Width	mm	1297	2541	3785	5029
H - Height	mm	2152	2152	2152	2152
P - Depth	mm	1224	1224	1224	1224
⑦ Weight	kg	510 (concerning a single module)			

Data at the following conditions:

- ① Air: 7°C D.B. - 6°C W.B. - Water: 40/45°C.
- ② Air: -7°C D.B. - Water: 40/45°C.
- ③ Air: 35° D.B. - Water: 12/7°C.
- ④ Air: 7°C D.B. - 6°C W.B. - Water: 30/35°C.
- ⑤ Air: 35° D.B. - Water: 23/18°C.
- ⑥ In open field (Q = 2) at 10 m from the unit.
- ⑦ Weight refers to P1 DS set up.
- ESEER = (European seasonal EER) - Average European seasonal efficiency.
- ★ ESEER with Adaptive Function Plus software. ESEER+ is not Eurovent certified.

Performance according to EN 14511:2013

(∇) In Average climatic conditions, low temperature application

(§) Seasonal energy efficiency: low temperature application in Average climate (EU Regulations N°811/213 and N°813/2013)

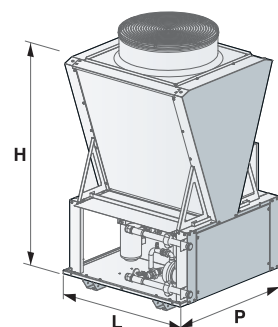

Low consumption EasyPACK

TCAEY-THAEY 269÷2146

Cooling capacity: 63.7 ÷ 144.4 kW - Heating capacity: 70.3 ÷ 151.7 kW

new



- Class A chillers and heat pumps with ESEER up to 4.31
- Complete and flexible range of accessories and setups
- Polyvalent for systems with 2 pipes + DHW (with optional RC100)
- Built-in MASTER/SLAVE management
- HT65 version for 65°C water production (°)
- Twin-circuit chiller version (°)



TCAEY 289 with coil protection metal filters

Packaged reversible air-cooled heat pumps and water chillers and axial fans. Range with hermetic Scroll compressors and R410A refrigerant.

Construction features

- Compressor: scroll type, rotary, hermetic complete with thermal protection and casing heater.
- 3 capacity steps with high efficiency at partial loads.
Water side heat exchanger: with stainless steel plates, complete with closed cell polyurethane foam rubber insulation and water flow differential pressure switch.
- Air side heat exchanger: featuring finned coil with copper pipes and aluminium fins
- Fan: external rotor axial type electric fans with internal thermal protection, accident protection grilles.
- Control: microprocessor electronic control with Adaptive Function Plus logic.
- Structure: load bearing structure made of galvanised sheet steel and painted with polyester powders.
- The unit is also complete with:
 - fan and compressor circuit breaker switches;
 - display of cooling circuit high and low pressure;
 - Master/Slave control up to 4 units in parallel;
 - clock board.

Versions

- B - Standard version (TCAEBY).
- T - High efficiency version with a larger condensing section (TCAEY-THAEY).
- S - Silenced version complete with soundproofed compressor compartment, lower fan speed and larger coil surface (TCAESY-THAESY).
- Q - Supersilenced version complete with soundproofed compressor technical compartment, super-low fan speed and larger coil surface (TCAEQY-THAEQY).

Models

- TCAEBY: standard unit intended for cooling only.
- TCAEY: high efficiency unit designed for cooling only.
- TCAESY: silenced unit designed for cooling only.
- TCAEQY: super-silenced unit designed for cooling only.
- THAEY: heat pump unit.
- THAESY: silenced heat pump unit.
- THAEQY: super-silenced heat pump unit.

Factory fitted accessories

- Shell and tube evaporator.
- PUMP with single or double electric pump, including an automatic pump in standby. The pumps are available in the low or high head versions.
- TANK&PUMP with 230 to 440 litre integrated buffer tank (depending on models) and single or double electric pump, complete with expansion tank, air vent valves, safety valve, and water side pressure gauge.
- VPF management.
- Desuperheater.
- 100% Heat recovery unit.
- Electronic expansion valve.
- -10°C condensing control (as per standard in S-Q versions).
- -15°C condensing control with fans with EC motor.
- Condensing control with over-pressure fans (B-T version only).
- Power factor correction capacitors ($\cos\phi > 0.94$).
- Forced limit of power consumption.
- Forced noise limit.
- Energy parameters measuring device.
- Optimised energy efficiency.
- Soft starter.
- Technical compartment soundproofing.
- Compressor soundproof enclosures.
- Cooling circuit delivery and intake valves.
- Refrigerant leak detector.
- Cooling circuit high and low pressure gauges.
- Double safety valves.
- Metal filters or coil protection nets.
- Copper/copper or copper/pre-painted aluminium coils.
- Control of min/max power supply voltage.
- Digital input for double set-point.
- 4-20 mA analogue input for shifting set-point.
- Evaporator antifreeze heater, electrical panel, buffer tank, electric pumps and heat exchangers for heat recovery if present.
- Buffer tank integrative heaters
- Low temperature water production.
- Interfaces for serial communication with other devices.
- Rubber anti-vibration mounts.

Accessories supplied loose

- Remote keyboard with display.
- Thermostat with display.
- Rhoss supervisors for unit monitoring and remote management.
- Rhoss sequencer for integrated management of several water chillers.



TCAEY MODEL		269	279	289	296	2112	2125	2146
❶	Nominal cooling capacity	kW	65,6	72,1	77,6	86,5	105,5	-
❶	E.E.R.		2,74	2,81	2,81	2,62	2,79	-
❶	Absorbed power	kW	23,94	25,66	27,62	33,02	37,81	-
TCAEY-TCAESY-TCAEQY MODEL		269	279	289	296	2112	2125	2146
❶	Nominal cooling capacity	kW	69,2	79,1	90,1	96,1	112	125,5
❶	Nominal cooling capacity	kW	67,7	76,7	87,6	92,1	108	122
❶	Nominal cooling capacity	kW	64,7	71,2	84,6	89,6	101,1	116,5
❶	E.E.R.		3,12	3,18	3,12	3,11	3,1	3,12
❶	E.E.R.		2,92	3,05	2,95	2,92	2,94	2,99
❶	E.E.R.		2,82	2,72	2,8	2,72	2,53	2,72
❶	E.S.E.E.R.		4,3	4,24	4,28	4,28	4,31	4,26
★	E.S.E.E.R.+		5	4,98	5,1	5,05	5,06	4,99
❶	Absorbed power	kW	22,18	24,87	28,88	30,9	36,13	40,22
❶	Absorbed power	kW	23,18	25,15	29,69	31,54	36,73	40,8
❶	Absorbed power	kW	22,94	26,18	30,21	32,94	39,96	42,83
THAETY-THAESY-THAEQY MODEL		269	279	289	296	2112	2125	2146
❷	Nominal heating capacity	kW	73,4	82,4	92,4	100,5	118,5	133,1
❷	Nominal heating capacity	kW	70,8	80,4	90,4	98	115	129,1
❷	Nominal heating capacity	kW	70,3	77,3	88,4	95,4	111	125,5
❷	C.O.P.		3,35	3,36	3,31	3,28	3,31	3,25
❷	C.O.P.		3,32	3,36	3,31	3,29	3,3	3,27
❷	C.O.P.		3,31	3,3	3,27	3,26	3,21	3,23
❶	Nominal cooling capacity	kW	67,2	76,7	86,6	93,6	107,5	121,5
❶	Nominal cooling capacity	kW	66,2	74,7	85,7	89,6	104,6	119
❶	Nominal cooling capacity	kW	63,7	69,7	82,7	86,6	99,1	112,1
❷	Absorbed power	kW	21,91	24,52	27,92	30,64	35,8	40,95
❷	Absorbed power	kW	21,33	23,93	27,31	29,79	34,85	39,48
❷	Absorbed power	kW	21,24	23,42	27,03	29,26	34,58	38,85
THAETY MODEL SEASONAL PERFORMANCE IN HEATING MODE								
(v)	Pdesign (EN 14825)	kW	66	74	84	91	108	121
(v)	SCOP (EN 14825)		3,99	3,97	3,91	3,9	4,03	3,90
(s)	ηs	%	157	156	153	153	158	153
(s)	Energy class		A++	-	-	-	-	-
THAESY MODEL SEASONAL PERFORMANCE IN HEATING MODE								
(v)	Pdesign (EN 14825)	kW	64	73	82	89	104	117
(v)	SCOP (EN 14825)		3,98	4,00	3,92	3,93	4,02	3,96
(s)	ηs	%	156	157	154	154	158	155
(s)	Energy class		A++	-	-	-	-	-
THAEQY MODEL SEASONAL PERFORMANCE IN HEATING MODE								
(v)	Pdesign (EN 14825)	kW	64	70	80	86	100	114
(v)	SCOP (EN 14825)		3,99	3,97	3,92	3,92	3,93	3,92
(s)	ηs	%	157	156	154	154	154	154
(s)	Energy class		A++	A++	-	-	-	-
TCAEY-THAEY MODEL		269	279	289	296	2112	2125	2146
❸	TCAEY sound pressure	dB(A)	50	50	50	50	52	-
❸	TCAEY-THAEY Sound pressure	dB(A)	50	51	51	51	53	54
❸	TCAEY-THAESY Sound pressure	dB(A)	46	47	47	47	49	50
❸	TCAEY-THAEQY Sound pressure	dB(A)	42	42	43	43	46	47
❹	TCAEY Sound power	dB(A)	82	82	82	82	84	-
❹	TCAEY-THAEY Sound power	dB(A)	82	83	83	83	85	86
❹	TCAEY-THAESY Sound power	dB(A)	78	79	79	79	81	82
❹	TCAEY-THAEQY Sound power	dB(A)	74	74	75	75	78	79
	Scroll/step compressor	no.	2/3	2/3	2/3	2/3	2/3	2/3
	Circuits	no.	1	1	1	1	1	1
	Electrical supply	V-ph-Hz	400-3+N-50	400-3+N-50	400-3+N-50	400-3+N-50	400-3+N-50	400-3+N-50
DIMENSIONS AND WEIGHTS		269	279	289	296	2112	2125	2146
	W - Width of version B	mm	2650	2650	2650	3250	-	-
	W - Width of version T - S - Q	mm	3250	3250	3250	3250	3450	3450
	H - Height of version B	mm	1700	1700	1700	1700	-	-
	H - Height of version T - S	mm	1700	1700	1700	1700	2000	2000
	H - Height of version Q	mm	1520	1520	1520	1520	2000	2000
	D - Depth of version B	mm	1210	1210	1210	1210	-	-
	D - Depth of version T - S - Q	mm	1210	1210	1210	1210	1520	1520
❺	TCAEY Weight	kg	755	760	795	800	980	-
❺	TCAEY Weight	kg	850	865	870	905	1160	1255
❺	THAETY weight	kg	915	930	935	980	1240	1355

Data at the following conditions:

- ❶ Air: 35°C - Water: 12/7°C.
- ❷ Air: 7°C, D.B. - 6°C W.B. - Water: 40/45°C.
- ❸ In open field (Q = 2) at 10 m from the unit on the coil side.
- ❹ Total sound power level in dB(A) based on measurements carried out in accordance with regulation UNI EN-ISO 9614.
- ❺ Weight referred to the unladen unit not accessorised.
- ❻ ESEER = (European seasonal EER) - Average European seasonal efficiency.
- ❼ ESEER with Adaptive Function Plus software. ESEER+ is not Eurovent certified.
- TCAEY-THAESY silenced versions
- TCAEY-THAEQY super-silenced versions.
- Performance according to EN 14511:2013
- (v) In Average climatic conditions; low temperature application
- (s) Seasonal energy efficiency: low temperature application in Average climate (EU Regulations N°811/2013 and N°813/2013)

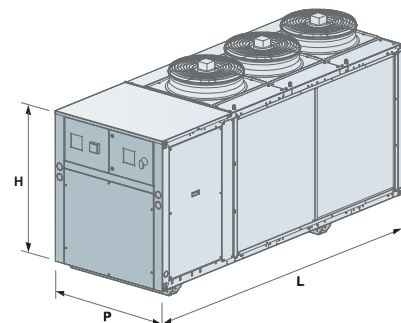



Low consumption WinPACK HE-A

TCAEY-THAEY 2110÷4340

Cooling capacity: 91,6÷345 kW - Heating capacity: 110,5÷357 kW



TCAEQY 2150
with Tank&Pump

THAEY 4270 with coil
protection grille accessory

- Chillers and heat pumps in class A
- ESEER up to 4.32
- Standard electronic expansion valve
- Polyvalent for systems with 2 pipes + DHW (with optional RC100)
- Built-in MASTER/SLAVE management

Packaged reversible air cooled water chillers and heat pumps with axial fans. Range with hermetic Scroll compressors and R410A refrigerant.

Construction features

- Compressor: scroll type, rotary, hermetic complete with thermal protection and casing heater.
- 2, 3 or 4 capacity steps with high efficiency at partial loads. Water side heat exchanger: with stainless steel plates, complete with closed cell polyurethane foam rubber insulation and water flow differential pressure switch.
- Air side heat exchanger: featuring micro-channels or finned coil with copper pipes and aluminium fins depending on the models/sizes.
- Fan: external rotor axial type electric fans with internal thermal protection, accident protection grilles.
- Control: microprocessor electronic control with Adaptive Function Plus logic.
- Structure: load bearing structure made of galvanised sheet steel and painted with polyester powders.
- The unit is also complete with:
 - fan and compressor circuit breaker switches;
 - display of cooling circuit high and low pressure;
 - electronic expansion valve;
 - Master/Slave control up to 4 units in parallel;
 - clock board.

Versions

- T - High temperature/efficiency version with larger coil surface (TCAEY-THAEY).
- Q - Supersilenced version complete with soundproofed compressor compartment, super-low fan speed and larger coil surface (TCAEQY-THAEQY).

Models

- TCAEY: high efficiency unit designed for cooling only.
- TCAEQY: supersilenced unit designed for cooling only.
- THAEY: heat pump unit.
- THAEQY: supersilenced heat pump unit.

Factory fitted accessories

- Shell and tube evaporator.
- PUMP with single or double electric pump, including an automatic pump in standby. The pumps are available in the low or high head versions.
- TANK&PUMP with built-in storage tank from 300 to 700 litres (depending on models) and single or double electric pump, complete with expansion tank, air vent valves, safety valve, and water side pressure gauge.
- VPF management.
- Desuperheater.
- 100% Heat recovery unit
- -10°C condensing control.
- -15°C condensing control with fans with EC motor (as per standard in the Q versions).
- Condensing control with over-pressure fans.
- Power factor correction capacitors ($\cos\phi > 0.94$).
- Forced limit of power consumption.
- Forced noise limit.
- Energy parameters measuring device.
- Optimised energy efficiency.
- Soft starter.
- Soundproofed compressors box or utility compartment soundproofing.
- Compressor soundproof enclosures.
- Cooling circuit delivery and intake valves.
- Refrigerant leak detector.
- Cooling circuit high and low pressure gauges.
- Double safety valves.
- Metal filters or coil protection nets.
- Micro-channel coils with E-coating treatment.
- Copper/copper or copper/pre-painted aluminium coils.
- Control of min/max power supply voltage.
- Digital input for double set-point.
- 4-20 mA analogue input for shifting set-point.
- Evaporator antifreeze heater, electrical panel, buffer tank, electric pumps and heat exchangers for heat recovery if present.
- Buffer tank integrative heaters
- Low temperature water production.
- Interfaces for serial communication with other devices.
- Anti-vibration mounts.

Accessories supplied loose

- Remote keyboard with display.
- Thermostat with display.
- Rhoss supervisors for unit monitoring and remote management.
- Rhoss sequencer for integrated management of several water chillers.





TCAEQY-TCAEQY MODEL		2110	2120	2140	2150	2170	2200	2220	4240	4270	4310	4340	
①	Nominal cooling capacity	kW	110,5	121,5	138,4	156,4	175,4	200,3	223,2	241,3	276,3	309,1	345,1
①	Nominal cooling capacity	kW	100,6	108,6	126,5	140,5	155,5	181,4	199,4	218,4	251,4	280,2	318,2
①	E.E.R.		3,13	3,1	3,13	3,11	3,1	3,11	3,1	3,1	3,1	3,1	3,1
①	E.E.R.		2,73	2,6	2,69	2,65	2,6	2,64	2,61	2,56	2,68	2,62	2,63
●	E.S.E.E.R.		4,28	4,32	4,13	4,22	4,28	4,18	4,21	4,29	4,26	4,23	4,22
★	E.S.E.E.R.+		5,02	5,09	4,96	4,98	5,04	4,89	4,95	5,1	5,06	5	5,03
①	Absorbed power	kW	35,3	39,2	44,2	50,3	56,6	64,4	72	77,8	88,8	99,7	111,3
①	Absorbed power	kW	36,8	41,8	47	53	59,8	68,7	76,4	85	93,8	106,9	121
THAEQY-THAEQY MODEL		2110	2120	2140	2150	2170	2200	2220	4240	4270	4310	4340	
②	Nominal heating capacity	kW	114,5	124,5	141,6	161,6	181,7	204,8	233,9	249,8	282,8	321	357
②	Nominal heating capacity	kW	110,5	118,5	136,5	153,6	171,6	194,7	221,8	236,7	266,7	301	341,9
②	C.O.P.		3,22	3,22	3,21	3,22	3,23	3,22	3,21	3,2	3,2	3,2	3,2
②	C.O.P.		3,28	3,29	3,27	3,26	3,26	3,23	3,26	3,12	3,11	2,95	3,08
①	Nominal cooling capacity	kW	101,6	112,6	126,5	145,4	161,4	186,3	209,3	231,3	263,3	301,1	334,1
①	Nominal cooling capacity	kW	91,6	100,6	118,6	130,6	144,5	169,5	187,4	206,5	238,4	270,3	302,3
②	Absorbed power	kW	35,6	38,7	44,1	50,2	56,3	63,6	72,9	78,1	88,4	100,3	111,6
②	Absorbed power	kW	33,7	36	41,7	47,1	52,6	60,3	68	75,9	85,8	102	111
THAEQY MODEL SEASONAL PERFORMANCE IN HEATING MODE													
(v)	Pdesign (EN 14825)	kW	96	104	118	135	150	173	201	211	242	273	302
(v)	SCOP (EN 14825)		3,53	3,52	3,75	3,49	3,77	3,39	3,57	3,64	3,62	3,64	3,63
(s)	ηs	%	138	138	147	137	148	133	140	143	142	143	142
THAEQY MODEL SEASONAL PERFORMANCE IN HEATING MODE													
(v)	Pdesign (EN 14825)	kW	91	98	113	127	141	165	190	199	227	254	288
(v)	SCOP (EN 14825)		3,62	3,61	3,84	3,59	3,88	3,53	3,65	3,56	3,54	3,37	3,52
(s)	ηs	%	142	141	151	141	152	138	143	139	139	132	138
TCAEQY-TCAEQY-THAEQY-THAEQY MODEL		2110	2120	2140	2150	2170	2200	2220	4240	4270	4310	4340	
③	TCAEQY Sound pressure	dB(A)	55	56	57	57	58	59	59	58	60	60	62
③	THAEQY sound pressure	dB(A)	53	54	55	55	56	57	57	58	60	60	62
③	TCAEQY-THAEQY Sound pressure	dB(A)	47	47	48	48	49	50	50	51	53	53	54
④	TCAEQY Sound power	dB(A)	87	88	89	89	90	91	91	90	92	92	94
④	THAEQY sound power	dB(A)	85	86	87	87	88	89	89	90	92	92	94
④	TCAEQY-THAEQY Sound power	dB(A)	79	79	80	80	81	82	82	83	85	85	86
	Scroll/step compressor	no.	2/3	2/3	2/2	2/3	2/2	2/3	2/2	4/4	4/4	4/4	4/4
	Circuits	no.	1	1	1	1	1	1	1	2	2	2	2
	Electrical supply	V-ph-Hz	400-3-50	400-3-50	400-3-50	400-3-50	400-3-50	400-3-50	400-3-50	400-3-50	400-3-50	400-3-50	400-3-50
DIMENSIONS AND WEIGHTS		2110	2120	2140	2150	2170	2200	2220	4240	4270	4310	4340	
	L - Width	mm	3600	3600	3600	3600	4550	4550	4550	4800	4800	5300	5300
	H - Height	mm	2440	2440	2440	2440	2440	2440	2440	2030	2030	2030	2030
	P - Depth	mm	1350	1350	1350	1350	1350	1350	2090	2090	2090	2090	
⑤	TCAEQY Weight	kg	1090	1100	1110	1130	1280	1300	1320	2290	2390	2520	2640
⑤	TCAEQY Weight	kg	1250	1260	1270	1290	1440	1460	1480	2420	2520	2650	2770
⑤	THAEQY weight	kg	1380	1410	1420	1500	1670	1690	1780	2470	2570	2720	2840
⑤	THAEQY weight	kg	1420	1450	1460	1540	1710	1730	1820	2600	2700	2850	2970

Data at the following conditions:

- ① Air: 35°C - Water: 12/7°C.
- ② Air: 7°C, D.B. 6°C W.B. - Water: 40/45°C.
- ③ In open field (Q = 2) at 10 m from the unit.
- ④ Total sound power level in dB(A) based on measurements carried out in accordance with regulation UNI EN-ISO 9614.
- ⑤ Weight referred to the unladen unit not accessorised.
- ESEER = (European seasonal EER) - Average European seasonal efficiency.
- ★ ESEER with Adaptive Function Plus software. ESEER+ is not Eurovent certified.
- TCAEQY-THAEQY super-silenced versions.
Performance according to EN 14511:2013
- (v) In Average climatic conditions, low temperature application
- (s) Seasonal energy efficiency: low temperature application in Average climate (EU Regulations N°811/2013 and N°813/2013)

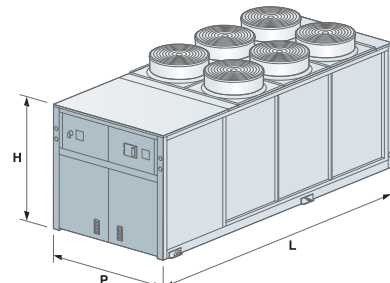
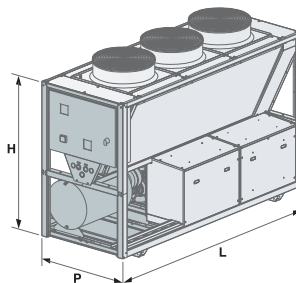

Low consumption WinPACK SE

TCAEY-THAEY 2110÷4340

Cooling capacity: 97,6÷328,6 kW - Heating capacity: 109,5÷354,6 kW



TCAESY 2200
with Tank&Pump

- High performance range with extended working limits
- Wide range of accessories
- Compact version B for replacement markets
- Polyvalent for systems with 2 pipes + DHW (with optional RC100)
- Built-in MASTER/SLAVE management

Packaged reversible air-cooled water chillers and heat pumps with axial fans.

Range with hermetic Scroll compressors and R410A refrigerant.

Construction features

- Compressor: scroll type, rotary, hermetic complete with thermal protection and casing heater.
 - 2,3 or 4 capacity steps with high efficiency at partial loads.
- Water side heat exchanger: with stainless steel plates, complete with closed cell polyurethane foam rubber insulation and water flow differential pressure switch.
- Air side heat exchanger: featuring micro-channels or finned coil with copper pipes and aluminium fins depending on the models/sizes.
 - Fan: external rotor axial type electric fans with internal thermal protection, accident protection grilles.
 - Control: microprocessor electronic control with Adaptive Function Plus logic.
 - Structure: load bearing structure made of galvanised sheet steel and painted with polyester powders.
 - The unit is also complete with:
 - fan and compressor circuit breaker switches;
 - display of cooling circuit high and low pressure;
 - Master/Slave control up to 4 units in parallel;
 - clock board.

Versions

- B - Standard version (TCAEY-THAEY).

- S - Silenced version complete with soundproofed compressor compartment, lower speed fans (TCAESY-THAESY).

Models

- TCAEY: standard unit designed for cooling only.
- TCAESY: silenced unit designed for cooling only.
- THAEY: heat pump unit.
- THAESY: silenced heat pump unit.

Factory fitted accessories

- Shell and tube evaporator.
- PUMP with single or double electric pump, including an automatic pump in standby. The pumps are available in the low or high head versions.
- TANK&PUMP with built-in storage tank from 300 to 700 litres (depending on models) and single or double electric pump, complete with expansion tank, air vent valves, safety valve, and water side pressure gauge.
- VPF management.
- Desuperheater.
- 100% Heat recovery unit
- Electronic expansion valve.
- -10°C condensing control (standard in S versions).
- -15°C condensing control with fans with EC motor.
- Condensing control with over-pressure fans.
- Power factor correction capacitors ($\cos\phi > 0.94$).
- Forced limit of power consumption.
- Forced noise limit.
- Energy parameters measuring device.
- Optimised energy efficiency.
- Soft starter.



THAEBY 4310 with coil protection grille accessory

- Soundproofed compressors box or utility compartment soundproofing.
- Compressor soundproof enclosures.
- Cooling circuit delivery and intake valves.
- Refrigerant leak detector.
- Cooling circuit high and low pressure gauges.
- Double safety valves.
- Metal filters or coil protection nets.
- Micro-channel coils with E-coating treatment.
- Copper/copper or copper/pre-painted aluminium coils.
- Control of min/max power supply voltage.
- Digital input for double set-point.
- 4-20 mA analogue input for shifting set-point.
- Evaporator antifreeze heater, electrical panel, buffer tank, electric pumps and heat exchangers for heat recovery if present.
- Buffer tank integrative heaters
- Low temperature water production.
- Interfaces for serial communication with other devices.
- Anti-vibration mounts.

Accessories supplied loose

- Remote keyboard with display.
- Thermostat with display.
- Rhoss supervisors for unit monitoring and remote management.
- Rhoss sequencer for integrated management of several water chillers.

Low consumption WinPACK SE

TCAEY-THAEY 2110÷4340

TCAEY-TCAESY MODEL		2110	2120	2140	2150	2170	2200	2220	
❶	Nominal cooling capacity	kW	106,5	114,4	127,4	147,3	165,2	182,1	212,1
❶	Nominal cooling capacity	kW	102,5	110,4	122,4	142,3	159,2	183,2	205,1
❶	E.E.R.		2,81	2,79	2,8	2,81	2,81	2,8	2,8
❶	E.E.R.		2,72	2,67	2,65	2,71	2,7	2,66	2,7
●	E.S.E.E.R.		3,91	3,94	3,96	3,85	3,93	4	3,87
★	E.S.E.E.R.+		4,62	4,63	4,66	4,52	4,61	4,75	4,57
❶	Absorbed power	kW	37,9	41	45,5	52,4	58,8	67,2	75,8
❶	Absorbed power	kW	37,7	41,3	46,2	52,5	59	68,9	76
THAEY-THAESY MODEL		2110	2120	2140	2150	2170	2200	2220	
❷	Nominal heating capacity	kW	112,6	123,7	139,7	158,8	176,9	198	229,1
❷	Nominal heating capacity	kW	109,5	121,7	135,7	155,8	173,9	195,9	226
❷	C.O.P.		3,05	3,08	3,08	3,04	3,06	3,07	3,07
❷	C.O.P.		3,1	3,13	3,1	3,13	3,1	3,09	3,13
❶	Nominal cooling capacity	kW	99,5	110,4	123,4	142,3	159,3	182,2	206,1
❶	Nominal cooling capacity	kW	97,6	106,5	117,5	136,4	152,3	175,3	199,2
❷	Absorbed power	kW	36,9	40,2	45,4	52,2	57,8	64,5	74,6
❷	Absorbed power	kW	35,3	38,9	43,8	49,8	56,1	63,4	72,2
THAEY MODEL SEASONAL PERFORMANCE IN HEATING MODE									
(∇)	Pdesign (EN 14825)	kW	95	104	119	134	149	170	200
(∇)	SCOP (EN 14825)		3,39	3,4	3,68	3,36	3,64	3,35	3,53
(§)	ηs	%	132	133	144	132	142	131	138
THAESY MODEL SEASONAL PERFORMANCE IN HEATING MODE									
(∇)	Pdesign (EN 14825)	kW	92	102	115	131	146	167	197
(∇)	SCOP (EN 14825)		3,47	3,49	3,71	3,5	3,73	3,39	3,63
(§)	ηs	%	136	137	146	137	146	133	142
TCAEY-TCAESY-THAEY-THAESY MODEL		2110	2120	2140	2150	2170	2200	2220	
❸	TCAEY sound pressure	dB(A)	55	56	56	57	58	58	59
❸	THAEY sound pressure	dB(A)	53	54	54	55	56	56	57
❸	TCAESY sound pressure	dB(A)	49	50	50	51	52	52	53
❸	THAESY sound pressure	dB(A)	49	50	50	51	52	52	53
❹	TCAEY Sound power	dB(A)	87	88	88	89	90	90	91
❹	THAEY sound power	dB(A)	85	86	86	87	88	88	89
❹	TCAESY sound power	dB(A)	81	82	82	83	84	84	85
❹	THAESY sound power	dB(A)	81	82	82	83	84	84	85
	Scroll/step compressor	no.	2/3	2/3	2/2	2/3	2/2	2/3	2/2
	Circuits	no.	1	1	1	1	1	1	1
	Electrical supply	V-ph-Hz	400-3-50	400-3-50	400-3-50	400-3-50	400-3-50	400-3-50	400-3-50
DIMENSIONS AND WEIGHTS		2110	2120	2140	2150	2170	2200	2220	
	W - TCAEY-TCAESY width	mm	2650	2650	2650	3600	3600	4550	
	W - THAEY-THAESY width	mm	2650	2650	2650	3600	3600	4550	
	H - TCAEY-TCAESY height	mm	2440	2440	2440	2440	2440	2440	
	H - THAEY-THAESY height	mm	2440	2440	2440	2440	2440	2440	
	D - TCAEY-TCAESY depth	mm	1350	1350	1350	1350	1350	1350	
	D - THAEY-THAESY depth	mm	1350	1350	1350	1350	1350	1350	
❺	TCAEY Weight	kg	990	1000	1010	1160	1180	1340	
❺	TCAESY Weight	kg	1110	1120	1130	1280	1300	1460	
❺	THAEY weight	kg	1250	1310	1320	1470	1480	1730	
❺	THAESY weight	kg	1250	1310	1320	1470	1480	1730	

Data at the following conditions:

- ❶ Air: 35°C - Water: 12/7°C.
- ❷ Air: 7°C, D.B. 6°C W.B. - Water: 40/45°C.
- ❸ In open field (Q = 2) at 10 m from the unit.
- ❹ Total sound power level in dB(A) based on measurements carried out in accordance with regulation UNI EN-ISO 9614.
- ❺ Weight referred to the unladen unit not accessorised.
- ESEER = (European seasonal EER) - Average European seasonal efficiency.
ESEER with Adaptive Function Plus software. ESEER+ is not Eurovent certified.
- TCAESY-THAESY silenced versions
Performance according to EN 14511:2013
- (∇) In Average climatic conditions, low temperature application
- (§) Seasonal energy efficiency: low temperature application in Average climate (EU Regulations N°811/213 and N°813/2013)

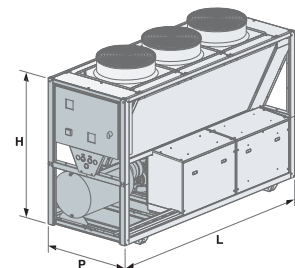

TCAEBY-TCAESY MODEL		4150	4170	4200	4220	4240	4270	4310	4340	
❶	Nominal cooling capacity	kW	146,3	166,4	189,2	213,2	229,2	256	299,9	328,7
❶	Nominal cooling capacity	kW	142,3	161,4	182,3	207,2	224,2	250	291	319,7
❶	E.E.R.		2,99	2,9	2,83	2,92	2,8	2,8	2,81	2,76
❶	E.E.R.		2,93	2,82	2,67	2,82	2,68	2,66	2,68	2,61
●	E.S.E.E.R.		4,11	4,13	4,12	4,12	4,05	4,09	3,96	3,96
★	E.S.E.E.R.+		4,85	4,87	4,87	4,85	4,8	4,84	4,7	4,69
❶	Absorbed power	kW	48,9	57,4	66,9	73	81,9	91,4	106,7	119,1
❶	Absorbed power	kW	48,6	57,2	68,3	73,5	83,7	94	108,6	122,5
THAEBY-THAESY MODEL		4150	4170	4200	4220	4240	4270	4310	4340	
❷	Nominal heating capacity	kW	152,7	172,6	197,8	225,9	249	281,3	319,3	354,6
❷	Nominal heating capacity	kW	147,7	167,6	192,8	219,9	245	278,3	315,2	345,5
❷	C.O.P.		3,09	3,14	3,04	3,04	3,03	3,01	3,01	2,98
❷	C.O.P.		3,1	3,12	3,09	3,09	3,09	3,05	3,07	3,03
❶	Nominal cooling capacity	kW	141,3	163,4	186,2	209,1	227,1	253,9	295,9	324,7
❶	Nominal cooling capacity	kW	136,4	156,4	180,3	200,2	220,2	248	286,1	313,8
❷	Absorbed power	kW	49,4	55	65,1	74,3	82,2	93,5	106,1	119
❷	Absorbed power	kW	47,6	53,7	62,4	71,2	79,3	91,2	102,7	114
THAEBY MODEL SEASONAL PERFORMANCE IN HEATING MODE										
(∅)	Pdesign (EN 14825)	kW	129	145	168	192	211	240	271	301
(∅)	SCOP (EN 14825)		3,41	3,47	3,34	3,34	3,35	3,34	3,35	3,32
(§)	ηs	%	133	136	130	130	131	130	131	130
THAESY MODEL SEASONAL PERFORMANCE IN HEATING MODE										
(∅)	Pdesign (EN 14825)	kW	125	140	164	187	207	238	267	292
(∅)	SCOP (EN 14825)		3,42	3,46	3,4	3,4	3,45	3,39	3,41	3,37
(§)	ηs	%	134	135	133	133	135	133	133	132
TCAEBY-TCAESY-THAEBY-THAESY MODEL		4150	4170	4200	4220	4240	4270	4310	4340	
❸	TCAEBY sound pressure	dB(A)	57	57	57	58	60	60	60	61
❸	THAEBY sound pressure	dB(A)	54	54	56	56	58	60	60	61
❸	TCAESY sound pressure	dB(A)	51	51	51	52	54	54	56	57
❸	THAESY sound pressure	dB(A)	50	50	52	52	54	55	56	57
❹	TCAEBY Sound power	dB(A)	89	89	89	90	92	92	92	93
❹	THAEBY sound power	dB(A)	86	86	88	88	90	92	92	93
❹	TCAESY sound power	dB(A)	83	83	83	84	86	86	88	89
❹	THAESY sound power	dB(A)	82	82	84	84	86	87	88	89
	Scroll/step compressor	no.	4/4	4/4	4/4	4/4	4/4	4/4	4/4	4/4
	Circuits	no.	2	2	2	2	2	2	2	2
	Electrical supply	V-ph-Hz	400-3-50	400-3-50	400-3-50	400-3-50	400-3-50	400-3-50	400-3-50	400-3-50
DIMENSIONS AND WEIGHTS		4150	4170	4200	4220	4240	4270	4310	4340	
W	TCAEBY-TCAESY width	mm	3600	3600	3600	4550	4550	4550	4800	4800
W	THAEBY-THAESY width	mm	3450	3450	3700	3700	4800	4800	4800	4800
H	TCAEBY-TCAESY height	mm	2440	2440	2440	2440	2440	2440	2030	2030
H	THAEBY-THAESY height	mm	2000	2000	2030	2030	2030	2030	2030	2030
D	TCAEBY-TCAESY depth	mm	1350	1350	1350	1350	1350	1350	2090	2090
D	THAEBY-THAESY depth	mm	1520	1520	2090	2090	2090	2090	2090	2090
❺	TCAEBY Weight	kg	1165	1185	1190	1335	1670	1690	2400	2410
❺	TCAESY Weight	kg	1300	1320	1325	1470	1830	1850	2440	2450
❺	THAEBY weight	kg	1450	1525	1725	1800	2375	2460	2580	2595
❺	THAESY weight	kg	1475	1550	1765	1840	2415	2500	2620	2635

Data at the following conditions:

- ❶ Air: 35°C - Water: 12/7°C.
 - ❷ Air: 7°C, D.B. 6°C W.B. - Water: 40/45°C.
 - ❸ In open field (Q = 2) at 10 m from the unit.
 - ❹ Total sound power level in dB(A) based on measurements carried out in accordance with regulation UNI EN-ISO 9614.
 - ❺ Weight referred to the unladen unit not accessorised.
 - ESEER = (European seasonal EER) - Average European seasonal efficiency.
 - ★ ESEER with Adaptive Function Plus software. ESEER+ is not Eurovent certified.
 - TCAESY-THAESY silenced versions
- Performance according to EN 14511:2013
- (∅) In Average climatic conditions, low temperature application
- (§) Seasonal energy efficiency: low temperature application in Average climate (EU Regulations N°811/2013 and N°813/2013)

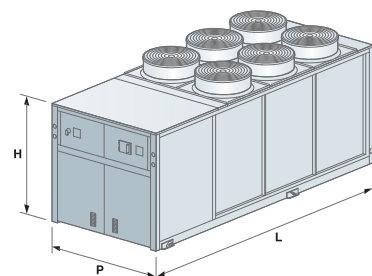

FREECOOLING Y-Pack

TFAEY-TGAEY 4160÷4320

Cooling capacity: 170÷361 kW



TFAEY 4230 with
accessory coil protection
grilles



- Availability of NO GLYCOL version
- Plug&Play range
- Software for estimate of energy saving

Air cooled water chillers in Freecooling mode (TFAEY) and Freecooling NO-GLYCOL mode (TGAEY) with axial fans. Range with hermetic Scroll compressors and R410A refrigerant.

Construction features

- Compressor: scroll type, rotary, hermetic complete with thermal protection and crankcase heater.
- 4 capacity steps with high efficiency at partial loads.
- Water side heat exchanger (evaporator): stainless steel plate exchanger, complete with closed cell polyurethane foam rubber insulation and water flow differential pressure switch (TFAEY) or flow switch (TGAEY).
- Heat exchanger (water-water) in Free-cooling NO-GLYCOL mode: stainless steel plate exchanger, complete with closed cell polyurethane foam rubber insulation and water flow differential pressure switch.
- Air side heat exchanger (condenser): featuring finned coil with copper pipes and aluminium fins.
- Fan: axial electric fans with external rotor, equipped with internal thermal protection and protection grilles and a proportional electronic device for continuous fan rotation speed regulation.
- Control: microprocessor electronic control with Adaptive Function Plus logic.
- Structure: load bearing structure made of galvanised sheet steel and painted with polyester powders.
- The unit is also complete with:
 - compressors and fans MCBs;
 - clock board;
 - 3-way modulating water side valve.

Versions

- T - High efficiency version (TFAEY-TGAEY).
- S - Silenced version complete with compressor technical compartment soundproofing and reduced speed fans (TFAESY-TGAESY).

Models

- TFAEY: high efficiency unit in Freecooling mode.
- TFAESY: silenced unit in Freecooling mode.
- TGAEY: high efficiency unit in Freecooling NO-GLYCOL mode.
- TGAESY: silenced unit in Freecooling NO-GLYCOL mode.

Factory fitted accessories

- PUMP with single or double electric pump, including an automatic pump in standby complete with safety valve. The pumps are available in the low or high pressure versions.
- Electronic expansion valve.
- Power factor correction capacitors ($\cos\phi > 0.94$).
- Soft starter.
- Cooling circuit high and low pressure gauges.
- Metal filters or coil protection grilles.
- Copper/copper or copper/pre-painted aluminium coils.
- Digital input for double set-point.
- 4-20 mA analogue input for shifting set-point.
- Evaporator antifreeze heater, electric pumps if present.
- Interfaces for serial communication with other devices.
- Anti-vibration mountings.

Separately supplied accessories

- Remote keypad with display.
- Rhoss supervisors for unit monitoring and remote management.



TFAETY-TFAESY MODEL		4160	4180	4200	4230	4260	4290	4320
FREE-COOLING OFF								
① Nominal cooling capacity	kW	178	202	224	251	286	326	361
① Nominal cooling capacity	kW	170	197	215	240	274	312	344
① E.E.R.		3,31	3,41	3,27	3,20	3,34	3,20	3,09
① E.E.R.		3,21	3,32	3,11	3,11	3,22	3,09	2,92
① Absorbed power	kW	53,8	59,3	68,4	78,5	85,6	102,0	117,0
① Absorbed power	kW	53,0	59,3	69,2	77,2	85,2	100,9	117,9
FREE-COOLING ON 100%								
② Nominal cooling capacity	kW	178	202	224	251	286	326	361
② Nominal cooling capacity	kW	170	197	215	240	274	312	344
② E.E.R.		21,3	24,4	26,9	20,5	22,8	19,5	21,5
② E.E.R.		33,0	37,8	41,4	31,7	35,2	30,0	32,9
② Absorbed power	kW	8	8	8	12	12	16	16
② Absorbed power	kW	5	5	5	7,5	7,5	10	10
② Total Free-cooling Temperature	°C	0,3	1	0,4	0,7	0,9	0,4	-0,8
② Total Free-cooling Temperature	°C	-1,3	-0,8	-1,5	-1,3	-1,1	-1,6	-3,0
TFAETY-TFAESY MODEL								
③ Sound pressure	dB(A)	60	63	63	65	65	66	66
③ Sound pressure	dB(A)	55	56	56	58	59	60	60
④ Sound power	dB(A)	89	91	91	93	93	94	94
④ Sound power	dB(A)	85	86	86	88	89	90	90
Scroll/step compressor	no.	4/4	4/4	4/4	4/4	4/4	4/4	4/4
Circuits	no.	2	2	2	2	2	2	2
Electrical supply	V-ph-Hz	400-3+N-50	400-3+N-50	400-3+N-50	400-3+N-50	400-3+N-50	400-3+N-50	400-3+N-50
DIMENSIONS AND WEIGHTS								
L - Width	mm	4.800	4.800	4.800	4.800	5.300	5.300	5.300
H - Height	mm	2.030	2.030	2.030	2.030	2.030	2.030	2.030
P - Depth	mm	2.090	2.090	2.090	2.090	2.090	2.090	2.090
⑤ TFAETY-TFAESY weight	kg	2.370	2.820	2.920	3.020	3.230	3.380	3.430
⑤ TGAETY-TGAESY weight	kg	2.470	2.970	3.070	3.170	3.280	3.430	3.480

Data at the following conditions:

- ① Air: 30°C - Water: 15/10°C - Ethylene glycol 30%.
 - ② Water: 15/10°C – Ethylene glycol 30%.
 - ③ In open field (Q = 2) at 10 m from the unit on the coil side.
 - ④ Total sound power level in dB(A) based on measurements carried out in accordance with regulation UNI EN-ISO 9614.
 - ⑤ Weight refers to the accessorised unit when empty.
- TFAESY silenced version.

EXAMPLE OF OUTPUT SOFTWARE FOR THE ESTIMATION OF ENERGY SAVING

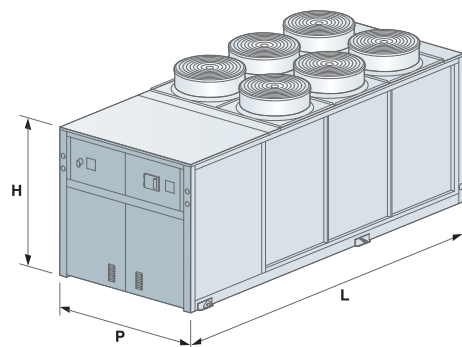
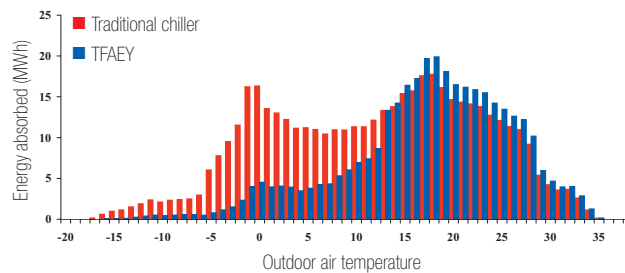

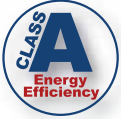

new



- Chillers in CLASS A
- Extended operating limits
- Up to 6 capacity steps with ESEER up to 4.4
- Polyvalent for systems with 2 pipes + DHW (with optional RC100)
- Built-in MASTER/SLAVE management

Low consumption WinPOWER HE-A

TCAEY 4385÷8920 / THAEY 4385÷6700

Cooling capacity: 337.3÷916.8 kW - Heating capacity: 368.8÷698.9 kW



TCAEY 6700
with BC accessory

Reversible air cooled heat pumps and water chillers with axial fans. Range with hermetic scroll compressors and R410A refrigerant.

Construction features

- Compressor: scroll type, rotary, hermetic complete with thermal protection and casing heater.
- Up to 6 capacity steps with high efficiency at partial loads.
- Water side heat exchanger: with stainless steel plates, complete with closed cell polyurethane foam rubber insulation, water flow differential pressure switch and Victaulic fittings.
- Air side heat exchanger: featuring micro-channels (TCAEY) or finned coil with copper pipes and aluminium fins (THAEY).
- Fan: external rotor axial type electric fans with internal thermal protection, accident protection grilles.
- Control: microprocessor electronic control with Adaptive Function Plus logic.
- Structure: load bearing structure made of galvanised sheet steel and painted with polyester powders.

• The unit is also complete with:

- fan and compressor circuit breaker switches;
- display of cooling circuit high and low pressure,
- electronic expansion valve.
- clock board.
- Master/Slave control up to 4 units in parallel.

Versions

- T - High efficiency version with an oversized condensing section (TCAEY - THAEY).
- Q - Super-silenced version complete with soundproofing compressor technical compartment, super-reduced speed fans and oversized condensing section (TCAEQY-THAEQY).

Models

- TCAEY: high efficiency unit designed for cooling only.
- TCAEQY: super-silenced unit designed for cooling only.
- THAEY: high efficiency heat pump unit.
- THAEQY: super-silenced heat pump unit.



TCAEQY 8920

THAETY 4460
with BFI accessory

Factory fitted accessories

- Shell and tube evaporator.
- PUMP with single or double electric pump, including an automatic pump in standby. The pumps are available in the low or high head versions.
- TANK&PUMP with 700 or 1000 litre integrated buffer tank (depending on size) and single or double electric pump, complete with expansion tank, air vent valves, safety valve and water side pressure gauge.
- VPF management.
- Desuperheater.
- 100% Heat recovery unit
- -10°C condensing control.
- -15°C condensing control with fans with EC motor (as per standard in the Q versions).
- Condensing control with over-pressure fans.
- Power factor correction capacitors ($\cos\phi > 0.94$).
- Forced limit of power consumption.
- Forced noise limit.
- Energy parameters measuring device.
- Optimised energy efficiency.
- Soft starter.
- Soundproofed compressor box or Compressor box and soundproofed cooling circuit (THAETY).
- Compressor soundproof enclosures.
- Cooling circuit delivery and intake valves.
- Refrigerant leak detector.
- Cooling circuit high and low pressure gauges.
- Double safety valves

- Metal filters (THAETY) or coil protection nets.
- Micro-channel coils with E-coating treatment (TCAEQY).
- Copper/copper or copper/pre-painted aluminium coils (THAETY).
- Control of min/max power supply voltage.
- Digital input for double set-point.
- 4-20 mA analogue input for shifting set-point.
- Evaporator antifreeze heater, electrical panel, buffer tank, electric pumps and heat exchangers for heat recovery if present.
- Low temperature water production.
- Interfaces for serial communication with other devices.
- Anti-vibration mounts.

Accessories supplied loose

- Remote keyboard with display.
- Thermostat with display.
- Rhoss supervisors for unit monitoring and remote management.
- Rhoss sequencer for integrated management of several water chillers.

Low consumption WinPOWER HE-A

TCAEY 4385÷8920 / THAEY 4385÷6700

TCAEY-TCAEQY MODEL		4385	4415	4460	5525	6570	6625
❶ Nominal cooling capacity	kW	385	414	460,8	524,5	569,5	623,1
❶ Nominal cooling capacity	kW	355,2	381,1	420,1	469,9	510,8	558,6
❶ E.E.R.		3,24	3,16	3,13	3,19	3,17	3,1
❶ E.E.R.		2,87	2,71	2,64	2,71	2,63	2,47
● E.S.E.E.R.		4,33	4,31	4,3	4,36	4,34	4,32
✳ E.S.E.E.R.+		5	4,97	4,96	5,04	5,01	4,99
❶ Absorbed power	kW	118,9	131,1	147,3	164,5	179,7	201
❶ Absorbed power	kW	123,8	140,7	159,2	173,4	194,3	226,2
TCAEY-TCAEQY MODEL		4385	4415	4460	5525	6570	6625
❸ TCAEY Sound pressure	dB(A)	62,5	63,5	64,5	64,5	64,5	64,5
❸ TCAEQY Sound pressure	dB(A)	53,5	53,5	54,5	54,5	54,5	54,5
❹ TCAEY Sound power	dB(A)	95	96	97	97	97	97
❹ TCAEQY Sound power	dB(A)	86	86	87	87	87	87
Scroll/step compressor	no.	4/4	4/4	4/4	5/5	6/6	6/6
Circuits	no.	2	2	2	2	2	2
Electrical supply	V-ph-Hz	400-3-50	400-3-50	400-3-50	400-3-50	400-3-50	400-3-50
DIMENSIONS AND WEIGHTS		4385	4415	4460	5525	6570	6625
L - Width	mm	4840	4840	4840	5940	5940	5940
H - Height	mm	2450	2450	2450	2450	2450	2450
P - Depth	mm	2260	2260	2260	2260	2260	2260
❺ TCAEY Weight	kg	2440	2460	2510	2980	3200	3210
❺ TCAEQY Weight	kg	2715	2735	2785	3300	3565	3575

TCAEY-TCAEQY MODEL		6665	6700	7760	8820	8870	8920
❶ Nominal cooling capacity	kW	665,3	695,2	758,3	819,9	870	916,8
❶ Nominal cooling capacity	kW	604,7	632,6	694,7	753,3	791,5	827,3
❶ E.E.R.		3,16	3,13	3,14	3,15	3,14	3,13
❶ E.E.R.		2,7	2,65	2,67	2,67	2,64	2,6
● E.S.E.E.R.		4,37	4,29	4,4	4,4	4,37	4,32
✳ E.S.E.E.R.+		5,04	4,99	5,09	5,09	5,05	5
❶ Absorbed power	kW	210,6	222,2	241,5	260,3	277,1	293
❶ Absorbed power	kW	224	238,8	260,2	282,2	299,9	318,2
TCAEY-TCAEQY MODEL		6665	6700	7760	8820	8870	8920
❸ TCAEY Sound pressure	dB(A)	65,5	65,5	65,5	65,5	66	67
❸ TCAEQY Sound pressure	dB(A)	55,5	56,5	57	57	58	59
❹ TCAEY Sound power	dB(A)	98	98	98	98	99	100
❹ TCAEQY Sound power	dB(A)	88	89	90	90	91	92
Scroll/step compressor	no.	6/6	6/6	7/6	8/6	8/6	8/6
Circuits	no.	2	2	2	2	2	2
Electrical supply	V-ph-Hz	400-3-50	400-3-50	400-3-50	400-3-50	400-3-50	400-3-50
DIMENSIONS AND WEIGHTS		6665	6700	7760	8820	8870	8920
L - Width	mm	7100	7100	8250	9350	9350	9350
H - Height	mm	2450	2450	2450	2450	2450	2450
P - Depth	mm	2260	2260	2260	2260	2260	2260
❺ TCAEY Weight	kg	3715	3740	4250	4650	4750	4770
❺ TCAEQY Weight	kg	4080	4105	4655	5105	5205	5225

Data at the following conditions:

- ❶ Air: 35°C - Water: 12/7°C.
- ❷ Air: 7°C, D.B. 6°C W.B.- Water: 40/45°C.
- ❸ In open field (Q = 2) at 10 m from the unit.
- ❹ Total sound power level in dB(A) based on measurements carried out in accordance with regulation UNI EN-ISO 9614.
- ❺ Weight referred to the unladen unit not accessorised.
- ESEER = (European seasonal EER) - Average European seasonal efficiency.
- ✳ ESEER with Adaptive Function Plus software. ESEER+ is not Eurovent certified.
- TCAEQY super-silenced versions.

Performance according to EN 14511:2013

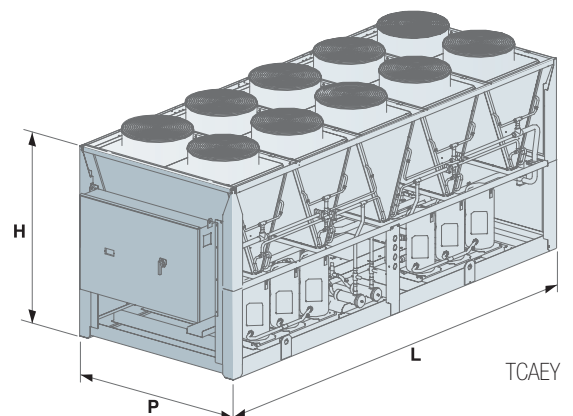

TCAEY

THAETY-THAEQY MODEL		4385	4415	4460	5525	6570	6625	6665	6700
②	Nominal heating capacity	kW	386,9	425	464,2	520,4	571,5	626,8	698,9
②	Nominal heating capacity	kW	368,8	404,9	441	493,2	535,3	598,6	661,6
②	C.O.P.		3,2	3,2	3,2	3,2	3,2	3,21	3,22
②	C.O.P.		3,24	3,22	3,22	3,2	3,21	3,25	3,23
①	Nominal cooling capacity		359,2	399	439,9	498,7	538,6	584,4	660,3
①	Nominal cooling capacity		337,3	367,2	401,1	453	483,9	520,8	601,7
①	E.E.R.		2,97	2,96	2,95	3,02	2,95	2,9	3,02
①	E.E.R.		2,66	2,55	2,49	2,6	2,47	2,29	2,51
●	E.S.E.E.R.		4,1	4,09	4,08	4,1	4,09	4,11	4,15
②	Absorbed power	kW	121	132,9	145,1	162,7	178,6	195,9	217,1
②	Absorbed power	kW	113,9	125,8	137	154,2	167,3	186,5	204,9
THAETY MODEL SEASONAL PERFORMANCE IN HEATING MODE									
(∅)	Pdesign (EN 14825)	kW	354	388	-	-	-	-	-
(∅)	SCOP (EN 14825)		3,53	3,56	-	-	-	-	-
(§)	ηs	%	138	139	-	-	-	-	-
THAEQY MODEL SEASONAL PERFORMANCE IN HEATING MODE									
(∅)	Pdesign (EN 14825)	kW	337	370	-	-	-	-	-
(∅)	SCOP (EN 14825)		3,70	3,69	-	-	-	-	-
(§)	ηs	%	145	145	-	-	-	-	-
THAETY-THAEQY MODEL			4385	4415	4460	5525	6570	6625	6700
③	THAETY sound pressure	dB(A)	62,5	63,5	64,5	64,5	64,5	64,5	65,5
③	THAEQY sound pressure	dB(A)	53,5	53,5	54,5	54,5	54,5	54,5	55,5
④	THAETY sound power	dB(A)	95	96	97	97	97	97	98
④	THAEQY sound power	dB(A)	86	86	87	87	87	87	88
	Scroll/step compressor	no.	4/4	4/4	4/4	5/5	6/6	6/6	6/6
	Circuits	no.	2	2	2	2	2	2	2
	Electrical supply	V-ph-Hz	400-3-50	400-3-50	400-3-50	400-3-50	400-3-50	400-3-50	400-3-50
DIMENSIONS AND WEIGHTS			4385	4415	4460	5525	6570	6625	6700
	L - Width	mm	4840	4840	4840	5940	5940	5940	7100
	H - Height	mm	2450	2450	2450	2450	2450	2450	2450
	P - Depth	mm	2260	2260	2260	2260	2260	2260	2260
⑤	THAETY weight	kg	3030	3200	3250	3830	4040	4070	4680
⑤	THAEQY weight	kg	3395	3565	3615	4310	4520	4550	5210

Data at the following conditions:

- ① Air: 35°C - Water: 12/7°C.
 - ② Air: 7°C, D.B. 6°C W.B. - Water: 40/45°C.
 - ③ In open field (Q = 2) at 10 m from the unit.
 - ④ Total sound power level in dB(A) based on measurements carried out in accordance with regulation UNI EN-ISO 9614.
 - ⑤ Weight referred to the unladen unit not accessorised.
 - ESEER = (European seasonal EER) - Average European seasonal efficiency.
 - ★ ESEER with Adaptive Function Plus software. ESEER+ is not Eurovent certified.
 - TCAEQY super-silenced versions.
- Performance according to EN 14511:2013
- (∅) In Average climatic conditions, low temperature application
- (§) Seasonal energy efficiency: low temperature application in Average climate (EU Regulations N°811/213 and N°813/2013)

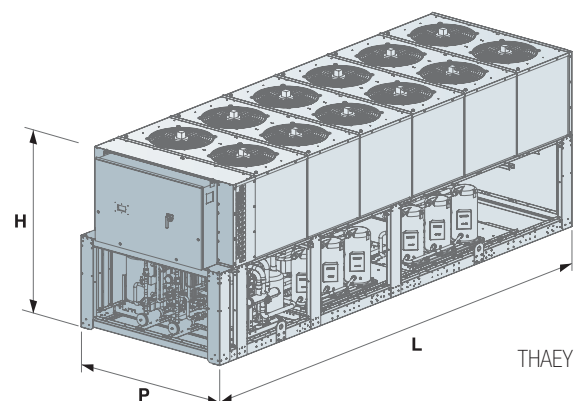

Low consumption WinPOWER SE

TCAEY 4360÷8860 / THAEY 4360÷6670

Cooling capacity: 335÷861.8 kW - Heating capacity: 358.1÷671.5 kW



new



- **Version B compact and high-performance for replacement markets**
- **Up to 6 capacity steps**
- **Simplified installation thanks to pumping units accessories**
- **Polyvalent for systems with 2 pipes + DHW (with optional RC100)**
- **Built-in MASTER/SLAVE management**



THAESY 6590
with BFI accessory

Reversible air cooled heat pumps and water chillers with axial fans. Range with hermetic scroll compressors and R410A refrigerant.

Construction features

- Compressor: scroll type, rotary, hermetic complete with thermal protection and casing heater.
- up to 6 capacity steps with high efficiency at partial loads.
- Water side heat exchanger: with stainless steel plates, complete with closed cell polyurethane foam rubber insulation, water flow differential pressure switch and Victaulic fittings.
- Air side heat exchanger: featuring micro-channels (TCAEY) or finned coil with copper pipes and aluminium fins (THAEY).
- Fan: external rotor axial type electric fans with internal thermal protection, accident protection grilles.
- Control: microprocessor electronic control with Adaptive Function Plus logic.
- Structure: load bearing structure made of galvanised sheet steel and painted with polyester powders.

- The unit is also complete with:
 - fan and compressor circuit breaker switches;
 - display of cooling circuit high and low pressure,
 - electronic expansion valve.
 - clock board.
 - Master/Slave control up to 4 units in parallel

Versions

- B - Standard version (TCAEY-THAEY).
- S - Silenced version complete with compressor technical compartment soundproofing and reduced speed fans (TCAESY - THAESY).

Models

- TCAEY: unit intended for cooling only.
- TCAESY: silenced unit designed for cooling only.
- THAEY: heat pump unit.
- THAESY: silenced heat pump unit.



TCAESY 8860

THAESY 6590
with BFI accessory

Factory fitted accessories

- Shell and tube evaporator.
- PUMP with single or double electric pump, including an automatic pump in standby. The pumps are available in the low or high head versions.
- TANK&PUMP with 700 or 1000 litre integrated buffer tank (depending on size) and single or double electric pump, complete with expansion tank, air vent valves, safety valve and water side pressure gauge.
- VPF management.
- Desuperheater.
- 100% Heat recovery unit
- -10°C condensing control (as per standard in S versions).
- -15°C condensing control with fans with EC motor.
- Condensing control with over-pressure fans.
- Power factor correction capacitors ($\cos\phi > 0.94$).
- Forced limit of power consumption.
- Forced noise limit.
- Energy parameters measuring device.
- Optimised energy efficiency.
- Soft starter.
- Soundproofed compressor box or Compressor box and soundproofed cooling circuit (THAEY).
- Compressor soundproof enclosures.
- Cooling circuit delivery and intake valves.
- Refrigerant leak detector.
- Cooling circuit high and low pressure gauges.
- Double safety valves.
- Metal filters (THAEY) or coil protection nets.

- Micro-channel coils with E-coating treatment (for TCAEY).
- Copper/copper or copper/pre-painted aluminium coils (for THAEY).
- Control of min/max power supply voltage.
- Digital input for double set-point.
- 4-20 mA analogue input for shifting set-point.
- Evaporator antifreeze heater, electrical panel, buffer tank, electric pumps and heat exchangers for heat recovery if present.
- Low temperature water production.
- Interfaces for serial communication with other devices.
- Anti-vibration mounts.

Accessories supplied loose

- Remote keyboard with display.
- Thermostat with display.
- Rhoss supervisors for unit monitoring and remote management.
- Rhoss sequencer for integrated management of several water chillers.

Low consumption WinPOWER SE

TCAEY 4360÷8860 / THAEY 4360÷6670

TCAEY-TCAESY MODEL		4360	4390	4435	5500	6540	6590
❶ Nominal cooling capacity	kW	359,8	389,6	434,6	496,3	538,9	587,9
❶ Nominal cooling capacity	kW	350,9	374,7	416,7	478,4	517,1	560,1
❶ E.E.R.		2,9	2,84	2,81	2,96	2,9	2,77
❶ E.E.R.		2,76	2,62	2,6	2,77	2,68	2,52
● E.S.E.E.R.		4,11	4,1	4,09	4,16	4,15	4,09
⊛ E.S.E.E.R.+		4,75	4,74	4,72	4,83	4,8	4,72
❶ Absorbed power	kW	124,1	137,2	154,7	167,7	185,9	212,3
❶ Absorbed power	kW	127,2	143,1	160,3	172,8	193	222,3
TCAEY-TCAESY MODEL		4360	4390	4435	5500	6540	6590
③ Sound pressure	dB(A)	62	63	64	64	64	64
③ Sound pressure	dB(A)	57	58	59	59	59	59
④ Sound power	dB(A)	94	95	96	96	96	96
④ Sound power	dB(A)	89	90	91	91	91	91
Scroll/step compressor	no.	4/4	4/4	4/4	5/5	6/6	6/6
Circuits	no.	2	2	2	2	2	2
Electrical supply	V-ph-Hz	400-3-50	400-3-50	400-3-50	400-3-50	400-3-50	400-3-50
DIMENSIONS AND WEIGHTS		4360	4390	4435	5500	6540	6590
L - Width	mm	3740	3740	3740	4840	4840	4840
H - Height	mm	2450	2450	2450	2450	2450	2450
P - Depth	mm	2260	2260	2260	2260	2260	2260
⑤ TCAEY Weight	kg	2130	2140	2200	2670	2860	2890
⑤ TCAESY Weight	kg	2360	2370	2430	2940	3165	3195

TCAEY-TCAESY MODEL		6635	6670	7730	8790	8830	8860
❶ Nominal cooling capacity	kW	637,7	666,5	732,4	784	827,1	861,8
❶ Nominal cooling capacity	kW	611,9	637,8	705,6	752,3	790,4	825,1
❶ E.E.R.		2,93	2,9	2,93	2,84	2,81	2,8
❶ E.E.R.		2,74	2,72	2,76	2,63	2,61	2,6
● E.S.E.E.R.		4,14	4,06	4,19	4,12	4,11	4,08
⊛ E.S.E.E.R.+		4,78	4,76	4,84	4,76	4,75	4,72
❶ Absorbed power	kW	217,7	229,9	250	276,1	294,4	307,8
❶ Absorbed power	kW	223,4	234,5	255,7	286,1	302,9	317,4
TCAEY-TCAESY MODEL		6635	6670	7730	8790	8830	8860
③ Sound pressure	dB(A)	64,5	64,5	64,5	64,5	65	66
③ Sound pressure	dB(A)	59,5	60	60	60	60,5	61,5
④ Sound power	dB(A)	97	97	97	97	98	99
④ Sound power	dB(A)	92	92,5	92,5	92,5	93	94
Scroll/step compressor	no.	6/6	6/6	7/6	8/6	8/6	8/6
Circuits	no.	2	2	2	2	2	2
Electrical supply	V-ph-Hz	400-3-50	400-3-50	400-3-50	400-3-50	400-3-50	400-3-50
DIMENSIONS AND WEIGHTS		6635	6670	7730	8790	8830	8860
L - Width	mm	5940	5940	7150	7150	7150	7150
H - Height	mm	2450	2450	2450	2450	2450	2450
P - Depth	mm	2260	2260	2260	2260	2260	2260
⑤ TCAEY Weight	kg	3205	3230	3870	4020	4100	4120
⑤ TCAESY Weight	kg	3510	3535	4210	4410	4490	4510

Data at the following conditions:

- ❶ Air: 35°C - Water: 12/7°C.
- ❷ Air: 7°C, D.B. 6°C W.B. - Water: 40/45°C.
- ③ In open field (Q = 2) at 10 m from the unit.
- ④ Total sound power level in dB(A) based on measurements carried out in accordance with regulation UNI EN-ISO 9614.
- ⑤ Weight referred to the unladen unit not accessorised.
- ESEER = (European seasonal EER) - Average European seasonal efficiency.
- ⊛ ESEER with Adaptive Function Plus software. ESEER+ is not Eurovent certified.

■ TCAESY - THAEY silenced versions

Performance according to EN 14511:2013

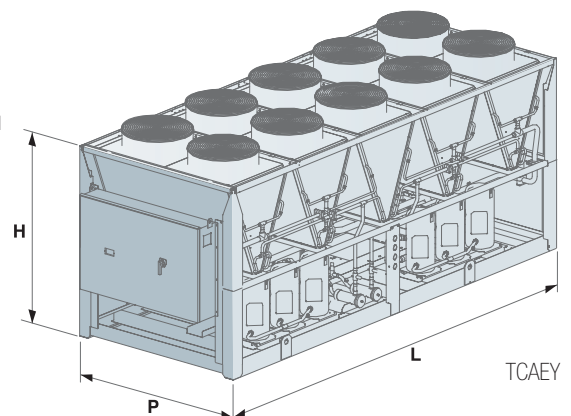

TCAEY

THAEBY-THAESY MODEL		4360	4390	4435	5500	6540	6590	6635	6670	
②	Nominal heating capacity	kW	374,2	398,4	437,4	487,7	530	592,1	638,3	671,5
②	Nominal heating capacity	kW	358,1	386,3	424,3	473,6	518,9	575	616,1	648,4
②	C.O.P.		3,01	2,94	3,03	2,98	2,93	2,97	3,04	3
②	C.O.P.		3,01	2,94	3,02	2,99	2,95	2,96	3,03	3
①	Nominal cooling capacity	kW	346,9	368,7	410,7	465,4	509,1	553,2	600,9	631,7
①	Nominal cooling capacity	kW	335	355,9	389,9	444,6	486,4	532,4	576,1	603,9
①	E.E.R.		2,8	2,67	2,64	2,78	2,71	2,6	2,76	2,75
①	E.E.R.		2,64	2,49	2,42	2,55	2,51	2,41	2,6	2,58
●	E.S.E.E.R.		4	3,9	3,89	3,94	3,93	3,88	3,96	3,95
②	Absorbed power	kW	124,4	135,6	144,4	163,7	180,9	199,4	210	223,9
②	Absorbed power	kW	119	131,4	140,5	158,4	175,9	194,3	203,4	216,2
THAEBY MODEL SEASONAL PERFORMANCE IN HEATING MODE										
(∅)	Pdesign (EN 14825)	kW	343	367	-	-	-	-	-	-
(∅)	SCOP (EN 14825)		3,44	3,38	-	-	-	-	-	-
(§)	ηs	%	135	132	-	-	-	-	-	-
THAESY MODEL SEASONAL PERFORMANCE IN HEATING MODE										
(∅)	Pdesign (EN 14825)	kW	328	355	391	-	-	-	-	-
(∅)	SCOP (EN 14825)		3,45	3,39	3,47	-	-	-	-	-
(§)	ηs	%	135	133	136	-	-	-	-	-
THAEBY-THAESY MODEL			4360	4390	4435	5500	6540	6590	6635	6670
③	Sound pressure	dB(A)	62	63	64	64	64	64	64,5	64,5
③	Sound pressure	dB(A)	57	58	59	59	59	59	59,5	60
④	Sound power	dB(A)	94	95	96	96	96	96	97	97
④	Sound power	dB(A)	89	90	91	91	91	91	92	92,5
	Scroll/step compressor	no.	4/4	4/4	4/4	5/5	6/6	6/6	6/6	6/6
	Circuits	no.	2	2	2	2	2	2	2	2
	Electrical supply	V-ph-Hz	400-3-50	400-3-50	400-3-50	400-3-50	400-3-50	400-3-50	400-3-50	400-3-50
DIMENSIONS AND WEIGHTS			4360	4390	4435	5500	6540	6590	6635	6670
	L - Width	mm	3740	3740	3740	4840	4840	4840	5940	5940
	H - Height	mm	2450	2450	2450	2450	2450	2450	2450	2450
	P - Depth	mm	2260	2260	2260	2260	2260	2260	2260	2260
⑤	THAEBY weight	kg	2700	2710	2780	3400	3580	3640	4080	4120
⑤	THAESY weight	kg	2900	2910	2980	3710	3910	3970	4490	4530

Data at the following conditions:

- ① Air: 35°C - Water: 12/7°C.
 - ② Air: 7°C, D.B. 6°C W.B. - Water: 40/45°C.
 - ③ In open field (Q = 2) at 10 m from the unit.
 - ④ Total sound power level in dB(A) based on measurements carried out in accordance with regulation UNI EN-ISO 9614.
 - ⑤ Weight referred to the unladen unit not accessorised.
 - ESEER = (European seasonal EER) - Average European seasonal efficiency.
 - ★ ESEER with Adaptive Function Plus software. ESEER+ is not Eurovent certified.
 - TCAESY - THAESY silenced versions
- Performance according to EN 14511:2013
- (∅) In Average climatic conditions, low temperature application
- (§) Seasonal energy efficiency: low temperature application in Average climate (EU Regulations N°811/213 and N°813/2013)

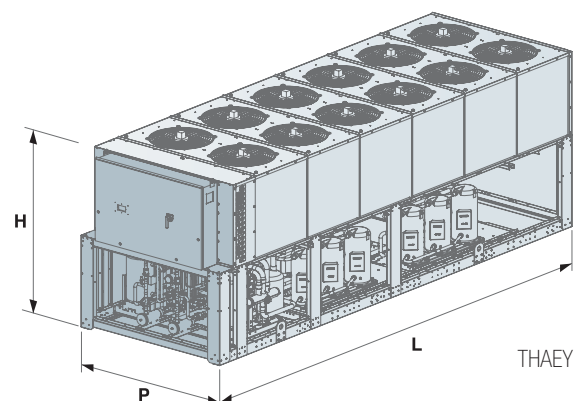

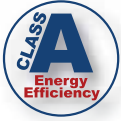

Z-Power HE

TCAVZ 2330÷2700

Cooling capacity: 315.4÷690.7 kW



TCAVZ 2510 H.E.

TCAVZ 2460 H.E. with Tank&Pump accessory

- Efficient range up to **CLASS A** with **EER ≥3.1**
- Working limits up to **55°C (HT set up)**
- Wide range of accessories
- Built-in **MASTER/SLAVE** management

High energy efficiency packaged air cooled water chillers with axial fans. Range with semi-hermetic screw compressors and R134a refrigerant gas.

Construction features

- Compressor: high energy efficiency semi-hermetic screw compressor, with star-delta limited start and complete with integral protection, casing heater and refrigerant gas outlet piping shut-off valve.
- Electronic expansion valve: as standard on all models.
- Water side heat exchanger (mod. 2330÷2460): stainless steel plate exchanger with closed cell polyurethane rubber foam insulation, complete with water flow differential pressure switch and Victaulic fittings.
- Water side heat exchanger (mod. 2510÷2700): dry expansion shell and tube exchanger with counterflow heat exchange, complete with closed cell polyurethane rubber foam insulation, water flow differential pressure switch and Victaulic fittings.
- Air side heat exchanger: finned coil with copper pipes and aluminium fins.
- Fan: electric helical fans with external rotor, equipped with internal thermal protection, accident protection grilles and proportional electronic device for continuous regulation of fan rotation speed (S version only) and fans with an EC motor with continuous regulation of the speed control (Q version only).
- Control: microprocessor electronic control.
- Structure: made of galvanised and painted steel plate with polyester powder coating.
- The unit is also complete with:
 - display of cooling circuit high/low pressure;
 - Master/Slave control up to 4 units in parallel;
 - clock board.

Versions

- B - High energy efficiency standard version (TCAVBZ).
- S - Silenced version with lower speed fans and soundproofed compressor cover (TCAVSZ).
- I - High energy efficiency soundproofed version with soundproofed compressor cover (TCAVIZ).
- Q - Supersilenced version with super-low speed fans with EC motor, high acoustic impedance and soundproofed compressor cover and a larger condensing section (TCAVQZ).

Models

- TCAVBZ: unit designed for cooling only.
- TCAVSZ: silenced unit designed for cooling only.
- TCAVIZ: soundproofed unit designed for cooling only.
- TCAVQZ: super-silenced unit designed for cooling only.

Factory fitted accessories

- HT set up for outdoor air temperature up to 55°C.
- Shell and tube evaporator (mod. 2330-2460).
- PUMP with single or double electric pump, including an automatic pump in standby. The pumps are available in the low or high head versions.
- TANK&PUMP (mod. 2330÷2460) with 1100 litre integrated buffer tank and single or double electric pump, complete with expansion tank, air vent valves, safety valve, and water side pressure gauge.
- VPF management.
- Desuperheater.
- 100% Heat recovery unit
- Thermostat with display for heat recovery unit/desuperheater.
- -10°C condensing control (as per standard in S version).
- -15°C condensing control with fans with EC motor (as per standard in the Q version).
- Power factor correction capacitors ($\cos\phi > 0.94$).
- Fan and compressor circuit breaker switches.
- Forced limit of power consumption.
- Inlet compressor shut-off valves.
- Low and high pressure gauges for each cooling circuit.
- Bottom compartment protection nets.
- Coil protection nets.
- Linear compressor capacity control (25-100 %).
- Evaporator antifreeze heater, buffer tank and heat exchangers for heat recovery if present.
- Digital input for double set-point
- Compressor oil level sensor.
- Control of min/max power supply voltage.
- 4-20 mA analogue input for shifting set-point.
- Pre-painted copper/aluminium or copper/copper coils.
- Interfaces for serial communication with other devices.
- Spring anti-vibration mounts.

Separately supplied accessories

- Remote keyboard with display.
- Rhoss supervisors for unit monitoring and remote management.
- Rhoss sequencer for integrated management of several water chillers.





TCAVBZ-TCAVSZ-TCAVIZ-TCAVQZ MODEL		2330	2350	2370	2390	2420	2460	2510	
❶	Nominal cooling capacity	kW	332,5	352,6	372,9	389,7	415,7	457,1	509,1
❶	Nominal cooling capacity	kW	324,3	343,5	361,1	378,7	406,1	442,9	494,3
❶	Nominal cooling capacity		315,4	335,4	353,3	369,2	394,2	432	482,8
❶	E.E.R.		3,12	3,11	3,11	3,10	3,11	3,11	3,11
❶	E.E.R.		3,07	3,04	3,02	2,94	3,05	3,02	2,99
❶	E.E.R.		2,93	2,93	2,9	2,82	2,92	2,9	2,87
●	E.S.E.E.R.		4	4,02	4,04	4,02	4	3,98	4
●	E.S.E.E.R.		3,93	3,94	3,95	3,95	3,95	3,92	3,85
●	E.S.E.E.R.		4,05	4,06	4,08	4,07	4,06	4,05	4,01
❷	IPLV		4,20	4,22	4,24	4,22	4,20	4,22	4,24
❷	IPLV		4,13	4,14	4,15	4,15	4,15	4,12	4,09
❷	IPLV		4,25	4,26	4,28	4,27	4,26	4,26	4,25
❶	Absorbed power	kW	106,57	113,38	119,90	125,71	133,67	146,98	163,70
❶	Absorbed power	kW	105,64	112,99	119,57	128,81	133,15	146,66	165,32
❶	Absorbed power	kW	107,65	114,47	121,83	130,92	135	148,97	168,22
TCAVBZ-TCAVSZ-TCAVQZ MODEL		2330	2350	2370	2390	2420	2460	2510	
❸	Sound pressure	dB(A)	65	65	65	65	65	65	65
❸	Sound pressure	dB(A)	59	59	59	59	59	59	59
❸	Sound pressure	dB(A)	55	55	55	55	55	55	55
❹	Sound power	dB(A)	98	98	98	98	98	98	98
❹	Sound power	dB(A)	92	92	92	92	92	92	92
❹	Sound power	dB(A)	88	88	88	88	88	88	88
	Screw/step compressor	no.	2/6	2/6	2/6	2/6	2/6	2/6	2/6
	Circuits	no.	2	2	2	2	2	2	2
	Electrical supply	V-ph-Hz	400-3-50	400-3-50	400-3-50	400-3-50	400-3-50	400-3-50	400-3-50
DIMENSIONS AND WEIGHTS		2330	2350	2370	2390	2420	2460	2510	
	L - Width	mm	4.830	4.830	4.830	4.830	5.830	5.830	5.830
	H - Height	mm	2.430	2.430	2.430	2.430	2.430	2.430	2.430
	P - Depth	mm	2.260	2.260	2.260	2.260	2.260	2.260	2.260
❺	TCAVBZ weight	kg	3490	3530	3570	3600	3860	4290	4950
❺	TCAVIZ-TCAVSZ weight	kg	3810	3850	3890	3920	4180	4610	5270
❺	TCAVQZ weight	kg	3970	4010	4050	4080	4340	4770	5430

TCAVBZ-TCAVSZ-TCAVIZ-TCAVQZ MODEL		2550	2570	2610	2640	2680	2700	
❶	Nominal cooling capacity	kW	543,5	568,4	609,1	642,6	672,2	690,7
❶	Nominal cooling capacity	kW	529,6	553,3	591,3	622,6	654,8	673,8
❶	Nominal cooling capacity		514,6	537,4	574,6	607,5	636,1	653,9
❶	E.E.R.		3,13	3,12	3,10	3,11	3,11	3,11
❶	E.E.R.		3,07	3,04	3,03	2,97	3,04	3
❶	E.E.R.		2,95	2,91	2,91	2,87	2,92	2,88
●	E.S.E.E.R.		4,05	4,04	4,07	4,04	4,01	4,01
●	E.S.E.E.R.		3,85	3,8	3,85	3,89	3,92	3,9
●	E.S.E.E.R.		3,99	4	4,03	4,13	4,14	4,15
❷	IPLV		4,29	4,34	4,34	4,34	4,34	4,35
❷	IPLV		4,08	4,08	4,12	4,17	4,20	4,22
❷	IPLV		4,27	4,30	4,31	4,34	4,35	4,37
❶	Absorbed power	kW	173,64	182,18	196,48	206,62	216,14	222,09
❶	Absorbed power	kW	172,51	182,01	195,15	209,63	215,39	224,6
❶	Absorbed power	kW	174,44	184,67	197,46	211,67	217,84	227,05
TCAVBZ-TCAVSZ-TCAVQZ MODEL		2550	2570	2610	2640	2680	2700	
❸	Sound pressure	dB(A)	66	66	66	66	66	66
❸	Sound pressure	dB(A)	60	60	60	60	60	60
❸	Sound pressure	dB(A)	56	56	56	56	56	56
❹	Sound power	dB(A)	99	99	99	99	99	99
❹	Sound power	dB(A)	93	93	93	93	93	93
❹	Sound power	dB(A)	89	89	89	89	89	89
	Screw/step compressor	no.	2/6	2/6	2/6	2/6	2/6	2/6
	Circuits	no.	2	2	2	2	2	2
	Electrical supply	V-ph-Hz	400-3-50	400-3-50	400-3-50	400-3-50	400-3-50	400-3-50
DIMENSIONS AND WEIGHTS		2550	2570	2610	2640	2680	2700	
	L - Width	mm	6.680	6.680	6.680	6.680	7.680	7.680
	H - Height	mm	2.430	2.430	2.430	2.430	2.430	2.430
	P - Depth	mm	2.260	2.260	2.260	2.260	2.260	2.260
❺	TCAVBZ weight	kg	5560	5680	5720	5740	6010	6030
❺	TCAVIZ-TCAVSZ weight	kg	5880	6000	6040	6060	6330	6350
❺	TCAVQZ weight	kg	6088	6208	6248	6268	6538	6558

Data at the following conditions:

- ❶ Air: 35°C - Water: 12/7°C.
- ❷ IPLV (Integrated Part Load Value) - ARI standard 550/590.
- ❸ In open field (Q = 2) at 10 m from the unit.
- ❹ Total sound power level in dB(A) based on measurements carried out in accordance with regulation UNI EN-ISO 9614.
- ❺ Weight refers to the accessorised unit with RPE - KRP when empty.
- ESEER = (European seasonal EER) - Average European seasonal efficiency.

■ TCAVSZ silenced versions.

■ TCAVQZ super-silenced versions.

Performance according to EN 14511:2013

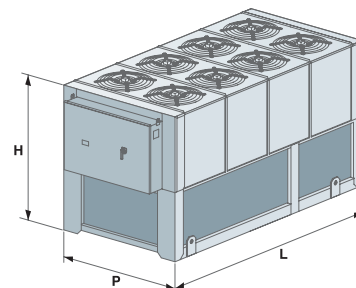



Z-Power HE

TCAVZ 2770÷21290

Cooling capacity: 721.7÷1,277.7 kW



TCAVQZ 21010 HE

- Efficient range in **CLASS A** with **EER >3.2** and **ESEER up to 4.45**
- Working limits up to **55°C (HT set up)**
- Standard electronic expansion valve
- Built-in **MASTER/SLAVE** management

High energy efficiency packaged air cooled water chillers with axial fans. Range with semi-hermetic screw compressors and R134a refrigerant gas.

Construction features

- Compressor: high energy efficiency semi-hermetic screw compressor, with star-delta limited start and complete with integral protection, casing heater and refrigerant gas outlet piping shut-off valve.
- Electronic expansion valve: as standard on all models.
- Water side heat exchanger: dry expansion shell and tube exchanger with counterflow heat exchange, complete with closed cell polyurethane rubber foam insulation, water flow differential pressure switch and Victaulic fittings.
- Air side heat exchanger: finned coil with copper pipes and aluminium fins.
- Fan: electric helical fans with external rotor, equipped with internal thermal protection, accident protection grilles and proportional electronic device for continuous fan rotation speed regulation (S version only) and fans with an EC motor with continuous regulation of the speed control (Q version only).
- Control: microprocessor electronic control.
- Structure: made of galvanised and painted steel plate with polyester powder coating.
- The unit is also complete with:
 - display of cooling circuit high/low pressure;
 - Master/Slave control up to 4 units in parallel;
 - clock board.

Versions

- B - High energy efficiency standard version (TCAVBZ).
- S - Silenced version with lower speed fans and soundproofed compressor cover (TCAVSZ).
- I - High energy efficiency soundproofed version with soundproofed compressor cover (TCAVIZ).
- Q - Supersilenced version with super-low speed fans with EC motor, high acoustic impedance and soundproofed compressor cover and a larger condensing section (TCAVQZ).

Models

- TCAVBZ: unit designed for cooling only.
- TCAVSZ: silenced unit designed for cooling only.
- TCAVIZ: soundproofed unit designed for cooling only.
- TCAVQZ: super-silenced unit designed for cooling only.

Factory fitted accessories

- HT set up for outdoor air temperature up to 55°C.
- VPF management.
- Desuperheater.
- 100% Heat recovery unit
- Thermostat with display for heat recovery unit/desuperheater.
- -10°C condensing control (as per standard in S version).
- -15°C condensing control with fans with EC motor (as per standard in the Q version).
- Power factor correction capacitors ($\cos\phi > 0.94$).
- Fan and compressor circuit breaker switches.
- Forced limit of power consumption.
- Soft starter.
- Inlet compressor shut-off valves.
- Low and high pressure gauges for each cooling circuit.
- Bottom compartment protection nets.
- Coil protection nets.
- Linear compressor capacity control (25-100%).
- Evaporator antifreeze heater and heat recovery exchangers if present.
- Digital input for double set-point
- Compressor oil level sensor.
- Control of min/max power supply voltage.
- 4-20 mA analogue input for shifting set-point.
- Low temperature water production.
- Pre-painted copper/aluminium or copper/copper coils.
- Interfaces for serial communication with other devices.
- Spring anti-vibration mounts.

Separately supplied accessories

- Remote keyboard with display.
- Rhoss supervisors for unit monitoring and remote management.
- Rhoss sequencer for integrated management of several water chillers.





TCAVBZ-TCAVSZ-TCAVIZ-TCAVQZ MODEL		2770	2830	2890	2960	21010	21040	
❶	Nominal cooling capacity	kW	762,1	828,2	884	953,9	1006,1	1033
❶	Nominal cooling capacity	kW	743,7	808,1	861,8	921,3	970,2	1000,2
❶	Nominal cooling capacity	kW	721,7	784,9	841,5	894,3	946,9	972,6
❶	E.E.R.		3,31	3,26	3,2	3,32	3,3	3,29
❶	E.E.R.		3,19	3,12	3,04	3,12	3,08	3,11
❶	E.E.R.		3,07	3,01	2,95	2,99	2,98	3,00
●	E.S.E.E.R.		4,32	4,21	4,17	4,35	4,29	4,27
●	E.S.E.E.R.		4,18	4,05	3,96	4,07	3,99	4,04
●	E.S.E.E.R.		4,41	4,34	4,26	4,38	4,34	4,38
❷	IPLV		4,63	4,57	4,51	4,66	4,65	4,63
❷	IPLV		4,48	4,39	4,28	4,37	4,33	4,37
❷	IPLV		4,65	4,57	4,48	4,61	4,58	4,59
❶	Absorbed power	kW	230,24	254,05	276,25	287,32	304,88	313,98
❶	Absorbed power	kW	233,13	259,01	283,49	295,29	315	321,61
❶	Absorbed power	kW	235,08	260,76	285,25	299,10	317,75	324,2
TCAVBZ-TCAVSZ-TCAVQZ MODEL		2770	2830	2890	2960	21010	21040	
❸	Sound pressure	dB(A)	67	67	67	68	68	68
❸	Sound pressure	dB(A)	61	61	61	62	62	62
❸	Sound pressure	dB(A)	57	58	58	59	59	59
❹	Sound power	dB(A)	100	100	100	101	101	101
❹	Sound power	dB(A)	94	94	94	95	95	95
❹	Sound power	dB(A)	90	91	91	92	92	92
	Screw/step compressor	no.	2/6	2/6	2/6	2/6	2/6	2/6
	Circuits	no.	2	2	2	2	2	2
	Electrical supply	V-ph-Hz	400-3-50	400-3-50	400-3-50	400-3-50	400-3-50	400-3-50
DIMENSIONS AND WEIGHTS		2770	2830	2890	2960	21010	21040	
	L - Width	mm	7.680	7.680	7.680	8.980	9.980	
	H - Height	mm	2.430	2.430	2.430	2.430	2.430	
	P - Depth	mm	2.260	2.260	2.260	2.260	2.260	
❺	TCAVBZ weight	kg	6070	6690	7190	7820	8350	
❺	TCAVIZ-TCAVSZ weight	kg	6390	7040	7540	8170	8700	
❺	TCAVQZ weight	kg	6598	7280	7780	8410	8940	

TCAVBZ-TCAVSZ-TCAVIZ-TCAVQZ MODEL		21080	21130	21150	21220	21290	
❶	Nominal cooling capacity	kW	1076,7	1122,4	1148,6	1213,3	1277,7
❶	Nominal cooling capacity	kW	1048,1	1096,6	1112,8	1173,9	1235,1
❶	Nominal cooling capacity	kW	1016,9	1069,8	1079,7	1139,4	1206
❶	E.E.R.		3,32	3,18	3,38	3,35	3,32
❶	E.E.R.		3,19	3,04	3,17	3,09	3,03
❶	E.E.R.		3,05	2,94	3,04	2,97	2,93
●	E.S.E.E.R.		4,35	4,16	4,39	4,35	4,33
●	E.S.E.E.R.		4,16	3,98	4,14	3,99	3,94
●	E.S.E.E.R.		4,42	4,23	4,45	4,37	4,33
❷	IPLV		4,66	4,46	4,75	4,71	4,69
❷	IPLV		4,47	4,26	4,44	4,33	4,26
❷	IPLV		4,65	4,45	4,69	4,61	4,56
❶	Absorbed power	kW	324,31	352,96	339,82	362,18	384,85
❶	Absorbed power	kW	328,56	360,72	351,04	379,9	407,62
❶	Absorbed power	kW	333,41	363,88	355,16	383,63	411,60
TCAVBZ-TCAVSZ-TCAVQZ MODEL		21080	21130	21150	21220	21290	
❸	Sound pressure	dB(A)	69	69	69	69	69
❸	Sound pressure	dB(A)	63	63	63	63	63
❸	Sound pressure	dB(A)	59	59	59	60	60
❹	Sound power	dB(A)	102	102	102	102	102
❹	Sound power	dB(A)	96	96	96	96	96
❹	Sound power	dB(A)	92	92	92	93	93
	Screw/step compressor	no.	2/6	2/6	2/6	2/6	2/6
	Circuits	no.	2	2	2	2	2
	Electrical supply	V-ph-Hz	400-3-50	400-3-50	400-3-50	400-3-50	400-3-50
DIMENSIONS AND WEIGHTS		21080	21130	21150	21220	21290	
	L - Width	mm	10.980	10.980	10.980	10.980	10.980
	H - Height	mm	2.430	2.430	2.430	2.430	2.430
	P - Depth	mm	2.260	2.260	2.260	2.260	2.260
❺	TCAVBZ weight	kg	8670	8670	8690	9020	9050
❺	TCAVIZ-TCAVSZ weight	kg	9020	9020	9310	9370	9400
❺	TCAVQZ weight	kg	9260	9260	9550	9610	9640

Data at the following conditions:

- ❶ Air: 35°C - Water: 12/7°C.
- ❷ IPLV (Integrated Part Load Value) - ARI standard 550/590.
- ❸ In open field (Q = 2) at 10 m from the unit.
- ❹ Total sound power level in dB(A) based on measurements carried out in accordance with regulation UNI EN-ISO 9614.
- ❺ Weight refers to the accessorised unit with RPE - KRP when empty.
- ESEER = (European seasonal EER) - Average European seasonal efficiency.

■ TCAVSZ silenced versions.

■ TCAVQZ super-silenced versions.

Performance according to EN 14511:2013

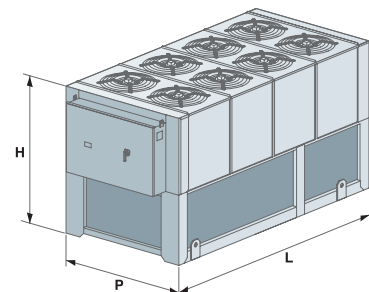

Z-Power SE

TCAVZ 1270÷1390

Cooling capacity: 259.1÷392.7 kW



TCAVBZ 1350

- Efficient and compact range in R134a
- Working limits up to 50°C
- Range with single compressor up to 390 kW
- Built-in MASTER/SLAVE management

Packaged air-cooled water chillers with axial fans.
Range with semi-hermetic screw compressors and R134a refrigerant gas.

Construction features

- Compressor: high energy efficiency semi-hermetic screw compressor, with star-delta limited start, complete with integral protection, casing heater and refrigerant gas outlet piping shut-off valve.
- Electronic expansion valve: as standard on all models.
- Water side heat exchanger: dry expansion shell and tube exchanger, complete with closed cell polyurethane rubber foam insulation, water flow differential pressure switch and Victaulic fittings.
- Air side heat exchanger: finned coil with copper pipes and aluminium fins.
- Fan: electric helical fans with external rotor, equipped with internal thermal protection, accident protection grilles and proportional electronic device for continuous fan rotation speed regulation (S version only).
- Control: microprocessor electronic control.
- Structure: made of galvanised and painted steel plate with polyester powder coating.
- The unit is also complete with:
 - display of cooling circuit high/low pressure;
 - Master/Slave control up to 4 units in parallel;
 - clock board.

Versions

- B - Standard version (TCAVBZ).
- S - Silenced version with lower speed fans and soundproofed compressor cover (TCAVSZ).
- I - Soundproofed version with soundproofed compressor cover (TCAVIZ).

Models

- TCAVBZ: unit designed for cooling only.
- TCAVSZ: silenced unit designed for cooling only.
- TCAVIZ: soundproofed unit designed for cooling only.

Factory fitted accessories

- PUMP with single or double electric pump, including an automatic pump in standby. The pumps are available in the low or high head versions.
- VPF management.
- Desuperheater.
- 100% Heat recovery unit
- Thermostat with display for heat recovery unit/desuperheater.
- -10°C condensing control (as per standard in S version).
- -15°C condensing control with fans with EC motor.
- Power factor correction capacitors ($\cos\phi > 0.94$).
- Fan and compressor circuit breaker switches.
- Forced limit of power consumption.
- Inlet compressor shut-off valves.
- Low and high pressure gauges for each cooling circuit.
- Bottom compartment protection nets.
- Coil protection nets.
- Linear capacity control compressor.
- Evaporator antifreeze heater and heat recovery exchangers if present.
- Digital input for double set-point
- Compressor oil level sensor.
- Control of min/max power supply voltage.
- 4-20 mA analogue input for shifting set-point.
- Low temperature water production.
- Pre-painted copper/aluminium or copper/copper coils.
- Interfaces for serial communication with other devices.
- Spring anti-vibration mounts.

Separately supplied accessories

- Remote keyboard with display.
- Rhoss supervisors for unit monitoring and remote management.
- Rhoss sequencer for integrated management of several water chillers.



TCAVBZ-TCAVIZ-TCAVSZ MODEL		1270	1310	1350	1390	
❶	Nominal cooling capacity	kW	269.1	307.9	352.9	392.7
❶	Nominal cooling capacity	kW	259.1	298.9	339.0	372.8
❶	E.E.R.		2.67	2.77	2.7	2.7
❶	E.E.R.		2.59	2.68	2.57	2.52
●	E.S.E.E.R.		3.37	3.48	3.38	3.37
●	E.S.E.E.R.		3.19	3.31	3.2	3.16
❶	Absorbed power	kW	100.79	111.16	130.7	145.41
❶	Absorbed power	kW	100.04	111.53	131.91	147.94
TCAVBZ-TCAVSZ MODEL		1270	1310	1350	1390	
❸	Sound pressure	dB(A)	64	65	65	65
❸	Sound pressure	dB(A)	58	59	59	59
❹	Sound power	dB(A)	97	98	98	98
❹	Sound power	dB(A)	91	92	92	92
	Electrical supply	V-ph-Hz	400-3-50	400-3-50	400-3-50	400-3-50
DIMENSIONS AND WEIGHTS		1270	1310	1350	1390	
	L - Width	mm	3830	3830	3830	3830
	H - Height	mm	2430	2430	2430	2430
	P - Depth	mm	2260	2260	2260	2260
❺	TCAVBZ weight	kg	2850	2970	3430	3530
❺	TCAVSZ weight	kg	3010	3130	3590	3690

Data at the following conditions:

- ❶ Air: 35°C - Water: 12/7°C.
- ❸ In open field (Q = 2) at 10 m from the unit.
- ❹ Total sound power level in dB(A) based on measurements carried out in accordance with regulation UNI EN-ISO 9614.
- ❺ Weight refers to the accessorised unit with RPE - KRP when empty.
- ESEER = (European seasonal EER) - Average European seasonal efficiency.
- TCAVSZ silenced versions.

Performance according to EN 14511:2013

TCAVZ unit under inspection at Rhoss laboratory: R&D Lab.

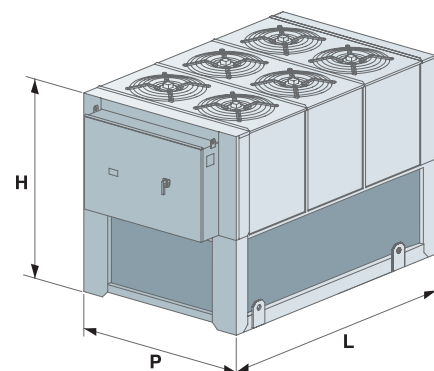

Z-Power SE

TCAVZ 2331÷2701

Cooling capacity: 320÷688.5 kW



TCAVZ 2641

TCAVZ 2391 with the
Tank&Pump accessory

- Efficient range in R134a
- Working limits up to 50°C
- TANK&PUMP set up up to 500 kW
- Built-in MASTER/SLAVE management

Packaged air-cooled water chillers with axial fans.

Range with semi-hermetic screw compressors and R134a refrigerant gas.

Construction features

- Compressor: high energy efficiency semi-hermetic screw compressor, with star-delta limited start and complete with integral protection, casing heater and refrigerant gas outlet piping shut-off valve.
- Electronic expansion valve: as standard on all models.
- Water side heat exchanger (mod. 2331÷2511): stainless steel plate exchanger with closed cell polyurethane foam rubber insulation, complete with water flow differential pressure switch and Victaulic fittings.
- Water side heat exchanger (mod. 2551÷2701): dry expansion shell and tube exchanger with counterflow heat exchange, complete with closed cell polyurethane rubber foam insulation, water flow differential pressure switch and Victaulic fittings.
- Air side heat exchanger: finned coil with copper pipes and aluminium fins.
- Fan: electric helical fans with external rotor, equipped with internal thermal protection, accident protection grilles and proportional electronic device for continuous fan rotation speed regulation (S version only).
- Control: microprocessor electronic control.
- Structure: made of galvanised and painted steel plate with polyester powder coating.
- The unit is also complete with:
 - display of cooling circuit high/low pressure;
 - Master/Slave control up to 4 units in parallel;
 - clock board.

Versions

- B - Standard version (TCAVBZ).
- S - Silenced version with lower speed fans and soundproofed compressor cover (TCAVZS).
- I - Soundproofed version with soundproofed compressor cover (TCAVIZ).

Models

- TCAVBZ: unit designed for cooling only.
- TCAVZS: silenced unit intended for cooling only.
- TCAVIZ: soundproofed unit designed for cooling only.

Factory fitted accessories

- Shell and tube evaporator (mod. 2331÷2511).
- PUMP with single or double electric pump, including an automatic pump in standby. The pumps are available in the low or high head versions.
- TANK&PUMP (mod. 2331÷2511) with 1000 litre integrated buffer tank and single or double electric pump, complete with expansion tank, air vent valves, safety valve and water side pressure gauge.
- VPF management:
- Desuperheater.
- 100% Heat recovery unit
- Thermostat with display for heat recovery unit/desuperheater.
- -10°C condensing control (as per standard in S version).
- -15°C condensing control with fans with EC motor.
- Power factor correction capacitors ($\cos\phi > 0.94$).
- Fan and compressor circuit breaker switches.
- Forced limit of power consumption.
- Soft starter.
- Inlet compressor shut-off valves.
- Low and high pressure gauges for each cooling circuit.
- Bottom compartment protection nets.
- Coil protection nets.
- Linear compressor capacity control (25-100 %).
- Evaporator antifreeze heater, buffer tank and heat exchangers for heat recovery if present.
- Digital input for double set-point
- Compressor oil level sensor.
- Control of min/max power supply voltage.
- 4-20 mA analogue input for shifting set-point.
- Low temperature water production.
- Pre-painted copper/aluminium or copper/copper coils.
- Interfaces for serial communication with other devices.
- Spring anti-vibration mounts.

Separately supplied accessories

- Remote keyboard with display.
- Rhoss supervisors for unit monitoring and remote management.
- Rhoss sequencer for integrated management of several water chillers.



TCAVBZ-TCAVSZ-TCAVIZ MODEL		2331	2351	2371	2391	2421	2461	2511	
❶	Nominal cooling capacity	kW	330,5	350	369,8	389,3	412,8	453,4	506,8
❶	Nominal cooling capacity	kW	320	338,3	358,4	372,6	400,3	438,1	485,8
❶	E.E.R.		2,92	2,93	2,9	2,9	2,91	2,9	2,9
❶	E.E.R.		2,83	2,81	2,78	2,69	2,83	2,78	2,74
●	E.S.E.E.R.		3,92	3,93	3,93	3,95	3,95	3,88	3,81
●	E.S.E.E.R.		3,72	3,75	3,78	3,8	3,82	3,7	3,54
❷	IPLV		4,11	4,11	4,12	4,13	4,15	4,07	3,98
❷	IPLV		3,90	3,93	3,96	3,99	4,01	3,88	3,74
❶	Absorbed power	kW	113,18	119,45	127,52	134,24	141,86	156,34	174,76
❶	Absorbed power	kW	113,07	120,39	128,92	138,51	141,45	157,59	177,3
TCAVBZ-TCAVSZ MODEL		2331	2351	2371	2391	2421	2461	2511	
❸	Sound pressure	dB(A)	64	64	64	64	65	65	65
❸	Sound pressure	dB(A)	58	58	58	58	59	59	59
❹	Sound power	dB(A)	97	97	97	97	98	98	98
❹	Sound power	dB(A)	91	91	91	91	92	92	92
	Screw/step compressor	no.	2/6	2/6	2/6	2/6	2/6	2/6	2/6
	Electrical supply	V-ph-Hz	2	2	2	2	2	2	2
	Circuits	no.	400-3-50	400-3-50	400-3-50	400-3-50	400-3-50	400-3-50	400-3-50
DIMENSIONS AND WEIGHTS		2331	2351	2371	2391	2421	2461	2511	
	L - Width	mm	3.830	3.830	3.830	3.830	4.830	4.830	4.830
	H - Height	mm	2.430	2.430	2.430	2.430	2.430	2.430	2.430
	P - Depth	mm	2.260	2.260	2.260	2.260	2.260	2.260	2.260
❺	TCAVBZ weight	kg	3080	3100	3130	3200	3520	3950	4300
❺	TCAVIZ-TCAVSZ weight	kg	3400	3420	3450	3520	3840	4270	4620

TCAVBZ-TCAVSZ-TCAVIZ MODEL		2551	2571	2611	2641	2681	2701	
❶	Nominal cooling capacity	kW	539,4	563	607,1	644,8	669,1	688,5
❶	Nominal cooling capacity	kW	523,1	545,1	583,3	615,4	649,7	669,3
❶	E.E.R.		2,93	2,9	2,9	2,9	2,88	2,86
❶	E.E.R.		2,85	2,8	2,74	2,72	2,78	2,75
●	E.S.E.E.R.		3,8	3,83	3,85	3,84	3,8	3,8
●	E.S.E.E.R.		3,62	3,72	3,72	3,72	3,7	3,65
❷	IPLV		4,07	4,15	4,13	4,11	4,11	4,12
❷	IPLV		3,87	3,99	3,98	3,97	3,96	3,95
❶	Absorbed power	kW	184,1	194,14	209,34	222,34	232,33	240,73
❶	Absorbed power	kW	183,54	194,68	212,88	226,25	233,71	243,38
TCAVBZ-TCAVSZ MODEL		2551	2571	2611	2641	2681	2701	
❸	Sound pressure	dB(A)	65	65	65	65	66	66
❸	Sound pressure	dB(A)	59	59	59	59	60	60
❹	Sound power	dB(A)	98	98	98	98	99	99
❹	Sound power	dB(A)	92	92	92	92	93	93
	Screw/step compressor	no.	2/6	2/6	2/6	2/6	2/6	2/6
	Electrical supply	V-ph-Hz	2	2	2	2	2	2
	Circuits	no.	400-3-50	400-3-50	400-3-50	400-3-50	400-3-50	400-3-50
DIMENSIONS AND WEIGHTS		2551	2571	2611	2641	2681	2701	
	L - Width	mm	5.830	5.830	5.830	5.830	6.680	6.680
	H - Height	mm	2.430	2.430	2.430	2.430	2.430	2.430
	P - Depth	mm	2.260	2.260	2.260	2.260	2.260	2.260
❺	TCAVBZ weight	kg	4780	4800	4920	5010	5560	5580
❺	TCAVIZ-TCAVSZ weight	kg	5100	5120	5240	5330	5880	5900

Data at the following conditions:

- ❶ Air: 35°C - Water: 12/7°C.
- ❷ IPLV (Integrated Part Load Value) - ARI standard 550/590.
- ❸ In open field (Q = 2) at 10 m from the unit.
- ❹ Total sound power level in dB(A) based on measurements carried out in accordance with regulation UNI EN-ISO 9614.
- ❺ Weight refers to the accessorised unit with RPE - KRP when empty.
- ESEER = (European seasonal EER) - Average European seasonal efficiency.
- TCAVSZ silenced versions.

Performance according to EN 14511:2013

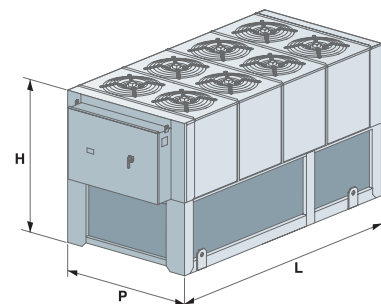

Z-Power SE

TCAVZ 2710÷21600

Cooling capacity: 687÷1,609.7 kW



TCAVZ 21600 with the DS accessory and pump unit

- Efficient range in R134a
- Installation flexibility up to 1,600 kW
- Standard electronic expansion valve
- Built-in MASTER/SLAVE management

Packaged air-cooled water chillers with axial fans.
Range with semi-hermetic screw compressors and R134a refrigerant gas.

Construction features

- Compressor: high energy efficiency semi-hermetic screw compressor, with star-delta limited start and complete with integral protection, casing heater and refrigerant gas outlet piping shut-off valve.
- Electronic expansion valve: as standard on all models.
- Water side heat exchanger: dry expansion shell and tube exchanger with counterflow heat exchange, complete with closed cell polyurethane rubber foam insulation, water flow differential pressure switch and Victaulic fittings.
- Air side heat exchanger: finned coil with copper pipes and aluminium fins.
- Fan: electric helical fans with external rotor, equipped with internal thermal protection, accident protection grilles and proportional electronic device for continuous fan rotation speed regulation (S version only).
- Control: microprocessor electronic control.
- Structure: made of galvanised and painted steel plate with polyester powder coating.
- The unit is also complete with:
 - display of cooling circuit high/low pressure;
 - Master/Slave control up to 4 units in parallel;
 - clock board.

Versions

- B - Standard version (TCAVBZ).
- S - Silenced version with lower speed fans and soundproofed compressor cover (TCAVSZ).
- I - Soundproofed version with soundproofed compressor cover (TCAVIZ).

Models

- TCAVBZ: unit designed for cooling only.
- TCAVSZ: silenced unit designed for cooling only.
- TCAVIZ: soundproofed unit designed for cooling only.

Factory fitted accessories

- VPF management.
- Desuperheater.
- 100% Heat recovery unit
- Thermostat with display for heat recovery unit/desuperheater.
- -10°C condensing control (as per standard in S version).
- -15°C condensing control with fans with EC motor.
- Power factor correction capacitors ($\cos\phi > 0.94$).
- Fan and compressor circuit breaker switches.
- Forced limit of power consumption.
- Soft starter.
- Inlet compressor shut-off valves.
- Low and high pressure gauges for each cooling circuit.
- Bottom compartment protection nets.
- Coil protection nets.
- Linear compressor capacity control (25-100 %).
- Evaporator antifreeze heater and heat recovery exchangers if present.
- Digital input for double set-point
- Compressor oil level sensor.
- Control of min/max power supply voltage.
- 4-20 mA analogue input for shifting set-point.
- Low temperature water production.
- Pre-painted copper/aluminium or copper/copper coils.
- Interfaces for serial communication with other devices.
- Spring anti-vibration mounts.

Separately supplied accessories

- Remote keyboard with display.
- Rhoss supervisors for unit monitoring and remote management.
- Rhoss sequencer for integrated management of several water chillers.



TCAVBZ-TCAVSZ-TCAVIZ MODEL		2710	2750	2810	2870	2940	2990	21020	
❶	Nominal cooling capacity	kW	706,7	747,7	806,5	860,1	932,7	981,2	1011,4
❶	Nominal cooling capacity	kW	687	728,8	783,3	835	906,1	950,9	980,8
❶	E.E.R.		2,91	2,93	2,92	2,87	2,98	2,94	3
❶	E.E.R.		2,77	2,8	2,79	2,73	2,83	2,77	2,83
●	E.S.E.E.R.		3,8	3,57	3,54	3,39	3,65	3,59	3,65
●	E.S.E.E.R.		3,65	3,42	3,39	3,22	3,46	3,36	3,45
❷	IPLV		4,10	4,12	4,09	4,03	4,17	4,14	4,21
❷	IPLV		3,92	3,94	3,91	3,83	3,95	3,89	3,97
❶	Absorbed power	kW	242,85	255,19	276,2	299,69	312,99	333,74	337,13
❶	Absorbed power	kW	248,01	260,29	280,75	305,86	320,18	343,29	346,57
TCAVBZ-TCAVSZ MODEL		2710	2750	2810	2870	2940	2990	21020	
❸	Sound pressure	dB(A)	67	67	67	70	68	68	68
❸	Sound pressure	dB(A)	61	61	61	64	62	62	62
❹	Sound power	dB(A)	100	100	100	103	101	101	101
❹	Sound power	dB(A)	94	94	94	97	95	95	95
	Screw/step compressor	no.	2/6	2/6	2/6	2/6	2/6	2/6	2/6
	Circuits	no.	2	2	2	2	2	2	2
	Electrical supply	V-ph-Hz	400-3-50	400-3-50	400-3-50	400-3-50	400-3-50	400-3-50	400-3-50
DIMENSIONS AND WEIGHTS		2710	2750	2810	2870	2940	2990	21020	
	L - Width	mm	6.680	6.680	7.680	7.680	7.680	7.680	7.680
	H - Height	mm	2.430	2.430	2.430	2.430	2.430	2.430	2.430
	P - Depth	mm	2.260	2.260	2.260	2.260	2.260	2.260	2.260
❺	TCAVBZ weight	kg	5590	5600	6490	6990	7020	7040	7220
❺	TCAVIZ-TCAVSZ weight	kg	5910	5920	6840	7340	7370	7390	7570

TCAVBZ-TCAVSZ-TCAVIZ MODEL		21060	21110	21180	21250	21330	21400	21500	21600	
❶	Nominal cooling capacity	kW	1048,6	1104	1175,6	1249,7	1327,7	1404,4	1497,6	1609,7
❶	Nominal cooling capacity	kW	1016,9	1068,7	1138,9	1207,3	1283,5	1347,9	1441,7	1542,3
❶	E.E.R.		3,1	2,95	3,03	3,1	3,1	3,1	3,1	3,1
❶	E.E.R.		2,92	2,75	2,81	2,86	2,87	2,87	2,84	2,76
●	E.S.E.E.R.		3,81	3,63	3,69	3,77	3,8	3,85	3,9	4,02
●	E.S.E.E.R.		3,58	3,37	3,4	3,48	3,5	3,67	3,66	3,67
❷	IPLV		4,34	4,14	4,25	4,35	4,36	4,30	4,33	4,39
❷	IPLV		4,09	3,85	3,93	4,02	4,02	4,01	4,00	3,87
❶	Absorbed power	kW	338,26	374,24	387,99	403,13	428,29	453,03	483,10	519,26
❶	Absorbed power	kW	348,25	388,62	405,3	422,13	447,21	469,65	507,64	558,80
TCAVBZ-TCAVSZ MODEL		21060	21110	21180	21250	21330	21400	21500	21600	
❸	Sound pressure	dB(A)	69	69	69	69	70	71	71	
❸	Sound pressure	dB(A)	63	63	63	63	64	65	65	
❹	Sound power	dB(A)	102	102	102	102	103	104	104	
❹	Sound power	dB(A)	96	96	96	96	97	98	98	
	Screw/step compressor	no.	2/6	2/6	2/6	2/6	2/6	2/6	2/6	
	Circuits	no.	2	2	2	2	2	2	2	
	Electrical supply	V-ph-Hz	400-3-50	400-3-50	400-3-50	400-3-50	400-3-50	400-3-50	400-3-50	
DIMENSIONS AND WEIGHTS		21060	21110	21180	21250	21330	21400	21500	21600	
	L - Width	mm	7.680	8.980	8.980	8.980	9.980	10.980	12.980	
	H - Height	mm	2.430	2.430	2.430	2.430	2.430	2.430	2.430	
	P - Depth	mm	2.260	2.260	2.260	2.260	2.260	2.260	2.260	
❺	TCAVBZ weight	kg	7383	7760	8170	8190	8820	9310	10220	
❺	TCAVIZ-TCAVSZ weight	kg	7733	8110	8520	8540	9170	9660	10780	

Data at the following conditions:

- ❶ Air: 35°C - Water: 12/7°C.
- ❷ IPLV (Integrated Part Load Value) - ARI standard 550/590.
- ❸ In open field (Q = 2) at 10 m from the unit.
- ❹ Total sound power level in dB(A) based on measurements carried out in accordance with regulation UNI EN-ISO 9614.
- ❺ Weight refers to the accessorised unit with RPE - KRP when empty.
- ESEER = (European seasonal EER) - Average European seasonal efficiency.
- TCAVSZ silenced versions.

Performance according to EN 14511:2013

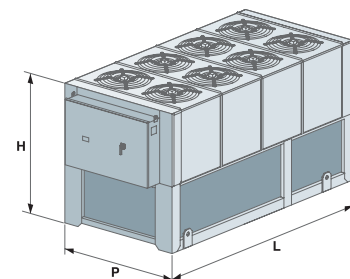

Z-Power VFD

TCAIZ 2520÷2900

Cooling capacity: 516÷903 kW

INVERTER



TCAIZ 2600

- Screw compressor with variable Vi suitable for all applications
- Continuous power modulation: 20-100%
- High energy efficiency EC fans (brushless)
- ESEER up to 4.9

Packaged air-cooled water chillers with axial fans.
Range with semi-hermetic screw compressors with variable Vi, inverter regulation and R134a refrigerant gas.

Construction features

- Compressor: high energy efficiency semi-hermetic screw compressor with variable Vi intrinsic compression ratio, star-delta limited start, inverter rotation regulation, complete with integral protection, casing heater and refrigerant gas delivery and outlet piping shut-off valve.
- Electronic expansion valve: as standard on all models.
- Water side heat exchanger: dry expansion shell and tube exchanger, complete with closed cell polyurethane rubber foam insulation, water flow differential pressure switch and Victaulic fittings.
- Air side heat exchanger: finned coil with copper pipes and aluminium fins.
- Fan: electric axial fans with EC motor with continuous adjustment of the rotation speed, equipped with internal thermal protection and complete with protection grilles.
- Control: microprocessor electronic control.
- Structure: made of galvanised and painted steel plate with polyester powder coating.
- The unit is also complete with:
 - display of cooling circuit high/low pressure;
 - fan and compressor circuit breaker switches;
 - clock board.

Versions

- I - Soundproofed version with high acoustic impedance and soundproofed compressor cover (TCAIZ).
- S - Silenced version with lower speed fans and high acoustic impedance and soundproofed compressor cover (TCAISZ).

Models

- TCAIZ: soundproofed unit designed for cooling only.
- TCAISZ: silenced unit designed for cooling only.

Factory fitted accessories

- Low and high pressure gauges for each cooling circuit.
- Bottom compartment protection grilles.
- Coil protection nets.
- Evaporator antifreeze heater.
- Digital input for double set-point.
- Control of min/max power supply voltage.
- 4-20 mA analogue input for shifting set-point.
- Copper/pre-painted aluminium or copper/copper coils.
- Interfaces for serial communication with other devices.
- Spring anti-vibration mountings.

Separately supplied accessories

- Remote keyboard with display.





TCAIHZ MODEL		2520	2600	2670	2780	2900	
❶	Nominal cooling capacity	kW	516	600	673	780	903
❶	E.E.R.		2,85	2,91	2,90	2,95	2,90
●	E.S.E.E.R.		4,82	4,88	4,87	4,89	4,85
❶	Absorbed power	kW	180,9	205,9	231,7	264,2	311,8
❸	Sound pressure	dB(A)	63	64	64	65	66
❹	Sound power	dB(A)	95	96	97	98	99
	Screw/step compressor	no.	2/INFINITE	2/INFINITE	2/INFINITE	2/INFINITE	2/INFINITE
	Circuits	no.	2	2	2	2	2
	Electrical supply	V-ph-Hz	400-3-50	400-3-50	400-3-50	400-3-50	400-3-50
SIZES		2520	2600	2670	2780	2900	
	L - Width	mm	5.830	5.830	6.680	6.680	7.680
	H - Height	mm	2.430	2.430	2.430	2.430	2.430
	P - Depth	mm	2.260	2.260	2.260	2.260	2.260

Data at the following conditions:

- ❶ Air: 35°C - Water: 12/7°C.
- ❸ In open field (Q = 2) at 10 m from the unit.
- ❹ Total sound power level in dB(A) based on measurements carried out in accordance with regulation UNI EN-ISO 9614.
- ESEER = (European seasonal EER) - Average European seasonal efficiency.

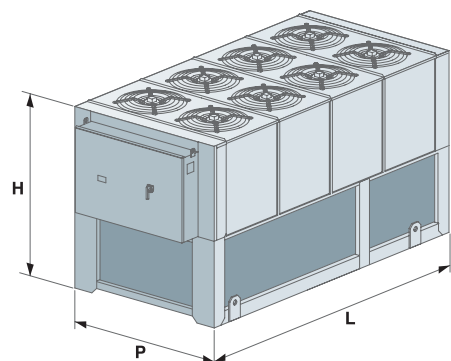

Z-Power FREECOOLING

TFAVBZ - TFAVIZ - TFAVSZ 2420÷21100

Cooling capacity: 469÷1.216 kW



- High efficiency
- Standard electronic expansion valve
- Extended operation limits

Freecooling mode air-cooled water chillers with axial fans.
Range with semi-hermetic screw compressors and R134a refrigerant gas.

Construction features

- Compressor: high energy efficiency semi-hermetic screw compressor, with star-delta limited start and complete with integral protection, casing heater and refrigerant gas outlet piping shut-off valve.
- 2 circuits/ 6 capacity steps.
- Water side heat exchanger: counterflow dry expansion shell and tube type, complete with: differential pressure switch, air vent valve, water drain tap, closed cell polyurethane foam rubber insulation with protection film against UVA rays. Victaulic connections.
- Air side heat exchanger: consisting of coil in copper pipes and aluminium fins divided into two sections: one dedicated to the condensation of the refrigerant gas and one dedicated to cooling the water in free-cooling mode.
- 3-way modulating valve to divert the water flow from the system towards the free-cooling coil or directly towards the evaporator.
- Fan: external rotor axial type electric fans, equipped with internal thermal protection, accident protection grilles and a proportional electronic device for pressurised and continuous fan rotation speed regulation up to an outdoor air temperature of -15°C.
- Control: electronic microprocessor control prepared for the connection with the main BMS available on the market (MODBUS RTU, LON, BacNet).
- Structure: load bearing structure made of galvanised sheet steel and painted with polyester powders.
- The unit is also complete with:
 - display of cooling circuit high and low pressure;
 - clock board

Versions

- B - High efficiency standard version (TFAVBZ).
- I - Soundproofed version with soundproofed compressor cover (TFAVIZ).
- S - Silenced version with soundproofed compressor cover and low speed fans (TFAVSZ).

Models

- TFAVBZ: high efficiency unit in Freecooling mode.
- TFAVIZ : soundproofed unit in Freecooling mode.
- TFAVSZ : silenced unit in Freecooling mode.

Factory fitted accessories

- -20°C condensation control with fans with EC motor.
- Power factor correction capacitors ($\cos\phi > 0.94$).
- Compressor and fan thermal overload switches.
- Forced limit of power consumption.
- Inlet compressor shut-off valves.
- Low and high pressure gauges for each refrigerant circuit.
- Bottom compartment protection grilles.
- Coil protection grilles.
- Coil protection metal filter.
- Linear capacity compressor control (25-100 %).
- Evaporator antifreeze resistance.
- Digital input for double set-point.
- Water low temperature.
- High pressure double safety valve with exchanger tap.
- Stainless steel cooling circuit.
- Electrical panel resistance
- Soft starter.
- Compressor oil level sensor.
- Control of min/max power supply voltage.
- 4-20 mA analogue input for shifting set-point.
- Copper/pre-painted aluminium or copper/copper coils.
- Interfaces for serial communication with other devices.
- Spring anti-vibration mounts.

Separately supplied accessories

- Remote keypad with display.
- Rhoss supervisors for unit monitoring and remote management.



TFAVBZ - TFAVIZ - TFAVSZ MODEL		2420	2450	2500	2560	2660	2750
FREE-COOLING OFF							
①	Nominal cooling capacity	kW	481	512	574	636	825
①	Nominal cooling capacity	kW	469	499	555	618	811
①	E.E.R.		3,79	3,79	3,7	3,72	3,74
①	E.E.R.		3,78	3,78	3,6	3,68	3,75
①	Absorbed power	kW	127	135	155	171	202
①	Absorbed power	kW	124	132	154	168	216
FREE-COOLING ON 100%							
②	Nominal cooling capacity	kW	481	512	574	636	825
②	Nominal cooling capacity	kW	469	499	555	618	811
②	E.E.R.		24,05	25,6	28,7	26,5	23,63
②	E.E.R.		37,50	39,89	44,43	41,19	36,84
②	Absorbed power	kW	20	20	20	24	32
②	Absorbed power	kW	12,5	12,5	12,5	15	20
②	Total Free-cooling Temperature	°C	2,4	1,8	1,1	1,8	2,3
②	Total Free-cooling Temperature	°C	1,2	0,5	0	0,8	0,5
TFAVBZ - TFAVSZ MODEL							
③	Sound pressure	dB(A)	65	65	65	66	68
③	Sound pressure	dB(A)	60	60	60	60	62
④	Sound power	dB(A)	98	98	98	99	101
④	Sound power	dB(A)	92	92	92	93	95
	Scroll/step compressor	no.	2/6	2/6	2/6	2/6	2/6
	Circuits	no.	2	2	2	2	2
	Electrical supply	V-ph-Hz	400-3-50	400-3-50	400-3-50	400-3-50	400-3-50
DIMENSIONS AND WEIGHTS							
	L - Width	mm	6130	6130	6130	7160	10080
	H - Height	mm	2580	2580	2580	2580	2580
	P - Depth	mm	2260	2260	2260	2260	2260
TFAVBZ - TFAVIZ - TFAVSZ MODEL							
FREE-COOLING OFF							
①	Nominal cooling capacity	kW	885	944	1019	1093	1155
①	Nominal cooling capacity	kW	867	922	1000	1071	1129
①	E.E.R.		3,71	3,66	3,69	3,72	3,68
①	E.E.R.		3,66	3,57	3,68	3,69	3,61
①	Absorbed power	kW	238,5	258	276	294	314
①	Absorbed power	kW	237	258	272	290	313
FREE-COOLING ON 100%							
②	Nominal cooling capacity	kW	885	944	1019	1093	1155
②	Nominal cooling capacity	kW	867	922	1000	1071	1129
②	E.E.R.		27,66	29,5	25,48	27,33	28,88
②	E.E.R.		43,36	46,12	39,99	42,84	45,15
②	Absorbed power	kW	32	32	40	40	40
②	Absorbed power	kW	20	20	25	25	25
②	Total Free-cooling Temperature	°C	1,2	0,6	1,1	1,6	1,1
②	Total Free-cooling Temperature	°C	0	-0,7	0	0,3	-0,5
TFAVBZ - TFAVSZ MODEL							
③	Sound pressure	dB(A)	68	68	69	69	69
③	Sound pressure	dB(A)	62	62	63	63	63
④	Sound power	dB(A)	101	101	102	102	102
④	Sound power	dB(A)	95	95	96	96	96
	Scroll/step compressor	no.	2/6	2/6	2/6	2/6	2/6
	Circuits	no.	2	2	2	2	2
	Electrical supply	V-ph-Hz	400-3-50	400-3-50	400-3-50	400-3-50	400-3-50
DIMENSIONS AND WEIGHTS							
	L - Width	mm	10080	10080	12080	12080	12080
	H - Height	mm	2580	2580	2580	2580	2580
	P - Depth	mm	2260	2260	2260	2260	2260

Data at the following conditions:

- ① Air: 30°C - Water: 15/10°C - Ethylene glycol 30%.
 - ② Water: 15/10°C - Ethylene glycol 30%.
 - ③ In open field (Q = 2) at 10 m from the unit on the coil side.
 - ④ Total sound power level in dB(A) based on measurements carried out in accordance with regulation UNI EN-ISO 9614.
- TFAESY silenced version.

Z-Power HP

THAVZ 2400÷2680

Cooling capacity: 382.6÷677.6 kW - Heating capacity: 410.6÷702.6 kW



THAVSZ 2530

- Efficient heat pumps in R134a
- Extended operation limits
- Production of hot water up to 55°C
- Built-in MASTER/SLAVE management

Packaged reversible air-cooled heat pumps with axial fans.
Range with semi-hermetic screw compressors and R134a refrigerant gas.

Construction features

- Compressor: high energy efficiency semi-hermetic screw compressor, with star-delta limited start and complete with integral protection, casing heater, refrigerant gas and delivery outlet piping shut-off valve and compressor oil level sensor.
- Electronic expansion valve: as standard on all models.
- Water side heat exchanger: dry expansion shell and tube exchanger with counterflow heat exchange, complete with closed cell polyurethane rubber foam insulation, water flow differential pressure switch and Victaulic fittings.
- Air side heat exchanger: finned coil with copper pipes and aluminium fins.
- Fan: electric helical fans with external rotor, equipped with internal thermal protection, accident protection grilles and proportional electronic device for continuous fan rotation speed regulation (S version only).
- Control: microprocessor electronic control.
- Structure: made of galvanised and painted steel plate with polyester powder coating.
- The unit is also complete with:
 - display of cooling circuit high/low pressure;
 - Master/Slave control up to 4 units in parallel;
 - clock board.

Versions

- B - Standard version (THAVBZ).
- S - Silenced version with lower speed fans and soundproofed compressor cover (THAVSZ).
- I - Soundproofed version with soundproofed compressor cover (THAVIZ).

Models

- THAVBZ: heat pump unit.
- THAVSZ: super-silenced heat pump unit.
- THAVIZ: soundproofed heat pump unit.

Factory fitted accessories

- VPF management.
- Desuperheater.
- Thermostat with display for desuperheater.
- -10°C condensing control (as per standard in S version).
- -15°C condensing control with fans with EC motor.
- Power factor correction capacitors ($\cos\phi > 0.94$).
- Fan and compressor circuit breaker switches.
- Forced limit of power consumption.
- Inlet compressor shut-off valves.
- Low and high pressure gauges for each cooling circuit.
- Bottom compartment protection nets.
- Compressors with linear capacity control (25-100 %)
- Coil protection nets.
- Evaporator antifreeze heater and heat recovery exchangers if present.
- Digital input for double set-point
- Control of min/max power supply voltage.
- 4-20 mA analogue input for shifting set-point.
- Pre-painted copper/aluminium or copper/copper coils.
- Interfaces for serial communication with other devices.
- Spring anti-vibration mounts.

Separately supplied accessories

- Remote keyboard with display.
- Rhoss supervisors for unit monitoring and remote management.
- Rhoss sequencer for integrated management of several water chillers.



THAVBZ-THAVSZ-THAVIZ MODEL		2400	2460	2530	2600	2680	
②	Nominal heating capacity	kW	427,8	488,2	566,1	622	702,6
②	Nominal heating capacity	kW	410,6	469	542,8	596,8	674,4
②	C.O.P.		2,98	3,03	3,13	3,13	3,15
②	C.O.P.		2,88	2,93	3,02	3,02	3,04
①	Nominal cooling capacity	kW	398,5	462,1	529,3	598,2	677,6
①	Nominal cooling capacity	kW	382,6	444,3	508,6	574,3	650,8
①	E.E.R.		2,66	2,76	2,82	2,93	2,96
①	E.E.R.		2,57	2,67	2,73	2,83	2,86
②	Absorbed power	kW	143,56	161,12	180,86	198,72	223,05
②	Absorbed power	kW	142,57	160,07	179,74	197,62	221,84
①	Absorbed power	kW	149,81	167,43	187,7	204,16	228,92
①	Absorbed power	kW	148,87	166,4	186,3	202,93	227,55
THAVBZ MODEL SEASONAL PERFORMANCE IN HEATING MODE							
(∅)	Pdesign (EN 14825)	kW	354	-	-	-	-
(∅)	SCOP (EN 14825)		3,13	-	-	-	-
(S)	ηs	%	122	-	-	-	-
THAVIZ MODEL SEASONAL PERFORMANCE IN HEATING MODE							
(∅)	Pdesign (EN 14825)	kW	354	-	-	-	-
(∅)	SCOP (EN 14825)		3,13	-	-	-	-
(S)	ηs	%	122	-	-	-	-
THAVSZ MODEL SEASONAL PERFORMANCE IN HEATING MODE							
(∅)	Pdesign (EN 14825)	kW	345	394	-	-	-
(∅)	SCOP (EN 14825)		3,05	3,10	-	-	-
(S)	ηs	%	119	121	-	-	-
THAVBZ-THAVSZ MODEL			2400	2460	2530	2600	2680
③	Sound pressure	dB(A)	64	65	65	66	67
③	Sound pressure	dB(A)	58	59	59	60	61
④	Sound power	dB(A)	98	98	98	99	99
④	Sound power	dB(A)	92	92	92	93	93
	Screw/step compressor	no.	2/6	2/6	2/6	2/6	2/6
	Circuits	no.	2	2	2	2	2
	Electrical supply	V-ph-Hz	400-3-50	400-3-50	400-3-50	400-3-50	400-3-50
DIMENSIONS AND WEIGHTS			2400	2460	2530	2600	2680
	L - Width	mm	5130	6130	6130	6980	7980
	H - Height	mm	2430	2430	2430	2430	2430
	P - Depth	mm	2260	2260	2260	2260	2260
⑤	THAVBZ weight	kg	4315	5350	5740	6320	7210
⑤	THAVSZ-THAVIZ weight	kg	4665	5700	6090	6670	7560

Data at the following conditions:

- ① Air: 35°C - Water: 12/7°C.
- ② Air: 7°C, D.B. 6°C W.B.- Water: 40/45°C.
- ③ In open field (Q = 2) at 10 m from the unit.
- ④ Total sound power level in dB(A) based on measurements carried out in accordance with regulation UNI EN-ISO 9614.
- ⑤ Weight refers to the accessorised unit with RPE - KRP when empty.
- ESEER = (European seasonal EER) - Average European seasonal efficiency.
- THAVSZ silenced version.

Performance according to EN 14511:2013

(∅) In Average climatic conditions, low temperature application

(S) Seasonal energy efficiency: low temperature application in Average climate (EU Regulations N°811/213 and N°813/2013)

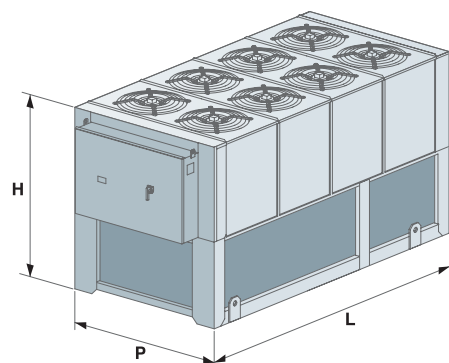

Low consumption Mini-Y C - TCCEY-THCEY 105÷111

Low consumption Compact-Y C - TCCEY-THCEY 114÷128

Low consumption Y-Pack C-PF - TCCEY-THCEY 233÷2160

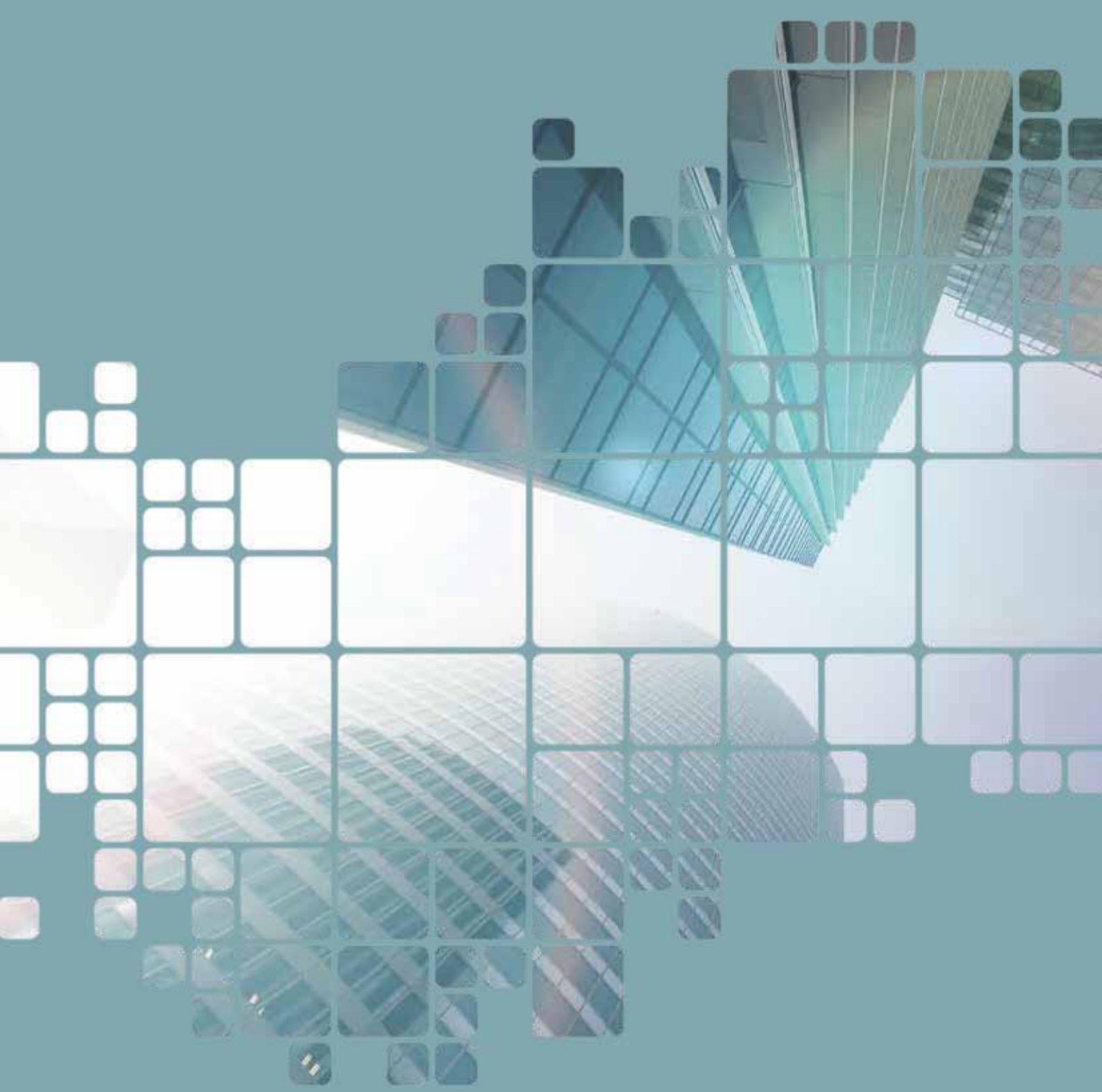

CHILLERS - HEAT PUMPS

Air cooled - Centrifugal fans

Low consumption Mini-Y C

TCCEY-THCEY 105÷111

Cooling capacity: 4.9÷10.6 kW - Heating capacity: 5÷10.8 kW



• Compact and Plug&Play units

Packaged reversible air-cooled heat pumps and water chillers with centrifugal fans.

Range with hermetic Scroll compressors and R410A refrigerant gas.

Construction features

- Compressor: hermetic, rotary scroll type, complete with thermal protection.
- Water side heat exchanger: adequately insulated stainless steel plate heat exchanger, complete with antifreeze heater and water flow differential pressure switch.
- Air side heat exchanger: featuring finned coil with copper pipes and aluminium fins, complete with protection grille.
- Fan: centrifugal electric fan with directly coupled motor, fitted with internal thermal protection and protection grilles.
- Control: microprocessor electronic control with Adaptive Function Plus logic.
- Structure: in galvanised and painted sheet steel, complete with condensation drain pan for THCEY.

Models

- TCCEY: unit designed for cooling only.
- THCEY: heat pump unit.

Factory fitted accessories

- Soft-start device (for models with 230V power supply).
- Condensation control -10°C .
- Low pressure switch.
- Compressor crankcase heater.
- Digital input for double set-point.
- 4-20 mA analogue input for shifting set-point.
- Water low set-point temperature.

Accessories separately supplied

- Rubber vibration dampers.
- -10°C condensation control
- Water filter.
- Low pressure switch.
- Antifreeze heater on the buffer tank.
- Inlet anti-vibration connection.
- Outlet anti-vibration connection.
- Outdoor air temperature probe for set-point compensation
- Additional electric heater for heat pump, managed by regulation.
- Remote keypad with display.
- Clock board.
- Interfaces for serial communication with other devices.
- RS485/USB serial converter.
- Rhoss supervisors for unit monitoring and remote management.



TCCEY-THCEY MODEL		105	107	109	111	
❶	TCCEY Nominal cooling capacity	kW	4,9	6	8,3	10,1/10,6
❶	TCCEY absorbed power	kW	1,98	2,49	3,47	4,28/4,33
❶	E.E.R. TCCEY		2,47	2,41	2,39	2,36/2,45
●	E.S.E.E.R. TCCEY		2,44	2,43	2,53	2,47/2,5
★	E.S.E.E.R.+		2,8	2,76	2,89	2,78 / 2,84
❷	Nominal heating capacity	kW	4,95	6,18	8,11	10,44/10,83
❷	Absorbed power	kW	2,02	2,43	3,51	4,11/4,4
❷	C.O.P.		2,45	2,54	2,31	2,54/2,46
THCEY MODEL SEASONAL PERFORMANCE IN HEATING MODE						
(∇)	Pdesign (EN 14825)	kW	5	6	8	10
(∇)	SCOP (EN 14825)		3,03	3,11	3,03	3,12
(§)	η_s	%	118	122	118	122
(§)	Energy class		A	A	A	A
❸	Sound pressure	dB(A)	47	48	50	51
	Scroll/step compressor	no.	1/1	1/1	1/1	1/1
	Circuits	no.	1	1	1	1
	Fan nominal air flow	m ³ /h	2450	2400	2650	2600
	Fan available static pressure	Pa	80	70	80	70
	Buffer tank water content	l	19	19	30	30
❹	Circulator available head	kPa	60	60	87	79
	Electrical supply	V-ph-Hz	230-1-50	230-1-50 / 400-3+N-50	230-1-50 / 400-3+N-50	230-1-50 / 400-3+N-50
DIMENSIONS AND WEIGHTS			105	107	109	111
	L - Width	mm	990	990	990	990
	H - PUMP height	mm	940	940	1125	1125
	H - TANK & PUMP height	mm	940	940	1330	1330
	P - Depth	mm	630	630	630	630
❹	TCCEY weight	kg	143	145	164	178
❹	THCEY weight	kg	153	155	174	188

Data at the following conditions:

- ❶ Air: 35°C - Water: 12/7°C.
 - ❷ Air: 7°C D.B. - 6°C W.B. - Water: 40/45°C.
 - ❸ In open field (Q = 2) at 5 m from the unit.
 - ❹ Weight refers to most complete set up.
 - ESEER = (European seasonal EER) - Average European seasonal efficiency.
 - ★ ESEER with Adaptive Function Plus software. ESEER+ is not Eurovent certified.
- Performance according to EN 14511:2013
- (∇) In Average climatic conditions, low temperature application
- (§) Seasonal energy efficiency: low temperature application in Average climate (EU Regulations N°811/2013 and N°813/2013)

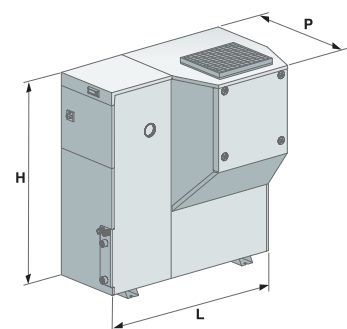

Low consumption Compact-Y C

TCCEY-THCEY 114÷128

Cooling capacity: 13.3÷26.6 kW - Heating capacity: 13.7÷29.2 kW



- Vertical or horizontal air discharge

Packaged reversible air-cooled heat pumps and water chillers with centrifugal fans.

Range with hermetic Scroll compressors and R410A refrigerant gas.

Construction features

- Compressor: hermetic, rotary scroll type, complete with thermal protection.
- Water side heat exchanger: adequately insulated stainless steel plate heat exchanger, complete with antifreeze heater and water flow differential pressure switch.
- Air side heat exchanger: featuring finned coil with copper pipes and aluminium fins, complete with protection grille.
- Fan: centrifugal electric fans with directly coupled motor, fitted with internal thermal protection and protection grilles.
- Vertical condensation air supply.
- Control: microprocessor electronic control with Adaptive Function Plus logic.
- Structure: peraluman, complete with condensation drain pan for THCEY.

Models

- TCCEY: unit designed for cooling only.
- THCEY: heat pump unit.

Factory fitted accessories

- Horizontal flow of condensation air.
- Antifreeze heater on the buffer tank.
- Condensation control -10°C .
- Compressor crankcase heater.
- Soft-start device.
- Silenced set up.
- Digital input for double set-point.
- 4-20 mA analogue input for shifting set-point.
- Water low set-point temperature.

Accessories supplied loose

- Rubber anti-vibration mountings.
- -10°C condensing control (models 114-126).
- Water filter.
- Inlet anti-vibration connection.
- Outlet anti-vibration connection.
- 3-way valve for the production of domestic hot water, managed by regulation.
- Outdoor air temperature probe for set-point compensation.
- Additional electric heater for heat pump, managed by regulation.
- Remote keyboard with display.
- Clock board.
- Interfaces for serial communication with other devices.
- Serial converter (RS485/USB).
- Rhoss supervisors for unit monitoring and remote management.



TCCEY-THCEY MODEL		114	117	121	126	128	
❶	Nominal cooling capacity	kW	13,3	15,9	20,1	23,2	26,6
❶	Absorbed power	kW	4,68	5,46	7,56	8,96	10,08
❶	E.E.R.		2,84	2,91	2,66	2,59	2,64
●	E.S.E.E.R.		3,1	3,09	2,97	2,81	2,84
★	E.S.E.E.R.+		3,13	3,21	3,09	3,08	3,06
❷	Nominal heating capacity	kW	13,7	17	21,6	25,6	29,2
❷	Absorbed power	kW	4,71	5,57	7,06	8,26	9,39
❷	C.O.P.		2,91	3,05	3,06	3,1	3,11
THCEY MODEL SEASONAL PERFORMANCE IN HEATING MODE							
(∅)	Pdesign (EN 14825)	kW	14	17	22	26	29
(∅)	SCOP (EN 14825)		3,12	3,33	3,09	3,25	3,05
(§)	ηs	%	122	130	121	127	119
(§)	Energy class		A	A+	A	A+	A
❸	Sound pressure	dB(A)	54	55	56	57	61
	Scroll/step compressor	no.	1/1	1/1	1/1	1/1	1/1
	Circuits	no.	1	1	1	1	1
	Fan nominal air flow	m³/h	6900	6900	7500	6800	8400
	Fan available static pressure	Pa	90	80	80	70	120
	Water buffer tank content (T&P set up)	l	55	55	80	80	80
❶	Available head pressure of the standard electric pump	kPa	50	44	157	151	131
❶	Available head pressure of high pressure pump	kPa	179	160	-	-	-
	Electrical supply	V-ph-Hz	400-3+N-50	400-3+N-50	400-3+N-50	400-3+N-50	400-3+N-50
DIMENSIONS AND WEIGHTS			114	117	121	126	128
	L - Width	mm	1320	1320	1710	1710	1710
	H - STANDARD height	mm	1305	1305	1305	1305	1305
	H - TANK & PUMP height	mm	1600	1600	1600	1600	1600
	P - Depth	mm	558	558	643	643	643
❹	TCCEY weight	kg	340	360	420	440	440
❹	THCEY weight	kg	350	370	440	460	460

Data at the following conditions:

- ❶ Air: 35°C - Water: 12/7°C.
- ❷ Air: 7°C D.B. - 6°C W.B. - 70% R.H. - Water: 40/45°C.
- ❸ At 5 m from the unit in free field (Q = 2), with ducted fans.
- ❹ Weight refers to most complete set up.
- ESEER = (European seasonal EER) - Average European seasonal efficiency.
- ★ ESEER with Adaptive Function Plus software. ESEER+ is not Eurovent certified.
Performance according to EN 14511:2013. Standard set up
- (∅) In Average climatic conditions, low temperature application
- (§) Seasonal energy efficiency: low temperature application in Average climate (EU Regulations N°811/2013 and N°813/2013)

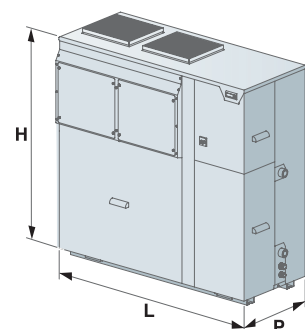

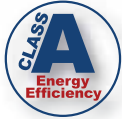

Low consumption Y-Pack C-PF

TCCEY-THCEY 233÷2160

Cooling capacity: 32.3÷160.2 kW - Heating capacity: 37.7÷175.6 kW



TCCEY 233

THCEY 2130

- High energy efficiency range
- “Plug-Fan” type of centrifugal fans with EC motor (brushless)
- 3 capacity steps

High efficiency packaged reversible air-cooled water chillers and heat pumps with Plug-Fan centrifugal fans with EC motors.

Range with hermetic Scroll compressors and R410A refrigerant.

Construction features

- Compressor: hermetic, rotary Scroll compressor, complete with thermal protection and casing heater.
- 2 or 3 capacity steps depending on the models that allows excellent load modulation together with high energy efficiency at partial loads to be achieved.
- Water side heat exchanger: with stainless steel plates, complete with closed cell polyurethane foam rubber insulation and water flow differential pressure switch.
- Air side heat exchanger: featuring finned coil with copper pipes and aluminium fins.
- Plug-Fan type of centrifugal electric fans with EC motors, equipped with internal thermal protection set in a single row with horizontal outlet. Horizontal condensation/evaporation air outlet opposite the finned coil or vertical can be easily transformed on site.
- Proportional electronic device for continuous fan rotation speed regulation down to an outdoor air temperature of -15°C in chiller mode, and up to an outdoor air temperature of 40°C in heat pump mode.
- Control: microprocessor electronic control with Adaptive Function Plus logic.
- Load-bearing structure and panelling made of galvanised and painted (RAL 9018) sheet steel; galvanised sheet steel base

Versions

- T - High efficiency version (TCCEY-THCEY).

Models

- TCCEY: unit for cooling only.
- THCEY: reversible heat pump unit.

Factory fitted accessories

- PUMP with single or double electric pump, including an automatic pump in standby, complete with expansion tank, safety valve and water side pressure gauge. The pumps are available in the low or high pressure versions.
- TANK&PUMP with built-in buffer tank and single or double pump, complete with expansion tank, air bleed valves, safety valve and water pressure gauge.
- Desuperheater.
- 100% Heat recovery unit
- Electronic expansion valve.
- Power factor correction capacitors ($\cos\phi > > 0.94$).
- Soft starter.
- Compressor soundproofing.
- Refrigerant circuit high and low pressure gauges.
- Copper/copper or copper/pre-painted aluminium coils.
- Digital input for double set-point.
- 4-20 mA analogue input for shifting set-point.
- Evaporator antifreeze resistance, buffer tank, pumps and heat exchangers for heat recovery if present.
- Interfaces for serial communication with other devices.
- Anti-vibration mountings.

Separately supplied accessories

- Remote keyboard with display.
- Clock board.
- Rhoss supervisors for unit monitoring and remote management.
- Rhoss sequencer for integrated management of several water chillers.





TCCEY MODEL		233	238	245	250	260	265	270	
❶	Nominal cooling capacity	kW	32,3	38,5	43,9	51,0	58,9	63,7	69,9
❶	E.E.R.		2,61	2,77	2,7	2,75	2,68	2,62	2,85
❶	Absorbed power	kW	12,38	13,9	16,26	18,55	21,98	24,31	24,53
●	E.S.E.E.R.		4,48	4,04	4,29	4,43	4,3	4,36	4,48
★	E.S.E.E.R.+		5,02	4,51	4,97	5,12	4,95	5,06	5,17
THCEY MODEL		233	238	245	250	260	265	270	
❷	Nominal heating capacity	kW	37,7	42,1	48,1	56,2	62,5	68,3	79,4
❷	C.O.P.		3	3	3,01	2,99	2,99	2,88	3,26
❷	Absorbed power in winter operation	kW	12,57	14,03	15,98	18,8	20,9	23,72	24,36
❶	Nominal cooling capacity	kW	32,3	38,5	42,3	50,3	57,8	61,6	69,1
THCEY MODEL SEASONAL PERFORMANCE IN HEATING MODE									
(∇)	Pdesign (EN 14825)	kW	31	35	42	48	53	60	66
(∇)	SCOP (EN 14825)		3,53	3,52	3,86	3,56	3,49	3,60	3,74
(§)	ηs	%	138	138	152	139	137	141	147
(§)	Energy class		A+	A+	A++	A+	A+	A+	A+
❸	Sound power	dB(A)	82	82	83	85	85	85	85
	Scroll/step compressor	no.	2/2	2/2	2/3	2/3	2/3	2/3	2/3
	Circuits	no.	1	1	1	1	1	1	1
	Fan nominal air flow	m³/h	13000	13000	13000	26000	26000	26000	26000
	Fan maximum available static pressure	Pa	250	250	250	250	250	250	250
	Electrical supply	V-ph-Hz	400-3+N-50	400-3+N-50	400-3+N-50	400-3+N-50	400-3+N-50	400-3+N-50	400-3+N-50
SIZES		233	238	245	250	260	265	270	
	L - Width	mm	2650	2650	2650	2650	2650	2650	3650
	H - Height	mm	1920	1920	1920	1920	1920	1920	1920
	P - Depth	mm	870	870	870	870	870	870	1100

TCCEY MODEL		280	290	2100	2115	2130	2145	2160	
❶	Nominal cooling capacity	kW	79,1	87,5	100,6	113,9	125,3	142,3	160,2
❶	E.E.R.		2,9	2,82	2,74	2,93	2,89	2,9	2,89
❶	Absorbed power	kW	27,28	31,03	36,72	38,87	43,36	49,07	55,43
●	E.S.E.E.R.		4,18	4,11	4,09	4,04	4,4	4,53	4,14
★	E.S.E.E.R.+		4,84	4,76	4,72	4,68	5,07	5,22	4,71
THCEY MODEL		280	290	2100	2115	2130	2145	2160	
❷	Nominal heating capacity	kW	86,3	96,4	111,5	122,5	139,6	157,6	175,6
❷	C.O.P.		3,38	3,2	3,19	3,25	3,33	3,25	3,24
❷	Absorbed power in winter operation	kW	25,53	30,13	34,95	37,69	41,92	48,49	54,2
❶	Nominal cooling capacity	kW	77,4	84,9	98,9	110,6	123,4	140,8	159,3
THCEY MODEL SEASONAL PERFORMANCE IN HEATING MODE									
(∇)	Pdesign (EN 14825)	kW	71	80	93	102	117	132	147
(∇)	SCOP (EN 14825)		4,16	3,69	3,63	3,72	4,10	3,69	3,99
(§)	ηs	%	163	144	142	146	161	145	156
❸	Sound power	dB(A)	85	86	88	88	88	89	89
	Scroll/step compressor	no.	2/2	2/3	2/3	2/3	2/2	2/3	2/2
	Circuits	no.	1	1	1	1	1	1	1
	Fan nominal air flow	m³/h	26000	27000	39000	39000	39000	52000	52000
	Fan maximum available static pressure	Pa	250	250	250	250	250	250	250
	Electrical supply	V-ph-Hz	400-3+N-50	400-3+N-50	400-3+N-50	400-3+N-50	400-3+N-50	400-3+N-50	400-3+N-50
SIZES		280	290	2100	2115	2130	2145	2160	
	L - Width	mm	3650	3650	3650	4450	4450	4450	4450
	H - Height	mm	1920	1920	1920	2320	2320	2320	2320
	P - Depth	mm	1100	1100	1100	1100	1100	1100	1100

Data at the following conditions:

- ❶ Air: 35°C - Water: 12/7°C and ESP: 250 Pa.
 - ❷ Air: 7°C D.B. - 6°C W.B. - Water: 40/45°C and ESP: 250 Pa.
 - ❸ Total sound power level in dB(A) on the basis of measurements taken in accordance with RS S/C/005-2009 and UNI EN-ISO 9614.
 - ESEER (European Seasonal EER) - Average European seasonal efficiency.
 - ★ ESEER with Adaptive Function Plus software. ESEER+ is not Eurovent certified.
- Performance according to EN 14511:2013
- (∇) In Average climatic conditions, low temperature application
- (§) Seasonal energy efficiency: low temperature application in Average climate (EU Regulations N°811/213 and N°813/2013)

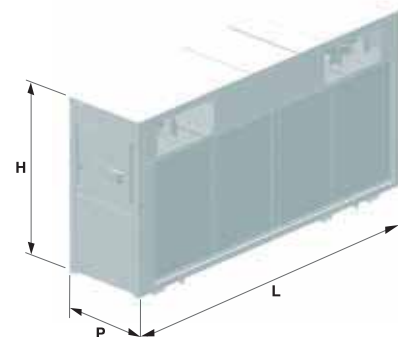

Low Consumption Comby-Flow - TCHEY-THHEY 105÷112

Low consumption Y-Flow - TCHEY-THHEY 115÷240

Low consumption Y-Flow - TCHEY-THHEY 245÷4450

Z-Flow HE - TCHVZ 1201÷31631

Z-Flow SE - TCHVZ 1200÷31630

Low consumption Y-Flow E - TCEEY 115÷240

Low consumption Y-Flow E - TCEEBY 245÷4360

Z-Flow E - TCEVZ 1200÷31630



CHILLERS - HEAT PUMPS

Water cooled - Condenserless

Low Consumption Comby-Flow

TCHEY-THHEY 105÷112

Cooling capacity: 5.5÷12.2 kW - Heating capacity: 6.6÷13.7 kW



- **ESEER with Adaptive Function Plus up to 4.5**
- **Extremely compact and silent units**

Packaged water-cooled water chillers and reversible heat pumps on the cooling circuit. Range with hermetic Scroll compressors and R410A refrigerant gas.

Construction features

- Compressor: hermetic, rotary scroll type, complete with thermal protection.
- Primary side (user) heat exchanger: suitably insulated stainless steel plates, complete with antifreeze heater and water flow differential pressure switch.
- Well/aqueduct side heat exchanger (disposal unit): with suitably insulated stainless steel plate heat exchanger, complete with antifreeze heater and water flow differential pressure switch (for THHEY).
- Control: microprocessor electronic control with Adaptive Function Plus logic.
- Structure: made of galvanised and painted sheet steel with polyester powder coating, complete with soundproofed compressor.

Models

- TCHEY: unit designed for cooling only.
- THHEY: heat pump unit.

Factory fitted accessories

- Pressure switch valve.
- Pressure switch valve and bypass solenoid valve (only THHEY).
- Water circuit heat pump (for TCHEY only).
- Digital input for double set-point.
- 4-20mA analogue input for shifting set-point.
- Water low set-point temperature.

Accessories supplied loose

- Buffer tank.
- Buffer tank connection pipes.
- Water filter.
- Rubber anti-vibration mountings.
- Antifreeze heater on the buffer tank.
- Low pressure switch.
- 3-way valve for the production of domestic hot water.
- Outdoor air temperature probe for set-point compensation.
- Additional electric heater for heat pump, managed by regulation.
- Remote keyboard with display.
- Clock board.
- Interfaces for serial communication with other devices.
- Serial converter (RS485/USB).
- Rhoss supervisors for unit monitoring and remote management.



TCHEY-THHEY MODEL		105	107	109	112
Radiant systems					
① Heating capacity	kW	7,5	9,7	12,7	15
① Absorbed power	kW	1,6	2,1	2,72	3,33
① C.O.P.		4,68	4,61	4,67	4,51
② Heating capacity (geothermal)	kW	5,4	7,3	9,4	11,3
② Absorbed power (geothermal)	kW	1,5	2,15	2,78	3,34
② C.O.P. (geothermal)		3,62	3,39	3,38	3,39
③ TCHEY cooling capacity	kW	7,6	10,4	13,5	17,6
③ TCHEY absorbed power	kW	1,56	2,22	2,84	3,86
③ E.E.R. TCHEY		4,86	4,69	4,76	4,56
Fan coil systems					
④ Heating capacity	kW	6,58	8,1	10,63	13,71
④ Absorbed power	kW	2,08	2,8	3,33	4,21
④ C.O.P.		3,17	2,89	3,19	3,26
⑤ TCHEY cooling capacity	kW	5,5	6,8	9,2	12,2
⑤ TCHEY absorbed power	kW	1,69	2,19	2,79	3,74
⑤ E.E.R. TCHEY		3,25	3,11	3,3	3,26
● E.S.E.E.R. TCHEY		3,43	3,65	3,91	3,87
★ E.S.E.E.R.+		4	4,25	4,46	4,34
THHEY MODEL SEASONAL PERFORMANCE IN HEATING MODE					
(∅) Pdesign (EN 14825)	kW	9	12	16	19
(∅) SCOP (EN 14825)		5,39	5,57	5,55	5,18
(§) η_s	%	208	215	214	199
(§) Energy class		A++	A++	A++	A++
⑥ Sound pressure	dB(A)	49	51	51	53
Scroll/step compressor	no.	1/1	1/1	1/1	1/1
KA Buffer tank water content	l	20	20	30	30
⑤ Circulator available head	kPa	47	55	82	77
Electrical supply	V-ph-Hz	230-1-50	230-1-50 / 400-3+N-50	230-1-50 / 400-3+N-50	230-1-50 / 400-3+N-50
DIMENSIONS AND WEIGHTS		105	107	109	112
L - Width	mm	585	585	660	660
H - STANDARD - PUMP height	mm	535	535	535	535
H - STANDARD - PUMP + KA height	mm	855	855	855	855
P - Depth	mm	386	386	420	420
⑦ Weight	kg	78	83	94	97
KA Weight	kg	28	28	33	33

Data at the following conditions:

- ① Hot water: 30/35°C - Evaporator water: 10/7°C.
- ② Hot water: 30/35°C - Evaporator water: 0/-3°C, 30% glycol.
- ③ Chilled water: 23/18°C - Condenser water: 30/35°C.
- ④ Hot water: 40/45°C - Evaporator water: 10/7°C.
- ⑤ Chilled water: 12/7°C - Condenser water: 30/35°C.
- ⑥ In open field (Q = 2) at 1 m from the unit.
- ⑦ Weight refers to most complete set up.
- ESEER = (European seasonal EER) - Average European seasonal efficiency.
- ★ ESEER with Adaptive Function Plus software. ESEER+ is not Eurovent certified.

Performance according to EN 14511:2013. Standard set up

KA = buffer tank.

KTC = connecting pipe.

(∅) In Average climatic conditions, low temperature application

(§) Seasonal energy efficiency: low temperature application in Average climate (EU Regulations N°811/213 and N°813/2013)

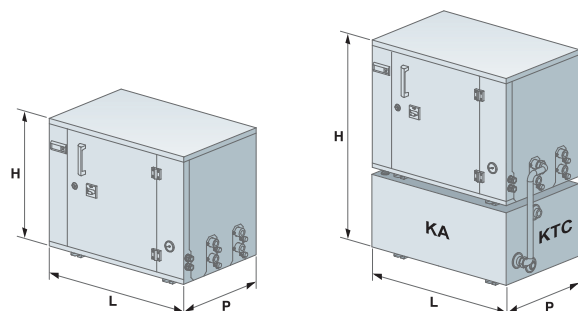

Low consumption Y-Flow

TCHEY-THHEY 115÷240

Cooling capacity: 15.5÷41.7 kW - Heating capacity: 17.4÷45.1 kW



- **CLASS A unit (radiant applications)**
- **Applications with ground water or city water or geothermal probes.**
- **Plug&Play unit with hydraulic connections on the top**

Packaged water-cooled water chillers and reversible heat pumps on the cooling circuit. Range with hermetic Scroll compressors and R410A refrigerant gas.

Construction features

- Compressor: hermetic rotary scroll complete with thermal protection and crankcase heater.
- Primary side (user) heat exchanger: suitably insulated stainless steel plates, complete with antifreeze heater and water flow differential pressure switch.
- Disposal unit side heat exchanger (well/aqueduct/geothermal probes): suitably insulated stainless steel plates, complete with antifreeze heater and water flow differential pressure switch (for THHEY).
- Control: microprocessor electronic control with Adaptive Function Plus logic.
- Structure: made of galvanised and painted steel plate with polyester powder coating, internally covered with soundproof panelling.

Models

- TCHEY: unit designed for cooling only.
- THHEY: heat pump unit.

Factory fitted accessories

- PUMP:
 - Primary side (user): pump unit complete with electric circulation pump with standard or increased head pressure, membrane expansion tank, safety valve, water fill/drain valve, manual air vent valve and pressure gauge.
 - Disposal side (geothermal probes/dry cooler): pump unit complete with phase cutting electric pump, water fill/drain valve and manual air vent valve.
- Silenced set up.
- Pressure switch valve with water flow lock solenoid.
- Pressure switch valve with water flow lock solenoid and bypass solenoid valve.
- Water circuit heat pump (for TCHEY only).
- Soft-start device.
- Water low set-point temperature.
- Digital input for double set-point.
- 4-20mA analogue input for shifting set-point.

Accessories supplied loose

- 3-way valve for the production of domestic hot water.
- Additional electric heater for heat pump, managed by regulation.
- Outdoor air temperature probe for set-point compensation.
- Free-cooling kit.
- Water filter.
- Rubber anti-vibration mountings.
- Remote keyboard with display.
- Clock board.
- Interfaces for serial communication with other devices.
- Serial converter (RS485/USB).
- Rhoss supervisors for unit monitoring and remote management.



TCHEY-THHEY MODEL		115	118	122	125	230	240	
Radiant systems								
①	THHEY heating capacity	kW	18,6	21,5	26,6	30,7	47,9	
①	Absorbed power	kW	3,29	3,55	4,45	5,04	8,09	
①	C.O.P.		5,66	6,05	5,97	6,09	5,92	
②	THHEY heating capacity (geothermal)	kW	13,4	15,3	18,6	21,7	33,8	
②	C.O.P. (geothermal)		4,12	4,21	4,37	4,49	4,3	
③	TCHEY cooling capacity	kW	22,1	25,7	31,6	36,5	58,8	
③	TCHEY absorbed power	kW	3,46	3,71	4,83	5,45	8,78	
③	E.E.R. TCHEY		6,38	6,92	6,54	6,7	6,18	
Fan coil systems								
④	THHEY heating capacity	kW	17,4	20,2	25,1	28,9	45,1	
④	Absorbed power	kW	3,95	4,41	5,59	6,3	10,11	
④	C.O.P.		4,4	4,58	4,49	4,59	4,46	
⑤	TCHEY/THHEY cooling capacity	kW	15,5/13,9	18,4/16,3	22,7/20	26,3/23,1	30,5/27,3	41,7/35,9
⑤	TCHEY absorbed power	kW	3,27	3,49	4,5	5,01	6,64	8,07
⑤	E.E.R. TCHEY		4,74	5,27	5,04	5,25	4,59	5,17
●	E.S.E.E.R. TCHEY		5,52	5,96	5,9	5,97	5,18	5,81
★	E.S.E.E.R.+		6,28	6,8	6,77	6,83	6,17	6,91
THHEY MODEL SEASONAL PERFORMANCE IN HEATING MODE								
(∅)	Pdesign (EN 14825)	kW	23	27	33	38	48	59
(∅)	SCOP (EN 14825)		6,10	6,43	6,44	6,54	6,6	6,74
(§)	η_s	%	236	249	250	254	256	262
(§)	Energy class		A++	A++	A++	A++	A++	A++
⑥	Sound pressure	dB(A)	42	42	46	47	48	52
	Scroll/step compressor	no.	1/1	1/1	1/1	1/1	2/2	2/2
	Circuits	no.	1	1	1	1	1	1
⑤	Std system side electric pump available head pressure	kPa	88	81	73	113	105	115
	Electrical supply	V-ph-Hz	400-3+N-50	400-3+N-50	400-3+N-50	400-3+N-50	400-3+N-50	400-3+N-50
DIMENSIONS AND WEIGHTS			115	118	122	125	230	240
L - Width	mm		700	700	700	700	700	700
H - STANDARD - PUMP height	mm		1140	1140	1140	1140	1140	1140
P - Depth	mm		560	560	780	780	780	780
⑦	Weight	kg	193	193	230	254	278	298

Data at the following conditions:

- ① Hot water: 30/35°C - Evaporator water: 10/7°C.
- ② Hot water: 30/35°C - Evaporator water: 0/-3°C, 30% glycol.
- ③ Chilled water: 23/18°C - Condenser water: 30/35°C.
- ④ Hot water: 40/45°C - Evaporator water: 10/7°C.
- ⑤ Chilled water: 12/7°C - Condenser water: 30/35°C.
- ⑥ In open field (Q = 2) at 1 m from the unit, with silenced set up.
- ⑦ Weight refers to most complete set up.
- ESEER = (European seasonal EER) - Average European seasonal efficiency.
- ★ ESEER with Adaptive Function Plus software. ESEER+ is not Eurovent certified.
Performance according to EN 14511:2013.
- (∅) In Average climatic conditions, low temperature application
- (§) Seasonal energy efficiency: low temperature application in Average climate (EU Regulations N°811/2013 and N°813/2013)



Low consumption Y-Flow TCHEY-THHEY 245÷4450

Cooling capacity: 41.2÷448.8 kW - Heating capacity: 50.23÷515.49 kW



THHEY 4260

TCHEY 2100

- Class A unit (radiant applications)
- Applications with well water, water mains or geothermal probes
- Vast range of set ups and accessories
- Version HT65 for water production 65°C (°)

Packaged water-cooled water chillers and reversible heat pumps on the cooling circuit. Range with hermetic Scroll compressors and R410A refrigerant gas.

Construction features

- Compressor: hermetic, rotary Scroll compressor, complete with thermal protection and casing heater.
- Primary side (user) heat exchanger: suitably insulated stainless steel plates, complete with antifreeze heater and water flow differential pressure switch.
- Drain side heat exchanger (ground/aqueduct/geothermal probes): suitably insulated stainless steel plates, complete with antifreeze heater and water flow differential pressure switch (for THHEY).
- Control: microprocessor electronic control with Adaptive Function Plus logic.
- Structure: made of galvanised and painted sheet steel, with polyester powder coating.

Versions

- LT - Hot water production up to 52°C.
- HT - Hot water production up to 55°C.

Models

- TCHEY: unit designed for cooling only.
- THHEY: heat pump unit.

Factory fitted accessories

- PUMP Primary side (user): with single or double pump, including an automatic pump in standby, complete with expansion tank, safety valve, water charge/drain valve, air bleed valve, pressure gauge. The electric pumps are available in the low or high pressure head versions. →
- PUMP Disposal unit side PUMP (geothermal probes/dry cooler): with single or double electric pump regulated via inverter including one in standby and with automatic activation. →

- Desuperheater. →
- Heat recovery unit 100% (mod. 245÷4360). →
- Water circuit heat pump (for TCHEY only).
- Power factor correction capacitors.
- Soft-start device.
- Forced limit of power consumption.
- Electronic expansion valve (standard for mod. 4410-4450).
- Refrigerant circuit high and low pressure gauges.
- Silenced set up.
- Water low set-point temperature.
- Digital input for double set-point.
- 0-10V analogue input for condensation control performed by external device.
- 4-20mA analogue input for shifting set-point.
- Interfaces for serial communication with other devices.
- Rubber anti-vibration mountings.

Accessories supplied loose

- Modulating 3-way valve for condensing control.
- Modulating 2-way valve for condensing control.
- Outdoor air temperature probe for set-point compensation.
- Free-cooling kit (mod. 245-2185).
- Water filter.
- Remote keyboard with display.
- Clock board.
- Serial converter (RS485/USB).
- Rhoss supervisors for unit monitoring and remote management.
- Rhoss sequencer for integrated management of several water chillers.

(°) Review the specific documentation to verify the available models and accessories.

→ The units can be equipped with up to 2 pumps in mod. 245÷2185 and 4 electric pumps in mod. 4180-4450. In the presence of recovery unit or desuperheater, the PUMP configuration is not provided.



TCHEY MODEL		245	250	260	270	275	290	2100	2115	2130	2145	2165	2185
❶ Cooling capacity	kW	45	53	60,3	68,9	75,5	89,6	102,6	116,8	130,5	145,1	164,9	184
❶ Absorbed power	kW	9,85	11,42	13,19	15,01	16,52	19,27	22,55	25,55	29	31,82	37,06	42,01
❶ E.E.R.		4,57	4,64	4,57	4,59	4,57	4,65	4,55	4,56	4,5	4,56	4,45	4,38
● E.S.E.E.R.		6,6	6,6	6,64	6,39	6,5	6,26	6,07	6,17	6,04	6,02	6,02	5,79
★ E.S.E.E.R.+		7,54	7,62	7,68	7,39	7,42	7,23	7,1	7,08	6,91	6,89	6,91	6,71
MODEL THHEY		245	250	260	270	275	290	2100	2115	2130	2145	2165	2185
❷ Heating capacity	kW	50,2	59,1	67,9	75,7	84,1	102,4	117,0	133,9	147,9	163,4	186,9	209,7
❷ C.O.P.		4,1	4,22	4,25	4,27	4,22	4,26	4,2	4,24	4,17	4,13	4,07	4,01
❶ Cooling capacity		41,2	48,5	55,2	63	69,1	81,9	95,7	109,1	120,7	134,3	152,2	169,9
❷ Absorbed power	kW	12,24	14	15,98	17,73	19,93	24,04	27,86	31,58	35,47	39,56	45,92	52,29
THHEY MODEL SEASONAL PERFORMANCE IN HEATING MODE													
(∅) Pdesign (EN 14825)	kW	61	71	81	91	101	122	140	159	174	196	224	250
(∅) SCOP (EN 14825)		6,48	6,54	6,43	6,41	6,69	6,33	6,38	6,35	6,14	6,05	6,14	5,85
(S) ηs	%	251	254	249	249	260	245	247	246	237	234	237	226
(S) Energy class		A++	-	-	-	-	-	-	-	-	-	-	-
❸ Sound power	dB(A)	67	67	68	68	69	70	71	72	73	74	74	75
Scroll/step compressor	no.	2/2	2/2	2/2	2/2	2/3	2/2	2/3	2/3	2/3	2/2	2/3	2/2
Circuits	no.	1	1	1	1	1	1	1	1	1	1	1	1
Electrical supply	V-ph-Hz	400-3+N-50	400-3+N-50	400-3+N-50	400-3+N-50	400-3+N-50	400-3+N-50	400-3+N-50	400-3+N-50	400-3+N-50	400-3+N-50	400-3+N-50	400-3+N-50
DIMENSIONS AND WEIGHTS		245	250	260	270	275	290	2100	2115	2130	2145	2165	2185
❹ L - Width	mm	1020	1020	1020	1020	1020	1020	1270	1270	1270	1270	1270	1270
❺ L - Width	mm	1250	1250	1250	1250	1250	1250	1500	1500	1500	1500	1500	1500
H - Height	mm	1470	1470	1470	1470	1470	1470	1620	1620	1620	1620	1620	1620
P - Depth	mm	870	870	870	870	870	870	870	870	870	870	870	870
❻ Weight TCHEY LT	kg	395	405	410	425	420	450	695	710	730	755	770	775
❻ Weight TCHEY HT	kg	425	430	440	460	455	480	740	770	800	825	850	855
❻ Weight THHEY LT	kg	405	415	425	440	435	460	700	720	750	755	790	800
❻ Weight THHEY HT	kg	435	445	455	470	465	495	755	790	820	845	870	880

TCHEY MODEL		4180	4205	4235	4260	4290	4330	4360	4410	4450
❶ Cooling capacity	kW	180,6	206,5	232,2	259,8	287,2	325,6	362,8	407,1	448,8
❶ Absorbed power	kW	37,78	43,2	48,58	54,58	60,46	69,72	79,39	90,87	103,17
❶ E.E.R.		4,78	4,78	4,78	4,76	4,75	4,67	4,57	4,48	4,35
● E.S.E.E.R.		5,82	5,95	6,11	6,1	6,09	6,01	5,87	5,64	5,28
★ E.S.E.E.R.+		6,78	7,03	7,19	7,12	7,13	7,07	6,94	6,63	6,16
MODEL THHEY		4180	4205	4235	4260	4290	4330	4360	4410	4450
❷ Heating capacity	kW	202,2	231	259,2	292,3	323,9	369,3	414	464,4	515,5
❷ C.O.P.		4,4	4,33	4,26	4,27	4,27	4,2	4,16	3,97	4,03
❶ Cooling capacity		160,4	183,5	206,5	231,4	255,2	292,7	330,1	373,9	412,9
❷ Absorbed power	kW	45,95	53,35	60,85	68,45	75,85	87,93	99,52	116,98	127,92
THHEY MODEL SEASONAL PERFORMANCE IN HEATING MODE										
(∅) Pdesign (EN 14825)	kW	262	302	340	383	-	-	-	-	-
(∅) SCOP (EN 14825)		6,88	6,64	6,49	6,48	-	-	-	-	-
(S) ηs	%	267	258	252	251	-	-	-	-	-
❸ Sound power	dB(A)	77	77	78	79	80	81	82	83	84
Scroll/step compressor	no.	4/4	4/4	4/4	4/4	4/4	4/4	4/4	4/4	4/4
Circuits	no.	2	2	2	2	2	2	2	2	2
Electrical supply	V-ph-Hz	400-3+N-50	400-3+N-50	400-3+N-50	400-3+N-50	400-3+N-50	400-3+N-50	400-3+N-50	400-3+N-50	400-3+N-50
DIMENSIONS AND WEIGHTS		4180	4205	4235	4260	4290	4330	4360	4410	4450
❹ L - Width	mm	2600	2600	2600	2600	2600	2600	2600	2600	2600
❺ L - Width	mm	3734	3734	3734	3734	3734	3734	3734	3734	3734
H - Height	mm	1860	1860	1860	1860	1860	1860	1860	1860	1860
P - Depth	mm	870	870	870	870	870	870	870	870	870
❻ Weight TCHEY LT	kg	1350	1410	1440	1460	1500	1530	1570	1720	1750
❻ Weight TCHEY HT	kg	1440	1470	1510	1540	1600	1650	1680	1750	1790
❻ Weight THHEY LT	kg	1380	1440	1470	1500	1530	1560	1600	1750	1780
❻ Weight THHEY HT	kg	1470	1500	1550	1570	1630	1680	1720	1790	1820

Data at the following conditions:

- ❶ Chilled water: 12/7°C. - Condenser water: 30/35°C.
 - ❷ Hot water: 40/45°C. - Evaporator water: 10/7°C.
 - ❸ Total sound power level in dB(A) based on measurements carried out in accordance with regulation UNI EN-ISO 9614.
 - ❹ Width referring to the unit with standard set up or supplied with "recovery" or "desuperheater" accessories.
 - ❺ Width referring to the PUMP set up, up to a maximum of 2 pumps in mod. 245÷2185 (2 user side or disposal unit side pumps or 1 user side pump + 1 disposal unit side pump) and up to a maximum of 4 pumps in mod. 4180÷4450 (2 pumps on user side and 2 pumps on disposal unit side).
 - ❻ Empty weight
 - ESEER = (European seasonal EER) - Average European seasonal efficiency.
 - ★ ESEER with Adaptive Function Plus software. ESEER+ is not Eurovent certified.
- Performance according to EN 14511:2013
- (∅) In Average climatic conditions, low temperature application
 - (S) Seasonal energy efficiency: low temperature application in Average climate (EU Regulations N°811/2013 and N°813/2013)

Z-Flow HE

TCHVZ 1201÷31631

Cooling capacity: 203.3÷1,627.6 kW



TCHVBZ 31631 HE

- Efficiency range with ESEER at 5.88
- 33 sizes up to more than 1,600 kW
- Wide range of standard equipment
- Built-in MASTER/SLAVE management

Packaged water-cooled water chillers.
Range with semi-hermetic screw compressors and R134a refrigerant gas.

Construction features

- Compressor: high energy efficiency semi-hermetic screw compressor, with star-delta or part-winding limited start up (depending on models) and complete with integral protection, casing heater and refrigerant gas outlet piping shut-off valve.
- Electronic expansion valve: as standard on all models.
- Water side heat exchanger (evaporator): dry expansion shell and tube exchanger with counterflow heat exchange, complete with closed cell polyurethane rubber foam insulation, water flow differential pressure switch and Victaulic fittings.
- Water side heat exchanger (condenser): shell and tube complete with safety valve, and service valve on the high-pressure refrigerant circuit.
- Control: microprocessor electronic control.
- Structure: made of galvanised and painted steel plate with polyester powder coating.
- The unit is also complete with:
 - clock board;
 - display of cooling circuit high/low pressure;
 - Master/Slave control up to 4 units in parallel;
 - 0-10V analogue input for condensing control performed by external device.

Versions

- B - Standard version (TCHVBZ).
- I - Soundproofed version with soundproofed compressor cover (TCHVIZ).

Models

- TCHVBZ: unit designed for cooling only.
- TCHVIZ: soundproofed unit designed for cooling only.

Factory fitted accessories

- VPF management.
- Desuperheater.
- 100% Heat recovery unit
- Thermostat with display for heat recovery unit/desuperheater.
- Set up for heat pump operation.
- Condenser Victaulic connections.
- Power factor correction capacitors ($\cos\phi > 0.94$).
- Circuit breaker switches.
- Forced limit of power consumption.
- Soft starter.
- Inlet compressor shut-off valves
- Linear capacity control compressors (50-100 % for each compressor).
- Evaporator antifreeze heater.
- Digital input for double set-point
- Compressor oil level sensor.
- Control of min/max power supply voltage.
- 4-20 mA analogue input for shifting set-point.
- Interfaces for serial communication with other devices.
- Spring anti-vibration mounts.
- Rubber anti-vibration mounts.

Separately supplied accessories

- Remote keyboard with display.
- Rhoss supervisors for unit monitoring and remote management.
- Rhoss sequencer for integrated management of several water chillers.





TCHVBZ-TCHVIZ MODEL		1201	1231	1281	1311	1351	1421	1481	1531	1611	
❶	Nominal cooling capacity	kW	203.3	230.2	282.1	308.0	352.8	416.4	478.2	533.0	605.9
❶	E.E.R.		4.95	4.96	4.97	4.96	4.95	4.93	4.94	4.94	4.95
●	E.S.E.E.R.		5.88	5.71	5.72	5.63	5.82	5.77	5.64	5.6	5.85
❶	Absorbed power	kW	41.07	46.41	56.76	62.1	71.27	84.46	96.8	107.89	122.4
❸	Sound power	dB(A)	94	94	97	97	97	97	97	98	98
❸	Sound power	dB(A)	92	92	95	95	95	95	95	96	96
	Screw/step compressor	no.	1/3	1/3	1/3	1/3	1/3	1/3	1/3	1/3	1/3
	Circuits	no.	1	1	1	1	1	1	1	1	1
	Electrical supply	V-ph-Hz	400-3-50	400-3-50	400-3-50	400-3-50	400-3-50	400-3-50	400-3-50	400-3-50	400-3-50
DIMENSIONS AND WEIGHTS			1201	1231	1281	1311	1351	1421	1481	1531	1611
	L - Width	mm	3.460	3.460	3.440	3.440	3.450	3.450	3.450	3.450	3.450
	H - Height	mm	1.460	1.460	1.460	1.460	1.640	1.640	1.640	1.740	1.740
	P - Depth	mm	1.000	1.000	1.000	1.000	1.000	1.000	1.000	1.000	1.000
❺	TCHVBZ weight	kg	1.343	1.369	1.715	1.733	1.885	2.374	2.413	2.662	2.697
❺	TCHVIZ weight	kg	1.598	1.624	1.970	1.988	2.140	2.629	2.668	2.917	2.952

TCHVBZ-TCHVIZ MODEL		2411	2431	2461	2511	2561	2601	2631	2681	2711	
❶	Nominal cooling capacity	kW	405.5	433.6	460.4	512.7	563.3	596.9	626.6	674.8	712.5
❶	E.E.R.		4.95	4.96	4.95	4.97	4.97	4.96	4.95	4.98	4.94
●	E.S.E.E.R.		5.75	5.67	5.65	5.73	5.81	5.77	5.74	5.72	5.64
❶	Absorbed power	kW	81.92	87.42	93.01	103.16	113.34	120.34	126.59	135.5	144.23
❸	Sound power	dB(A)	97	97	97	99	99	99	99	99	99
❸	Sound power	dB(A)	95	95	95	97	97	97	97	97	97
	Screw/step compressor	no.	2/6	2/6	2/6	2/6	2/6	2/6	2/6	2/6	2/6
	Circuits	no.	2	2	2	2	2	2	2	2	2
	Electrical supply	V-ph-Hz	400-3-50	400-3-50	400-3-50	400-3-50	400-3-50	400-3-50	400-3-50	400-3-50	400-3-50
DIMENSIONS AND WEIGHTS			2411	2431	2461	2511	2561	2601	2631	2681	2711
	L - Width	mm	3.880	3.880	4.000	4.070	4.070	4.070	4.070	4.070	4.070
	H - Height	mm	1.840	1.840	1.840	1.960	1.960	1.960	1.960	1.960	1.960
	P - Depth	mm	1.300	1.300	1.300	1.300	1.300	1.300	1.300	1.300	1.300
❺	TCHVBZ weight	kg	2.386	2.413	2.458	2.953	3.297	3.320	3.337	3.404	3.447
❺	TCHVIZ weight	kg	2.816	2.843	2.888	3.383	3.727	3.750	3.767	3.834	3.877

TCHVBZ-TCHVIZ MODEL		2781	2841	2901	2961	21031	21111	21181	21261	
❶	Nominal cooling capacity	kW	774.9	835.2	898.0	954.5	1026.1	1105.5	1176.7	1253.1
❶	E.E.R.		4.94	4.92	4.95	4.94	4.98	5.06	5.08	5.08
●	E.S.E.E.R.		5.63	5.65	5.79	5.75	5.8	5.84	5.74	5.73
❶	Absorbed power	kW	156.86	169.76	181.41	193.22	206.04	218.48	231.63	246.67
❸	Sound power	dB(A)	99	99	99	99	99	99	99	99
❸	Sound power	dB(A)	97	97	97	97	97	97	97	97
	Screw/step compressor	no.	2/6	2/6	2/6	2/6	2/6	2/6	2/6	2/6
	Circuits	no.	2	2	2	2	2	2	2	2
	Electrical supply	V-ph-Hz	400-3-50	400-3-50	400-3-50	400-3-50	400-3-50	400-3-50	400-3-50	400-3-50
DIMENSIONS AND WEIGHTS			2781	2841	2901	2961	21031	21111	21181	21261
	L - Width	mm	4.120	4.000	4.000	4.000	4.000	4.000	4.000	4.000
	H - Height	mm	1.840	1.840	1.910	1.910	1.950	1.950	1.950	1.950
	P - Depth	mm	1.300	1.300	1.300	1.300	1.300	1.300	1.300	1.300
❺	TCHVBZ weight	kg	3.920	4.406	4.636	4.669	4.779	4.870	4.908	4.934
❺	TCHVIZ weight	kg	4.350	4.836	5.066	5.099	5.209	5.300	5.438	5.364

TCHVBZ-TCHVIZ MODEL		31301	31351	31401	31461	31521	31591	31631	
❶	Nominal cooling capacity	kW	1303.6	1351.2	1400.8	1457.3	1517.8	1576.2	1627.6
❶	E.E.R.		5.09	5.04	5.0	4.98	4.98	4.99	4.97
●	E.S.E.E.R.		5.82	5.77	5.81	5.76	5.87	5.86	5.86
❶	Absorbed power	kW	256.11	268.1	280.16	292.63	304.78	315.87	327.48
❸	Sound power	dB(A)	101	101	101	102	102	102	102
❸	Sound power	dB(A)	99	99	99	100	100	100	100
	Screw/step compressor	no.	3/9	3/9	3/9	3/9	3/9	3/9	3/9
	Circuits	no.	3	3	3	3	3	3	3
	Electrical supply	V-ph-Hz	400-3-50	400-3-50	400-3-50	400-3-50	400-3-50	400-3-50	400-3-50
DIMENSIONS AND WEIGHTS			31301	31351	31401	31461	31521	31591	31631
	L - Width	mm	4.940	4.940	4.940	4.940	4.940	4.940	4.940
	H - Height	mm	2.220	2.220	2.220	2.220	2.220	2.220	2.220
	P - Depth	mm	1.700	1.700	1.700	1.700	1.700	1.700	1.700
❺	TCHVBZ weight	kg	6.795	6.827	6.852	6.891	6.980	7.068	7.157
❺	TCHVIZ weight	kg	7.395	7.427	7.452	7.491	7.580	7.668	7.757

Data at the following conditions:

- ❶ Chilled water: 7/12°C. - Condenser input water: 30/35°C.
- ❸ Total sound power level in dB(A) based on measurements carried out in accordance with regulation UNI EN-ISO 9614.
- ❺ Empty weight.
- ESEER = (European seasonal EER) - Average European seasonal efficiency.
- TCHVIZ soundproofed version.

Performance according to EN 14511:2013

Z-Flow SE

TCHVZ 1200÷31630

Cooling capacity: 198.8÷1,624.5 kW



TCHVBZ 2710

- Efficiency range with EER >4.70
- 33 sizes up to more than 1,600 kW
- Heat pump set up with water production up to 55°C
- Built-in MASTER/SLAVE management

Packaged water-cooled water chillers.
Range with semi-hermetic screw compressors and R134a refrigerant gas.

Construction features

- Compressor: high energy efficiency semi-hermetic screw compressor, with star-delta or part-winding limited start up (depending on models) and complete with integral protection, casing heater and refrigerant gas outlet piping shut-off valve.
- Electronic expansion valve: as standard on all models.
- Water side heat exchanger (evaporator): dry expansion shell and tube exchanger with counterflow heat exchange, complete with closed cell polyurethane rubber foam insulation, water flow differential pressure switch and Victaulic fittings.
- Water side heat exchanger (condenser): shell and tube complete with safety valve, and service valve on the high-pressure refrigerant circuit.
- Control: microprocessor electronic control.
- Structure: made of galvanised and painted steel plate with polyester powder coating.
- The unit is also complete with:
 - clock board;
 - display of cooling circuit high/low pressure;
 - Master/Slave control up to 4 units in parallel;
 - 0-10V analogue input for condensing control performed by external device.

Versions

- B - Standard version (TCHVBZ).
- I - Soundproofed version with soundproofed compressor cover (TCHVIZ).

Models

- TCHVBZ: unit designed for cooling only.
- TCHVIZ: soundproofed unit designed for cooling only.

Factory fitted accessories

- VPF management.
- Desuperheater.
- 100% Heat recovery unit
- Thermostat with display for heat recovery unit/desuperheater.
- Set up for heat pump operation.
- Condenser Victaulic connections.
- Power factor correction capacitors ($\cos\phi > 0.94$).
- Circuit breaker switches.
- Forced limit of power consumption.
- Soft starter.
- Inlet compressor shut-off valves
- Linear capacity control compressors (50-100 % for each compressor).
- Evaporator antifreeze heater.
- Digital input for double set-point
- Compressor oil level sensor.
- Control of min/max power supply voltage.
- 4-20 mA analogue input for shifting set-point.
- Interfaces for serial communication with other devices.
- Spring anti-vibration mounts.
- Rubber anti-vibration mounts.

Separately supplied accessories

- Remote keyboard with display.
- Rhoss supervisors for unit monitoring and remote management.
- Rhoss sequencer for integrated management of several water chillers.



TCHVBZ-TCHVIZ MODEL		1200	1230	1280	1310	1350	1410	1460	1530	1590
❶	Nominal cooling capacity	kW	198.8	225.4	276.2	304.6	346.1	402.7	460.5	527.7
❶	E.E.R.		4.81	4.8	4.79	4.76	4.8	4.79	4.79	4.81
●	E.S.E.E.R.		5.73	5.55	5.5	5.46	5.73	5.65	5.52	5.49
❶	Absorbed power	kW	41.33	46.96	57.66	63.99	72.1	84.07	96.14	109.35
❸	Sound power	dB(A)	94	94	97	97	97	97	97	98
❸	Sound power	dB(A)	92	92	95	95	95	95	95	96
	Screw/step compressor	no.	1/3	1/3	1/3	1/3	1/3	1/3	1/3	1/3
	Circuits	no.	1	1	1	1	1	1	1	1
	Electrical supply	V-ph-Hz	400-3-50	400-3-50	400-3-50	400-3-50	400-3-50	400-3-50	400-3-50	400-3-50
DIMENSIONS AND WEIGHTS			1200	1230	1280	1310	1350	1410	1460	1530
	L - Width	mm	3.460	3.460	3.440	3.440	3.450	3.450	3.450	3.450
	H - Height	mm	1.460	1.460	1.460	1.460	1.640	1.640	1.640	1.740
	P - Depth	mm	1.000	1.000	1.000	1.000	1.000	1.000	1.000	1.000
❺	TCHVBZ weight	kg	1.333	1.359	1.695	1.713	1.865	2.354	2.393	2.642
❺	TCHVIZ weight	kg	1.588	1.614	1.950	1.968	2.120	2.609	2.648	2.942

TCHVBZ-TCHVIZ MODEL		2400	2420	2440	2510	2560	2600	2630	2680	2710
❶	Nominal cooling capacity	kW	389.9	411.5	430.3	505.3	549.0	589.6	618.9	674.1
❶	E.E.R.		4.77	4.71	4.64	4.72	4.84	4.81	4.81	4.81
●	E.S.E.E.R.		5.47	5.51	5.38	5.51	5.75	5.71	5.6	5.5
❶	Absorbed power	kW	81.74	87.37	92.74	107.06	113.43	122.58	128.67	140.15
❸	Sound power	dB(A)	97	97	97	99	99	99	99	99
❸	Sound power	dB(A)	95	95	95	97	97	97	97	97
	Screw/step compressor	no.	2/6	2/6	2/6	2/6	2/6	2/6	2/6	2/6
	Circuits	no.	2	2	2	2	2	2	2	2
	Electrical supply	V-ph-Hz	400-3-50	400-3-50	400-3-50	400-3-50	400-3-50	400-3-50	400-3-50	400-3-50
DIMENSIONS AND WEIGHTS			2400	2420	2440	2510	2560	2600	2630	2680
	L - Width	mm	3.880	3.880	4.000	4.070	4.070	4.070	4.070	4.070
	H - Height	mm	1.840	1.840	1.840	1.960	1.960	1.960	1.960	1.960
	P - Depth	mm	1.300	1.300	1.300	1.300	1.300	1.300	1.300	1.300
❺	TCHVBZ weight	kg	2.366	2.393	2.438	2.923	3.257	3.280	3.297	3.364
❺	TCHVIZ weight	kg	2.796	2.823	2.868	3.353	3.687	3.710	3.227	3.794

TCHVBZ-TCHVIZ MODEL		2750	2790	2880	2930	21030	21110	21180	21260
❶	Nominal cooling capacity	kW	738.6	783.1	876.4	924.1	1014.2	1084.5	1152.2
❶	E.E.R.		4.75	4.7	4.83	4.72	4.77	4.81	4.83
●	E.S.E.E.R.		5.46	5.49	5.8	5.59	5.69	5.78	5.68
❶	Absorbed power	kW	155.49	166.62	181.45	195.78	212.62	225.47	238.55
❸	Sound power	dB(A)	99	99	99	99	99	99	99
❸	Sound power	dB(A)	97	97	97	97	97	97	97
	Screw/step compressor	no.	2/6	2/6	2/6	2/6	2/6	2/6	2/6
	Circuits	no.	2	2	2	2	2	2	2
	Electrical supply	V-ph-Hz	400-3-50	400-3-50	400-3-50	400-3-50	400-3-50	400-3-50	400-3-50
DIMENSIONS AND WEIGHTS			2750	2790	2880	2930	21030	21110	21180
	L - Width	mm	4.120	4.000	4.000	4.000	4.000	4.000	4.000
	H - Height	mm	1.840	1.840	1.910	1.910	1.950	1.950	1.950
	P - Depth	mm	1.300	1.300	1.300	1.300	1.300	1.300	1.300
❺	TCHVBZ weight	kg	3.880	4.366	4.596	4.629	4.739	4.830	4.878
❺	TCHVIZ weight	kg	4.310	4.796	5.026	5.059	5.169	5.260	5.308

TCHVBZ-TCHVIZ MODEL		31300	31350	31390	31460	31520	31590	31630
❶	Nominal cooling capacity	kW	1280.1	1327.0	1373.9	1433.9	1514.5	1576.5
❶	E.E.R.		4.91	4.86	4.8	4.8	4.84	4.84
●	E.S.E.E.R.		5.88	5.77	5.75	5.66	5.81	5.8
❶	Absorbed power	kW	260.71	273.05	286.23	298.73	312.91	325.72
❸	Sound power	dB(A)	101	101	101	102	102	102
❸	Sound power	dB(A)	99	99	99	100	100	100
	Screw/step compressor	no.	3/9	3/9	3/9	3/9	3/9	3/9
	Circuits	no.	3	3	3	3	3	3
	Electrical supply	V-ph-Hz	400-3-50	400-3-50	400-3-50	400-3-50	400-3-50	400-3-50
DIMENSIONS AND WEIGHTS			31300	31350	31390	31460	31520	31590
	L - Width	mm	4.940	4.940	4.940	4.940	4.940	4.940
	H - Height	mm	2.220	2.220	2.220	2.220	2.220	2.220
	P - Depth	mm	1.700	1.700	1.700	1.700	1.700	1.700
❺	TCHVBZ weight	kg	6.735	6.767	6.792	6.831	6.920	7.008
❺	TCHVIZ weight	kg	7.335	7.367	7.392	7.431	7.520	7.608

Data at the following conditions:

- ❶ Chilled water: 7/12°C. - Condenser input water: 30/35°C.
- ❸ Total sound power level in dB(A) based on measurements carried out in accordance with regulation UNI EN-ISO 9614.
- ❺ Empty weight.
- ESEER = (European seasonal EER) - Average European seasonal efficiency.
- TCHVIZ soundproofed version.

Performance according to EN 14511:2013

Low consumption Y-Flow E

TCEEY 115÷240

Cooling capacity: 13.7 ÷ 36.9 kW



- **Efficient condenserless units in R410a**

Cooling only condenserless units to couple with CCAMY remote condensers.

Range with hermetic Scroll compressors and R410A refrigerant gas.

Construction features

- Compressor: hermetic, rotary Scroll compressor, complete with thermal protection and casing heater.
- Water side heat exchanger: adequately insulated stainless steel plate heat exchanger, complete with antifreeze heater and water flow differential pressure switch.
- Control: microprocessor electronic control with Adaptive Function Plus logic.
- Structure: in galvanised sheet steel and varnished with polyester powder coating, internally covered with soundproof panelling.

Models

TCEEY: unit designed for cooling only.

Factory fitted accessories

- PUMP - Primary side (user): pump unit complete with circulation electric pump, expansion tank with membrane, safety valve, water fill/drain valve, manual air bleed valve, and pressure gauge. The pumps are available with low or high head.
- Soft start device.
- Silenced version with double panelling in the compressor compartment.
- Digital input for double set-point.
- 4-20 mA analogue input for shifting set-point.

Accessories supplied separately

- Outdoor air temperature probe for set-point compensation.
- Water filter.
- Rubber anti-vibration mountings.
- Remote keyboard with LCD display.
- Clock board.
- Interfaces for serial communication with other devices.
- RS485/USB serial converter.



TCEEY MODEL		115	118	122	125	230	240	
❶	Nominal cooling capacity	kW	13,7	16,4	20,1	23,3	36,9	
❶	EER		3,26	4,0	3,65	3,76	3,69	
❶	Absorbed power (*)	kW	4,2	4,1	5,5	6,2	10	
❶	Available head pressure of the standard electric pump	kPa	89	80	73	114	113	
❶	Available head pressure of high pressure pump	kPa	164	146	163	152	135	
❷	Sound power	dB(A)	58	58	62	63	67	
❷	Silenced set up sound power	dB(A)	53	53	57	58	62	
	Scroll / step compressors	no.	1 / 1	1 / 1	1 / 1	1 / 1	2 / 2	
	Circuits	no.	1	1	1	1	1	
	Electrical supply	V-ph-Hz	400-3+N-50	400-3+N-50	400-3+N-50	400-3+N-50	400-3+N-50	
DIMENSIONS AND WEIGHTS			115	118	122	125	230	240
	L - Width	mm	700	700	700	700	700	
	H - Height	mm	1140	1140	1140	1140	1140	
	P - Depth	mm	560	560	780	780	780	
❸	Weight	kg	166	166	191	214	251	

Data at the following conditions:

- ❶ Chilled water: 12/7°C - Dew point: 50°C (dew point)
- ❷ Sound power level in dB(A) based on measurements carried out in accordance with regulations UNI EN ISO 9614
- ❸ Weight refers to the most complete set up

(*) Unit without electric pumps.

Important note: the units can be combined with the corresponding models of the CCAMY remote condensers

Low consumption Y-Flow E

TCEEBY 245÷4360

Cooling capacity: 39.8÷320.9 kW



Cooling only condenserless units to couple with CCAMY remote condensers.

Range with hermetic Scroll compressors and R410A refrigerant gas.

Construction features

- Compressor: hermetic, rotary Scroll compressor, complete with thermal protection and casing heater.
- Water side heat exchanger: adequately insulated stainless steel plate heat exchanger, complete with antifreeze heater and water flow differential pressure switch.
- Control: microprocessor electronic control with Adaptive Function Plus logic.
- Structure: made of galvanised and painted sheet steel, with polyester powder coating.

Models

- TCEEBY: unit designed for cooling only.

Factory fitted accessories

- PUMP Primary side (user): pump unit complete with single or double circulation electric pump, expansion tank with membrane, safety valve, water fill/drain valve, manual air bleed valve, and pressure gauge. The pumps are available with low or high head.
- Power factor correction capacitors ($\cos\phi > 0.94$)
- Cooling circuit high and low pressure gauges.
- Power factor correction capacitors.
- Soft start device.
- Forced limit of power consumption.
- Silenced set up.
- Interfaces for serial communication with other devices.
- Digital input for double set-point.
- 4-20 mA analogue input for shifting set-point.
- Rubber anti-vibration mountings supplied loose.

Separately supplied accessories

- Outdoor air temperature probe for set-point compensation.
- Water filter.
- Rubber anti-vibration mountings.
- Clock board.
- Remote keyboard with display.
- RS485/USB serial converter.





TCEEBY MODEL		245	250	260	270	275	290	2100	2115	2130	2145	2165	2185
❶ Nominal cooling capacity	kW	39,8	47,3	53,6	61,3	67,9	80,6	91,7	103,4	115,0	128,2	145,7	162,3
❶ EER		3,29	3,38	3,30	3,76	3,39	3,49	3,38	3,34	3,29	3,34	3,26	3,19
❶ Absorbed power (*)	kW	12,1	14	16,2	18,2	20	23,1	27,1	31,0	35,0	38,4	44,7	50,8
❶ Available head pressure of the standard electric pump	kPa	116	108	134	94	84	86	117	119	133	117	119	106
❶ Available head pressure of high pressure pump	kPa	182	187	171	185	177	180	169	178	190	176	177	172
❷ Sound power	dB(A)	67	67	68	68	69	70	71	72	73	74	74	75
❷ Silenced set up sound power	dB(A)	63	63	64	64	65	66	67	68	69	70	70	71
Scroll / step compressors	no.	2 / 2	2 / 2	2 / 2	2 / 2	2 / 2	2 / 2	2 / 2	2 / 2	2 / 2	2 / 2	2 / 2	2 / 2
Circuits	no.	1	1	1	1	1	1	1	1	1	1	1	1
Electrical supply	V-ph-Hz	400-3+N-50	400-3+N-50	400-3+N-50	400-3+N-50	400-3+N-50	400-3+N-50	400-3+N-50	400-3+N-50	400-3+N-50	400-3+N-50	400-3+N-50	400-3+N-50
DIMENSIONS AND WEIGHTS													
L - Width	mm	1020	1020	1020	1020	1020	1020	1270	1270	1270	1270	1270	1270
W - Width (PUMP set up)	mm	1250	1250	1250	1250	1250	1250	1500	1500	1500	1500	1500	1500
H - Height	mm	1470	1470	1470	1470	1470	1470	1620	1620	1620	1620	1620	1620
P - Depth	mm	870	870	870	870	870	870	870	870	870	870	870	870

TCEEBY MODEL		4180	4205	4235	4260	4290	4330	4360
❶ Nominal cooling capacity	kW	161,2	182,9	205,0	229,4	253,8	287,4	320,9
❶ EER		3,53	3,50	3,48	3,49	3,50	3,42	3,36
❶ Absorbed power (*)	kW	45,7	52,3	58,9	65,8	72,6	84,0	95,5
❶ Available head pressure of the standard electric pump	kPa	140	132	114	117	111	136	168
❶ Available head pressure of high pressure pump	kPa	195	200	196	240	273	241	257
❷ Sound power	dB(A)	77	77	78	79	80	81	82
❷ Silenced set up sound power	dB(A)	75	75	76	77	78	79	80
Scroll / step compressors	no.	4 / 4	4 / 4	4 / 4	4 / 4	4 / 4	4 / 4	4 / 4
Circuits	no.	2	2	2	2	2	2	2
Electrical supply	V-ph-Hz	400-3+N-50	400-3+N-50	400-3+N-50	400-3+N-50	400-3+N-50	400-3+N-50	400-3+N-50
DIMENSIONS AND WEIGHTS								
L - Width	mm	2600	2600	2600	2600	2600	2600	2600
W - Width (PUMP set up)	mm	3734	3734	3734	3734	3734	3734	3734
H - Height	mm	1860	1860	1860	1860	1860	1860	1860
P - Depth	mm	870	870	870	870	870	870	870

Data at the following conditions:

- ❶ Chilled water: 12/7°C - Dew point: 50°C (dew point)
- ❷ Sound power level in dB(A) based on measurements carried out in accordance with regulations UNI EN ISO 9614
- (*) Unit without electric pumps.

Important note: models 245÷2185 can be combined with the corresponding models of the CCAMY remote condensers. For models 4180÷4360 refer to the table below

Recommended combinations with CCAMY condensers for models TCEEBY 4180÷4360								
TCEEBY MODEL		4180	4205	4235	4260	4290	4330	4360
CCAMY MODEL	Circuit 1	CCAMY 290	CCAMY 2110	CCAMY 2115	CCAMY 2130	CCAMY 2145	CCAMY 2165	CCAMY 2185
	Circuit 2	CCAMY 290	CCAMY 2110	CCAMY 2115	CCAMY 2130	CCAMY 2145	CCAMY 2165	CCAMY 2185

Z-Flow E

TCEVZ 1200÷31630

Cooling capacity: 171.9÷1,424.8 kW



TCEVBZ 2630

- Efficient condenserless unit in R134a
- 33 sizes in standard and soundproofed versions
- Wide range of standard equipment
- Built-in MASTER/SLAVE management

Cooling only condenserless units. Range with semi-hermetic screw compressors and R134a refrigerant gas.

Construction features

- Compressor: high energy efficiency semi-hermetic screw compressor, with star-delta or part-winding limited start up (depending on models) and complete with integral protection, casing heater and refrigerant gas outlet piping shut-off valve.
- Electronic expansion valve: as standard on all models.
- Water side heat exchanger (evaporator): dry expansion shell and tube exchanger with counterflow heat exchange, complete with closed cell polyurethane rubber foam insulation, water flow differential pressure switch and Victaulic fittings.
- Control: microprocessor electronic control.
- Structure: made of galvanised and painted steel plate with polyester powder coating.
- The unit is also complete with:
 - clock board;
 - Master/Slave control up to 4 units in parallel.

Versions

- B -Standard version (TCEVBZ).
- I -Soundproofed version with soundproofed compressor cover (TCEVIZ).

Models

- TCEVBZ: unit designed for cooling only.
- TCEVIZ: soundproofed unit designed for cooling only.

Factory fitted accessories

- Power factor capacitors ($\cos\phi > 0.94$).
- Thermal overload switches
- Forced limit of power consumption.
- Soft starter.
- Compression suction shutoff valves
- Linear capacity control compressors (50-100 % for each compressor).
- Evaporator antifreeze resistance.
- Digital input for double set-point.
- Compressor oil level sensor.
- Control of min/max power supply voltage.
- 4-20 mA analogue input for shifting set-point.
- Interfaces for serial communication with other devices.
- Spring antivibration mountings.
- Antivibration rubber mountings.

Separately supplied accessories

- Remote keyboard with display.
- Rhoss supervisors for unit monitoring and remote management.
- Rhoss sequencer for integrated management of several water chillers.



TCEVBZ-TCEVIZ MODEL		1200	1230	1280	1310	1350	1410	1460	1530	1590	
❶	Nominal cooling capacity	kW	171,9	190,8	238,1	260,4	300,6	346,2	399,7	446,4	508,9
❶	E.E.R.		3,4	3,3	3,3	3,3	3,4	3,3	3,3	3,3	3,4
❶	Absorbed power	kW	50,5	58,1	72,2	79,0	88,1	104,0	122,2	135,3	149,7
❷	Sound power	dB(A)	94	94	97	97	97	97	97	98	98
❸	Sound power	dB(A)	92	92	95	95	95	95	95	96	96
	Screw/step compressor	no.	1/3	1/3	1/3	1/3	1/3	1/3	1/3	1/3	1/3
	Circuits	no.	1	1	1	1	1	1	1	1	1
	Electrical supply	V-ph-Hz	400-3-50	400-3-50	400-3-50	400-3-50	400-3-50	400-3-50	400-3-50	400-3-50	400-3-50
DIMENSIONS AND WEIGHTS			1200	1230	1280	1310	1350	1410	1460	1530	1590
	L - Width	mm	3.440	3.440	3.420	3.440	3.450	3.450	3.450	3.460	3.460
	H - Height	mm	1.460	1.460	1.460	1.460	1.640	1.640	1.640	1.740	1.740
	P - Depth	mm	1.000	1.000	1.000	1.000	1.000	1.000	1.000	1.000	1.000
❺	TCEVBZ weight	kg	1.078	1.093	1.410	1.414	1.557	2.032	2.038	2.252	2.281
❻	TCEVIZ weight	kg	1.333	1.348	1.665	1.669	1.812	2.287	2.293	2.507	2.536

TCEVBZ-TCEVIZ MODEL		2400	2420	2440	2510	2560	2600	2630	2680	2710	
❶	Nominal cooling capacity	kW	335,8	356,6	372,1	431,9	473,4	506,4	529,3	581,4	614,1
❶	E.E.R.		3,3	3,3	3,2	3,3	3,3	3,3	3,3	3,5	3,5
❶	Absorbed power	kW	100,7	108,3	115,7	130,6	144,4	151,5	158,4	168,0	176,6
❷	Sound power	dB(A)	97	97	97	99	99	99	99	99	99
❸	Sound power	dB(A)	95	95	95	97	97	97	97	97	97
	Screw/step compressor	no.	2/6	2/6	2/6	2/6	2/6	2/6	2/6	2/6	2/6
	Circuits	no.	2	2	2	2	2	2	2	2	2
	Electrical supply	V-ph-Hz	400-3-50	400-3-50	400-3-50	400-3-50	400-3-50	400-3-50	400-3-50	400-3-50	400-3-50
DIMENSIONS AND WEIGHTS			2400	2420	2440	2510	2560	2600	2630	2680	2710
	L - Width	mm	3.870	3.870	3.870	4.070	4.070	4.070	4.070	4.070	4.070
	H - Height	mm	1.490	1.490	1.490	1.610	1.610	1.610	1.610	1.610	1.610
	P - Depth	mm	1.300	1.300	1.300	1.300	1.300	1.300	1.300	1.300	1.300
❺	TCEVBZ weight	kg	1.797	1.811	1.819	2.311	2.629	2.637	2.638	2.698	2.733
❻	TCEVIZ weight	kg	2.227	2.241	2.249	2.741	3.059	3.067	3.068	3.128	3.163

TCEVBZ-TCEVIZ MODEL		2750	2790	2880	2930	21030	21110	21180	21260	
❶	Nominal cooling capacity	kW	647,8	681,6	753,9	801,4	896,1	959,4	1.027,8	1.101,5
❶	E.E.R.		3,4	3,3	3,3	3,3	3,5	3,5	3,6	3,7
❶	Absorbed power	kW	192,1	207,6	226,5	244,4	257,9	271,0	285,5	299,4
❷	Sound power	dB(A)	99	99	99	99	99	99	99	99
❸	Sound power	dB(A)	97	97	97	97	97	97	97	97
	Screw/step compressor	no.	2/6	2/6	2/6	2/6	2/6	2/6	2/6	2/6
	Circuits	no.	2	2	2	2	2	2	2	2
	Electrical supply	V-ph-Hz	400-3-50	400-3-50	400-3-50	400-3-50	400-3-50	400-3-50	400-3-50	400-3-50
DIMENSIONS AND WEIGHTS			2750	2790	2880	2930	21030	21110	21180	21260
	L - Width	mm	4.120	4.000	4.000	4.000	4.000	4.000	4.000	4.000
	H - Height	mm	1.490	1.490	1.560	1.560	1.600	1.600	1.600	1.600
	P - Depth	mm	1.300	1.300	1.300	1.300	1.300	1.300	1.300	1.300
❺	TCEVBZ weight	kg	3.176	3.631	3.844	3.859	3.936	3.993	4.024	4.044
❻	TCEVIZ weight	kg	3.606	4.061	4.272	4.289	4.366	4.423	4.454	4.474

TCEVBZ-TCEVIZ MODEL		31300	31350	31390	31460	31520	31590	31630	
❶	Nominal cooling capacity	kW	1.129,6	1.178,3	1.227,0	1.287,5	1.340,1	1.388,5	1.424,8
❶	E.E.R.		3,6	3,6	3,5	3,5	3,5	3,5	3,5
❶	Absorbed power	kW	314,1	331,8	349,5	367,1	380,4	393,4	406,4
❷	Sound power	dB(A)	101	101	101	102	102	102	102
❸	Sound power	dB(A)	99	99	99	100	100	100	100
	Screw/step compressor	no.	3/9	3/9	3/9	3/9	3/9	3/9	3/9
	Circuits	no.	3	3	3	3	3	3	3
	Electrical supply	V-ph-Hz	400-3-50	400-3-50	400-3-50	400-3-50	400-3-50	400-3-50	400-3-50
DIMENSIONS AND WEIGHTS			31300	31350	31390	31460	31520	31590	31630
	L - Width	mm	4.940	4.940	4.940	4.940	4.940	4.940	4.940
	H - Height	mm	1.620	1.620	1.620	1.620	1.620	1.620	1.620
	P - Depth	mm	2.000	2.000	2.000	2.000	2.000	2.000	2.000
❺	TCEVBZ weight	kg	5.555	5.570	5.585	5.600	5.678	5.710	5.790
❻	TCEVIZ weight	kg	6.155	6.170	6.185	6.200	6.278	6.310	6.390

Data at the following conditions:

- ❶ Chilled water: 12/7°C - Dew point: 50°C (dew point).
- ❷ Total sound power level in dB(A) based on measurements carried out in accordance with regulation UNI EN-ISO 9614.
- ❸ Weight of fully accessorised unit when empty.
- ❹ TCEVIZ soundproofed version.

Compact-Y EXP SM - TXAEY 117÷130

Compact-Y EXP MD - TXAEY 133÷265

Low consumption Y-Pack EXP - TXAEY 280÷4320

Low consumption WinPOWER EXP - TXAEY 4400÷6660

Z-Power EXP - TXAVZ 2420÷2700

Low consumption Comby-Flow EXP - TXHEY 105÷112

Low consumption Y-Flow EXP - TXHEY 245÷4450

Z-Flow EXP - TXHVZ 2410÷2740

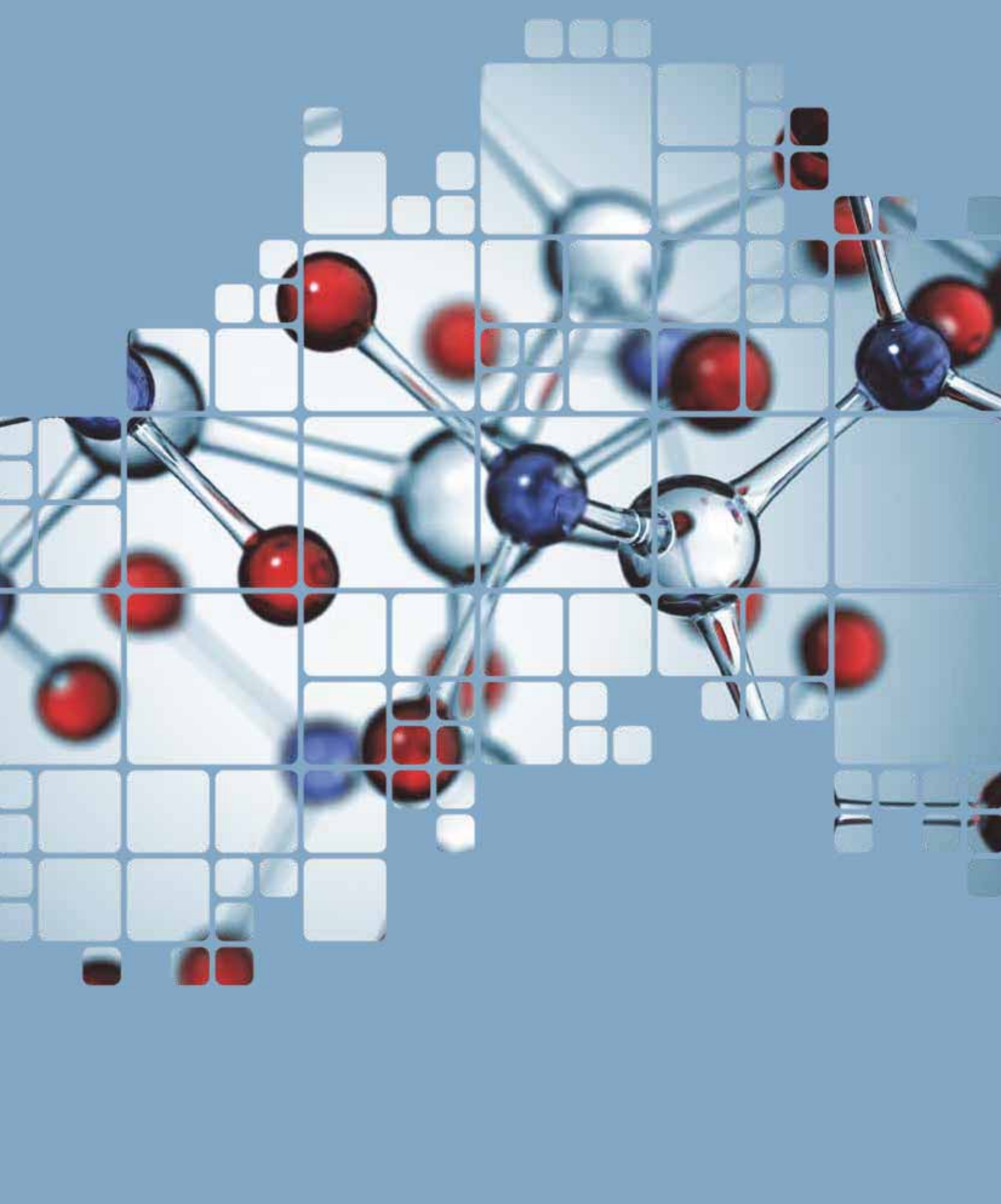

EXP - POLYVALENT SYSTEMS

Compact-Y EXP SM

TXAEY 117÷130

Cooling capacity: 17.7÷29.1 kW - Heating capacity: 17.6÷34 kW



• T.E.R. * up to 6.72

EXPsystems - Multi-purpose ecological air-cooled system with axial fans.

Range with hermetic Scroll compressors and R410A refrigerant gas.

Construction features

- Compressor: hermetic, rotary Scroll compressor, complete with thermal protection and casing heater.
- Main and secondary heat exchangers: suitably insulated stainless steel plates, complete with antifreeze heater and water flow differential pressure switch.
- Air side heat exchanger: featuring finned coil with copper pipes and aluminium fins, complete with protection grille.
- Fan: electric axial fans with external rotor, equipped with internal thermal protection, protection grilles and proportional electronic device for continuous fan rotation speed regulation.
- Control: microprocessor electronic control with AdaptiveFunction logic.
- Structure: in galvanised and painted sheet steel, complete with condensation drain pan.

Models

- TXAEY: EXPsystems unit.

PUMP set up

- Pump unit for primary circuit complete with: circulation or electric circulation pump, membrane expansion tank, manual air bleed valve and safety valve, and pressure gauge.

Factory fitted accessories

- Silenced set-up.
- Unit base antifreeze electric heater for operation in heat pump mode at low outdoor air temperatures.
- Digital input for double set-point.
- 4-20 mA analogue input for shifting set-point.
- Copper/pre-painted aluminium or copper/copper coils.

Separately supplied accessories

- Rubber anti-vibration mounts.
- Water filter.
- Remote keypad with display.
- Clock board.
- Interfaces for serial communication with other devices.
- RS485/USB serial converter.
- Rhoss supervisors for unit monitoring and remote management.



MODEL TXAEY		117	124	130
Radiant systems				
❶ Cooling capacity (AUTOMATIC 1)	kW	23,8	32,2	38,9
❸ Recovery heating capacity (AUTOMATIC 2)	kW	27,2	39,8	48,3
❷ Heating capacity (SELECT 1-2 AUTOMATIC 3)	kW	18,3	26,8	35,4
Fan coil systems				
❹ Nominal cooling capacity (AUTOMATIC 1)	kW	17,7	24	29,1
❷ Recovery heating capacity (AUTOMATIC 2)	kW	20,8	30,4	37,2
❺ Nominal heating capacity (SELECT 1-2 AUTOMATIC 3)	kW	17,6	25,7	34
❹ Absorbed power (AUTOMATIC 1)	kW	6,6	9,4	11,8
❷ Absorbed power (*) (AUTOMATIC 2)	kW	4,9	7,4	9,8
❺ Absorbed power (SELECT 1-2 AUTOMATIC 3)	kW	6,2	9,1	11,3
❷ T.E.R. (AUTOMATIC 2)		6,62	6,72	6,13
MODEL TXAEY SEASONAL PERFORMANCE IN HEATING MODE				
(∅) Pdesign (EN 14825)	kW	19	27	36
(∅) SCOP (EN 14825)		3,23	3,24	3,28
(§) η_s	%	126	127	128
(§) Energy class		A+	A+	A+
❻ Sound pressure	dB(A)	50	52	53
❻ Silenced set up sound pressure	dB(A)	46	49	50
Scroll/step compressor	no.	1/1	1/1	1/1
Circuits	no.	1	1	1
❹ Available head pressure of the standard electric pump	kPa	130	131	112
Electrical supply	V-ph-Hz	400-3+N-50	400-3+N-50	400-3+N-50
DIMENSIONS AND WEIGHTS				
L - Width	mm	1522	1522	1822
H - Height	mm	1090	1280	1510
P - Depth	mm	580	600	695
TXAEY weight	kg	220	280	370

Data at the following conditions:

- ❶ Air: 35°C - Water: 23/18°C.
- ❷ Air: 7°C D.B. - 6°C W.B. - Water: 30/35°C.
- ❸ Evaporator water: 18/23°C. Recovery output water 45°C - Nominal flow rate.
- ❹ Air: 35°C - Water: 12/7°C.
- ❺ Air: 7°C D.B. - 6°C W.B. - Water: 40/45°C.
- ❻ In open field (Q = 2) at 5 m from the unit.
- ❼ Evaporator water: 12/7°C. Recovery output water 45°C - Nominal flow rate.

(*) Unit without electric pump.

Performance according to EN 14511:2013 Set up with electric pump.

T.E.R.: Total efficiency ratio

(∅) In Average climatic conditions, low temperature application

(§) Seasonal energy efficiency: low temperature application in Average climate (EU Regulations N°811/213 and N°813/2013)

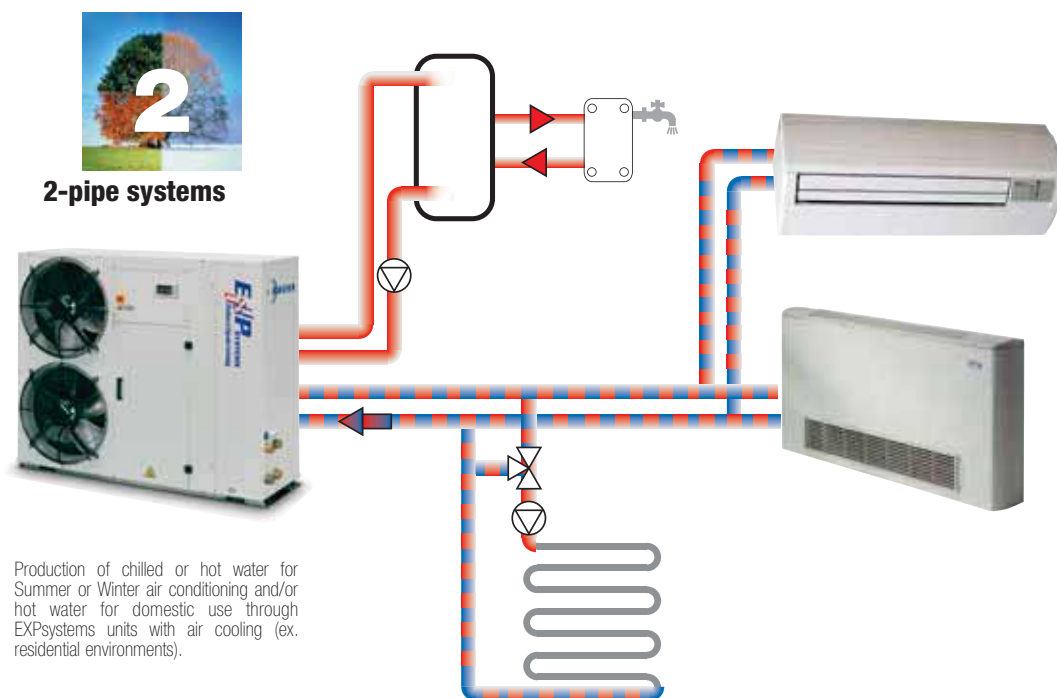

Compact-Y EXP MD

TXAEY 133÷265

Cooling capacity: 33.8÷61.6 kW - Heating capacity: 39.4÷68.3 kW



• T.E.R. (°) up to 7.48

EXPsystems - Multi-purpose ecological air-cooled system with axial fans.

Range with hermetic Scroll compressors and R410A refrigerant gas.

Construction features

- Compressor: scroll type, rotary, hermetic complete with thermal protection and casing heater.
- Main and secondary heat exchangers: suitably insulated stainless steel plates, complete with antifreeze heater and water flow differential pressure switch.
- Air side heat exchanger: featuring finned coil with copper pipes and aluminium fins, complete with protection grille.
- Fan: electric axial fans with external rotor, equipped with internal thermal protection, accident protection grilles and proportional electronic device for continuous fan rotation speed regulation.
- Control: microprocessor electronic control with AdaptiveFunction logic.
- Structure: made of galvanised and painted steel plate.
- The unit is also complete with:
 - display of cooling circuit high and low pressure;
 - clock board.

Models

- TXAEY: standard EXPsystems unit.

Factory fitted accessories

- PUMP (only for main circuit) with inertial buffer tank and single or double pump, including an automatic pump in standby (mod. 245÷265) complete with expansion tank, air bleed valves, safety valve and water side pressure gauge. The electric pumps are available in the low or high pressure versions.
- TANK&PUMP (only for main circuit) with inertial buffer tank and single or double pump, including an automatic pump in standby (mod. 245÷265) complete with expansion tank, air bleed valves, safety valve and water side pressure gauge. The electric pumps are available in the low or high pressure versions.
- Silenced set up.
- Cooling circuit high and low pressure gauges.
- Antifreeze heater for buffer tank and pumps.
- Digital input for double set-point.
- 4-20mA analogue input for shifting set-point.
- Copper/pre-painted aluminium or copper/copper coils.

Separately supplied accessories

- Rubber anti-vibration mounts.
- Water filter.
- Remote keypad with display.
- Interfaces for serial communication with other devices.
- RS485/USB serial converter.
- Rhoss supervisors for unit monitoring and remote management.



MODEL TXAEY		133	245	250	260	265	
❶	Nominal cooling capacity (AUTOMATIC 1)	kW	33,8	42,4	50,3	57,9	61,6
❸	Recovery heating capacity (AUTOMATIC 2)	kW	44,2	54,4	65	71,8	81,1
❷	Nominal heating capacity (SELECT 1-2 AUTOMATIC 3)	kW	39,4	48,1	56,2	62,5	68,3
❶	Absorbed power (AUTOMATIC 1)	kW	13,5	17	18,8	21,9	24,4
❸	Absorbed power (AUTOMATIC 2)	kW	11,5	13,6	15,5	17,1	19
❷	Absorbed power (SELECT 1-2 AUTOMATIC 3)	kW	13,6	16,8	18,9	20,9	23,7
❸	T.E.R. (AUTOMATIC 2)		6,25	6,94	7,3	7,32	7,48
MODEL TXAEY SEASONAL PERFORMANCE IN HEATING MODE							
(∅)	Pdesign (EN 14825)	kW	39	48	56	62	68
(∅)	SCOP (EN 14825)		3,28	3,73	3,75	3,79	3,74
(§)	η_s	%	128	146	147	149	146
(§)	Energy class		A+	A+	A+	A+	A+
❹	Sound pressure	dB(A)	54	56	56	57	57
❹	Silenced set up sound pressure	dB(A)	51	53	53	54	54
	Scroll/step compressor	no.	1/1	2/1	2/1	2/1	2/1
	Circuits	no.	1	1	1	1	1
	Electrical supply	V-ph-Hz	400-3+N-50	400-3+N-50	400-3+N-50	400-3+N-50	400-3+N-50
DIMENSIONS AND WEIGHTS			133	245	250	260	265
L - Width	mm		1660	2260	2260	2260	2260
H - Height	mm		1570	1570	1570	1570	1570
P - Depth	mm		1000	1000	1000	1000	1000
TXAEY weight	kg		470	735	775	795	825

Data at the following conditions:

- ❶ Air: 35°C - Water: 12/7°C.
- ❷ Air: 7°C D.B. - 6°C W.B. - Water: 40/45°C.
- ❸ Evaporator water: 12/7°C. Recovery output water 45°C - Nominal flow rate.
- ❹ In open field (Q = 2) at 5 m from the unit.

Performance according to EN 14511:2013

T.E.R.: Total efficiency ratio

(∅) In Average climatic conditions, low temperature application

(§) Seasonal energy efficiency: low temperature application in Average climate (EU Regulations N°811/213 and N°813/2013)

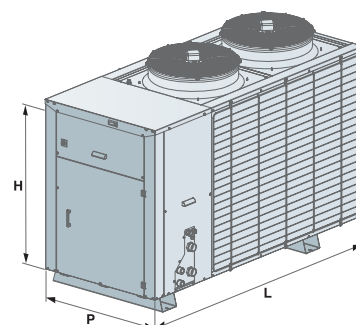

Low consumption Y-Pack EXP

TXAEY 280÷4320

Cooling capacity: 81 ÷ 334 kW - Heating capacity: 84 ÷ 353 kW



TXAESY 4320 with
accessory coil protection
grilles



• T.E.R. ** up to 8.18

EXPsystems - Multi-purpose ecological air-cooled system with axial fans.

Range with hermetic Scroll compressors and R410A refrigerant gas.

Construction features

- Compressor: scroll type, rotary, hermetic complete with thermal protection and casing heater.
- Main and secondary heat exchangers: crossed flow stainless steel plate exchangers, complete with antifreeze heater, closed cell polyurethane foam rubber insulation and water flow differential pressure switch.
- Air side heat exchanger: finned coil with copper pipes and aluminium fins.
- Fan: electric axial fans with EC motor with continuous adjustment of the rotation speed, equipped with internal thermal protection and complete with protection grilles.
- Control: microprocessor electronic control with Adaptive Function Plus logic.
- Structure: made of galvanised and painted steel plate with polyester powder coating.
- The unit is also complete with:
 - fan and compressor circuit breaker switches;
 - clock board;
 - electronic expansion valve;
 - display of cooling circuit high/low pressure.

Versions

- T - High efficiency version with fans with EC motor
- S - Silenced version complete with soundproofed compressor technical compartment, lower fan speed fans with EC motor.

Models

- TXAEY: EXPsystems unit.
- TXAESY: silenced EXPsystems unit.

Factory fitted accessories

- PUMP (for main and secondary circuits) with single or double pump, including an automatic pump in standby. The pumps are available in the low or high pressure versions.
- TANK&PUMP (for main circuit only) with built-in buffer tank and single or double pump, complete with expansion tank, air bleed valves, safety valve and water side pressure gauge.
- Power factor correction capacitors ($\cos\phi > 0.94$).
- Soft starter forced limit of power consumption.
- Cooling circuit high and low pressure gauges.
- Metal filters or coil protection grilles.
- Copper/copper or copper/pre-painted aluminium coils.
- Digital input for double set-point.
- 4-20 mA analogue input for shifting set-point.
- Buffer tank antifreeze heaters and electric pumps if present.
- Interfaces for serial communication with other devices.
- Anti-vibration mountings.

Separately supplied accessories

- Remote keyboard with display.
- Rhoss supervisors for unit monitoring and remote management.
- Rhoss sequencer for integrated management of several water chillers.

* Refer to the Rhoss website to learn which heat pump models can avail of the incentives.

** T.E.R. Total Efficiency Ratio in total heat recovery mode AUTOMATIC 2.



TXAETY MODEL		280	2100	2130	4160	4200	4260	4320	
❶	Nominal cooling capacity (AUTOMATIC 1)	kW	84	108	135	163	207	264	334
❷	Recovery heating capacity (AUTOMATIC 2)	kW	108	140	174	215	272	346	440
❸	Nominal heating capacity (SELECT 1-2 AUTOMATIC 3)	kW	86	111	139	171	227	281	353
❹	Absorbed power (AUTOMATIC 1)	kW	26,8	34,8	43,4	56,1	72,7	92,1	117,3
❺	Absorbed power (AUTOMATIC 2)	kW	23,6	32,2	39,3	51,5	65,2	81,4	106,5
❻	Absorbed power (SELECT 1-2 AUTOMATIC 3)	kW	25,3	33,5	42,4	54,5	73,1	91,5	116,5
	E.E.R. (AUTOMATIC 1)		3,13	3,1	3,11	2,91	2,85	2,87	2,85
	T.E.R. (AUTOMATIC 2)		8,18	7,76	7,89	7,36	7,39	7,53	7,36
	C.O.P. (SELECT 1-2 AUTOMATIC 3)		3,4	3,31	3,28	3,14	3,11	3,07	3,03
Ⓢ	Sound pressure	dB(A)	52	52	53	54	59	61	61
Ⓣ	Sound power	dB(A)	84	84	85	86	91	93	93
TXAESY MODEL		280	2100	2130	4160	4200	4260	4320	
❶	Nominal cooling capacity (AUTOMATIC 1)	kW	81	104	130	157	200	255	317
❷	Recovery heating capacity (AUTOMATIC 2)	kW	108	140	174	215	272	346	440
❸	Nominal heating capacity (SELECT 1-2 AUTOMATIC 3)	kW	84	108	136	167	221	274	344
❹	Absorbed power (AUTOMATIC 1)	kW	27	35,2	43,9	56,6	73,7	92,9	118,8
❺	Absorbed power (AUTOMATIC 2)	kW	23,6	32,2	39,3	51,5	65,2	81,4	106,5
❻	Absorbed power (SELECT 1-2 AUTOMATIC 3)	kW	24,3	32,1	40,7	53,4	70,4	88,4	111,8
	E.E.R. (AUTOMATIC 1)		3	2,95	2,96	2,77	2,71	2,74	2,67
	C.O.P. (SELECT 1-2 AUTOMATIC 3)		3,46	3,36	3,34	3,13	3,14	3,1	3,08
Ⓢ	Sound pressure	dB(A)	49	49	50	51	54	57	57
Ⓣ	Sound power	dB(A)	81	81	82	83	86	89	89
TXAETY MODEL SEASONAL PERFORMANCE IN HEATING MODE									
(∇)	P _{design} (EN 14825)	kW	77	98	124	153	201	252	314
(∇)	SCOP (EN 14825)		3,91	3,77	3,73	3,39	3,34	3,29	3,29
(§)	η _s	%	153	148	146	133	130	129	129
MODEL TXAESY SEASONAL PERFORMANCE IN HEATING MODE									
(∇)	P _{design} (EN 14825)	kW	75	95	121	148	196	246	305
(∇)	SCOP (EN 14825)		4,02	3,85	3,83	3,44	3,4	3,37	3,35
(§)	η _s	%	158	151	150	135	133	132	131
MODEL		280	2100	2130	4160	4200	4260	4320	
	Scroll/step compressor	no.	2/2	2/2	2/2	4/4	4/4	4/4	
	Circuits	no.	2	2	2	2	2	2	
	Electrical supply	V-ph-Hz	400-3+N-50	400-3+N-50	400-3+N-50	400-3+N-50	400-3+N-50	400-3+N-50	
SIZES		280	2100	2130	4160	4200	4260	4320	
	L - Width	mm	2600	2600	3700	3700	4800	4800	
	H - Height	mm	2000	2000	2000	2000	2030	2030	
	P - Depth	mm	2090	2090	2090	2090	2090	2090	

Data at the following conditions:

- ❶ Air: 35°C - Water: 12/7°C.
- ❷ Air: 7°C D.B. - 6°C W.B. - Water: 40/45°C.
- Ⓢ In open field (Q = 2) at 10 m from the unit.
- ❹ Evaporator water: 12/7°C. Recovery output water 45°C - Nominal flow rate.
- Ⓣ Total sound power level in dB(A) based on measurements carried out in accordance with regulation UNI EN-ISO 9614.
- (∇) In Average climatic conditions, low temperature application
- (§) Seasonal energy efficiency: low temperature application in Average climate (EU Regulations N°811/213 and N°813/2013)

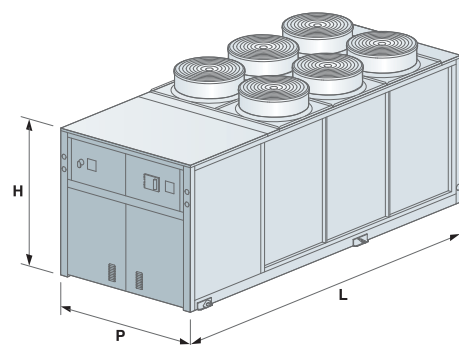

Low consumption WinPOWER EXP

TXAEY 4400÷6660

Cooling capacity: 362÷650 kW - Heating capacity: 404÷704 kW



TXAEY 6580 with STE accessory and with RPB coil protection grille accessory

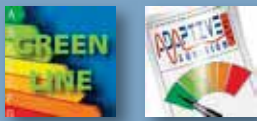

- Multi-purpose Class A units with TER up to 7.9
- Extended operating limits
- Units for 2, 4 and 6-pipe systems

EXPsystems - Multi-purpose ecological air-cooled system with axial fans.
Range with hermetic Scroll compressors and R410A refrigerant gas.

Construction features

- Compressor: scroll type, rotary, hermetic complete with thermal protection and casing heater.
- Up to 6 capacity steps with high efficiency at partial loads.
- Main and secondary heat exchangers: crossed flow stainless steel plate exchangers, complete with antifreeze heater, closed cell polyurethane foam rubber insulation and water flow differential pressure switch.
- Air side heat exchanger: finned coil with copper pipes and aluminium fins.
- Fan: external rotor axial type electric fans, equipped with internal thermal protection, accident protection grilles and a proportional electronic device for continuous fan rotation speed regulation (T version; fans with an EC motor are standard in the Q version)
- Control: microprocessor electronic control with Adaptive Function Plus logic.
- Structure: load bearing structure made of galvanised sheet steel and painted with polyester powders.
- The unit is also complete with:
 - fan and compressor circuit breaker switches, heat exchanger antifreeze heater;
 - display of cooling circuit high and low pressure;
 - electronic expansion valve;
 - clock board.

Versions

- T - High efficiency version.
- Q - Supersilenced version complete with soundproofed compressor technical compartment, super-low fan speed fans with EC motor.

Models

- TXAETY: EXPsystems unit.
- TXAEQY: supersilenced EXPsystems unit.

Factory fitted accessories

- Shell and tube main and secondary heat exchangers.
- PUMP with single or double electric pump, including an automatic pump in standby. The electric pumps are available in the main and secondary/recovery heat exchanger low or high head set-ups.
- TANK&PUMP with 700-1000 litre integrated buffer tank (depending on models) and single or double electric pump, complete with expansion tank, air vent valves, safety valve and water side pressure gauge.
- Desuperheater.
- -15°C condensing control with fans with EC motor (standard in the Q versions).
- Condensing control with over-pressure fans (T version only).
- Power factor correction capacitors ($\cos\phi > 0.94$).
- Forced limit of power consumption.
- Forced noise limit.
- Energy parameters measuring device.
- Optimised energy efficiency.
- Soft starter.
- Compressor box and soundproofed cooling circuit.
- Compressor soundproof enclosures.
- Cooling circuit delivery and intake valves.
- Refrigerant leak detector.
- Cooling circuit high and low pressure gauges.
- Double safety valves.
- Coil protection nets or metal filters.
- Bottom compartment protection nets.
- Copper/pre-painted aluminium or copper/copper coils.
- Digital input for double set-point.
- 4-20 mA analogue input for shifting set-point.
- Electrical panel antifreeze heater, buffer tank, electric pumps and desuperheater, if present.
- Interfaces for serial communication with other devices.
- Spring anti-vibration mounts.

Separately supplied accessories

- Remote keyboard with display.
- Thermostat with display.
- Rhoss supervisors for unit monitoring and remote management.
- Rhoss sequencer for integrated management of several water chillers.



TXAETY MODEL		4400	4440	6520	6580	6660	
❶	Nominal cooling capacity (AUTOMATIC 1)	kW	398	436	527	579	650
❷	Recovery heating capacity (AUTOMATIC 2)	kW	515	567	685	759	845
❸	Nominal heating capacity (SELECT 1-2 AUTOMATIC 3)	kW	425	469	568	628	704
❹	Absorbed power (AUTOMATIC 1)	kW	131	144	175	197	216
❺	Absorbed power (AUTOMATIC 2)	kW	116,6	128,6	157	179	194,4
❻	Absorbed power (SELECT 1-2 AUTOMATIC 3)	kW	130	143	175	193	215
	E.E.R. (AUTOMATIC 1)		3,04	3,03	3,01	2,94	3,01
	T.E.R. (AUTOMATIC 2)		7,9	7,8	7,8	7,5	7,7
	C.O.P. (SELECT 1-2 AUTOMATIC 3)		3,27	3,28	3,25	3,25	3,27
Ⓝ	Sound pressure	dB(A)	76	76,5	76,5	76,5	76,5
Ⓞ	Sound power	dB(A)	96	97	97	97	98
TXHEBY MODEL		4400	4440	6520	6580	6660	
❶	Nominal cooling capacity (AUTOMATIC 1)	kW	362	391	476	517	582
❷	Recovery heating capacity (AUTOMATIC 2)	kW	515	567	685	759	845
❸	Nominal heating capacity (SELECT 1-2 AUTOMATIC 3)	kW	404	444	546	597	668
❹	Absorbed power (AUTOMATIC 1)	kW	141	158	191	221	235
❺	Absorbed power (AUTOMATIC 2)	kW	116,6	128,6	157	179	194,4
❻	Absorbed power (SELECT 1-2 AUTOMATIC 3)	kW	124	136	167	183	204
	E.E.R. (AUTOMATIC 1)		2,57	2,47	2,49	2,34	2,48
	C.O.P. (SELECT 1-2 AUTOMATIC 3)		3,26	3,26	3,27	3,26	3,27
Ⓝ	Sound pressure	dB(A)	53,5	54,5	54,5	54,5	56,5
Ⓞ	Sound power	dB(A)	86	87	87	87	89
TXAETY MODEL SEASONAL PERFORMANCE IN HEATING MODE							
(∅)	P _{design} (EN 14825)	kW	361	-	-	-	-
(∅)	SCOP (EN 14825)		3,63	-	-	-	-
(§)	η _s	%	142	-	-	-	-
TXAEQY MODEL SEASONAL PERFORMANCE IN HEATING MODE							
(∅)	P _{design} (EN 14825)	kW	344	382	-	-	-
(∅)	SCOP (EN 14825)		3,63	3,64	-	-	-
(§)	η _s	%	142	143	-	-	-
MODEL		4400	4440	6520	6580	6660	
	Scroll/step compressor	no.	4/4	4/4	6/6	6/6	6/6
	Circuits	no.	2	2	2	2	2
	Electrical supply	V-ph-Hz	400-3-50	400-3-50	400-3-50	400-3-50	400-3-50
SIZES		4400	4440	6520	6580	6660	
	L - Width	mm	4840	4840	5940	5940	6840
	H - Height	mm	2450	2450	2450	2450	2450
	P - Depth	mm	2260	2260	2260	2260	2260
Ⓟ	TXAETY weight	kg	3650	3760	4480	4580	5250
Ⓟ	TXAEQY weight	kg	4340	4360	5270	5370	6070

Data at the following conditions:

- ❶ Air: 35°C - Water: 12/7°C.
- ❷ Air: 7°C D.B. - 6°C W.B. - Water: 40/45°C.
- ❸ In open field (Q = 2) at 10 m from the unit.
- ❹ Evaporator water: 12/7°C. Recovery output water 45°C - Nominal flow rate.
- ❺ Total sound power level in dB(A) based on measurements carried out in accordance with regulation UNI EN-ISO 9614.
- Ⓟ Weight refers to the unit when empty.
- (∅) In Average climatic conditions, low temperature application
- (§) Seasonal energy efficiency: low temperature application in Average climate (EU Regulations N°811/2013 and N°813/2013)

Z-Power EXP

TXAVZ 2420÷2700

Cooling capacity: 408÷698 kW - Heating capacity: 413÷707 kW



TXAVSZ 2550

TXAVSZ 2700



• T.E.R. * up to 8.33

EXPsystems - Multi-purpose ecological air-cooled system with axial fans.
Range with semi-hermetic screw compressors and R134a refrigerant gas.

Construction features

- Compressor: high energy efficiency semi-hermetic screw compressor, with star-delta limited start and complete with integral protection, casing heater, refrigerant gas intake and outlet piping shut-off valve and compressor oil level sensor.
- Main and secondary heat exchangers: dry expansion shell and tube with counterflow heat exchange, complete with antifreeze heater, closed cell polyurethane foam rubber insulation, water flow differential pressure switch and Victaulic fittings.
- Air side heat exchanger: finned coil with copper pipes and aluminium fins.
- Fan: external rotor axial type electric fans, equipped with internal thermal protection, accident protection grilles and a proportional electronic device for continuous fan rotation speed regulation.
- Control: microprocessor electronic control.
- Structure: made of galvanised and painted steel plate with polyester powder coating
- The unit is also complete with:
 - display of cooling circuit high/low pressure;
 - clock board;
 - electronic expansion valve.

Versions

- B - Standard version (TXAVBZ).
- S - Silenced version with lower speed fans and soundproofed compressor cover (TXAVSZ).
- I - Soundproofed version with soundproofed compressor cover (TXAVIZ).

Models

- TXAVBZ: standard EXPsystems unit.
- TXAVSZ: silenced EXPsystems unit.
- TXAVIZ: soundproof EXPsystems unit.

Factory fitted accessories

- -15°C condensation control with fans with EC motor.
- Power factor correction capacitors ($\cos\phi > 0.94$).
- Compressor and fan thermal overload switches.
- Forced limit of power consumption.
- Coil protection grilles.
- Bottom compartment protection grilles.
- Digital input for double set-point.
- Low and high pressure gauges for each refrigerant circuit.
- Electrical panel resistance
- Control of min/max power supply voltage.
- 4-20 mA analogue input for shifting set-point.
- Copper/pre-painted aluminium or copper/copper coils.
- Interfaces for serial communication with other devices.
- Spring antivibration mountings.

Separately supplied accessories

- Remote keypad with display.
- Rhoss supervisors for unit monitoring and remote management.
- Rhoss sequencer for integrated management of several water chillers.



TXAVBZ MODEL		2420	2480	2550	2610	2700	
❶	Nominal cooling capacity (AUTOMATIC 1)	kW	425	482	555	617	698
❷	Recovery heating capacity (AUTOMATIC 2)	kW	545	622	709	786	888
❸	Nominal heating capacity (SELECT 1-2 AUTOMATIC 3)	kW	430	490	568	625	707
❹	Absorbed power (AUTOMATIC 1)	kW	143,8	165,3	179,2	198,4	224,1
❺	Absorbed power (AUTOMATIC 2)	kW	121	142	155,8	170,7	190,9
❻	Absorbed power (SELECT 1-2 AUTOMATIC 3)	kW	141,1	158,8	177,7	194,8	220,8
	E.E.R. (AUTOMATIC 1)		2,96	2,92	3,1	3,11	3,11
	T.E.R. (AUTOMATIC 2)		8,03	7,79	8,13	8,24	8,33
	C.O.P. (SELECT 1-2 AUTOMATIC 3)		3,05	3,09	3,2	3,21	3,2
Ⓢ	Sound pressure	dB(A)	65	65	65	66	67
Ⓣ	Sound power	dB(A)	98	98	98	99	99
TXAVSZ MODEL		2420	2480	2550	2610	2700	
❶	Nominal cooling capacity (AUTOMATIC 1)	kW	408	463	533	592	670
❷	Recovery heating capacity (AUTOMATIC 2)	kW	545	622	709	786	888
❸	Nominal heating capacity (SELECT 1-2 AUTOMATIC 3)	kW	413	470	545	600	679
❹	Absorbed power (AUTOMATIC 1)	kW	143,1	164,5	178,3	197,4	223
❺	Absorbed power (AUTOMATIC 2)	kW	121	142	155,8	170,7	190,9
❻	Absorbed power (SELECT 1-2 AUTOMATIC 3)	kW	141,1	158	176,8	193,8	219,7
	E.E.R. (AUTOMATIC 1)		2,85	2,81	2,99	3	3
	C.O.P. (SELECT 1-2 AUTOMATIC 3)		2,93	2,97	3,08	3,1	3,09
Ⓢ	Sound pressure	dB(A)	59	59	59	60	61
Ⓣ	Sound power	dB(A)	92	92	92	93	93
MODEL TXAVBZ-TXAVIZ SEASONAL PERFORMANCE IN HEATING MODE							
(∇)	P _{design} (EN 14825)	kW	346	394	-	-	-
(∇)	SCOP (EN 14825)		3,12	3,17	-	-	-
(§)	η _s	%	122	124	-	-	-
MODEL TXAVSZ SEASONAL PERFORMANCE IN HEATING MODE							
(∇)	P _{design} (EN 14825)	kW	332	378	-	-	-
(∇)	SCOP (EN 14825)		3,04	3,1	-	-	-
(§)	η _s	%	119	121	-	-	-
MODEL		2420	2480	2550	2610	2700	
	Screw/step compressor	no.	2/6	2/6	2/6	2/6	2/6
	Circuits	no.	2	2	2	2	2
	Electrical supply	V-ph-Hz	400-3-50	400-3-50	400-3-50	400-3-50	400-3-50
TXAVBZ-TXAVSZ DIMENSIONS AND WEIGHT							
	L - Width	mm	6130	6130	6130	6980	7980
	H - Height	mm	2430	2430	2430	2430	2430
	P - Depth	mm	2260	2260	2260	2260	2260
Ⓣ	TXAVBZ weight	kg	5530	6300	6360	7460	8380

Data at the following conditions:

- ❶ Air: 35°C - Water: 12/7°C.
- ❷ Air: 7°C D.B. - 6°C W.B. - Water: 40/45°C.
- ❸ In open field (Q = 2) at 10 m from the unit.
- ❹ Evaporator water: 12/7°C. Recovery output water 45°C - Nominal flow rate.

Ⓣ Empty weight.

Ⓣ Total sound power level in dB(A) based on measurements carried out in accordance with regulation UNI EN-ISO 9614.

(∇) In Average climatic conditions, low temperature application

(§) Seasonal energy efficiency: low temperature application in Average climate (EU Regulations N°811/213 and N°813/2013)

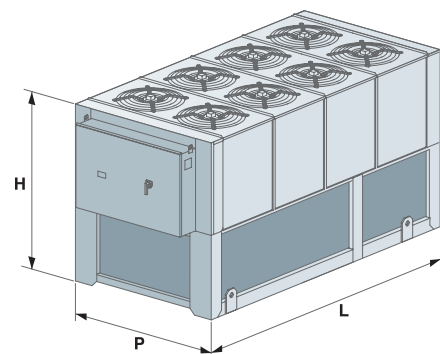

Low consumption Comby-Flow EXP

TXHEY 105÷112

Cooling capacity: 5.5÷12.2 kW - Heating capacity: 6.4÷13.7 kW



EXPsystems - Polyvalent ecological water cooled system. Range with hermetic Scroll compressors and R410A refrigerant gas.

Construction features

- Compressor: hermetic, rotary scroll type, complete with thermal protection.
- Primary side (user) and secondary side (recovery) heat exchanger and disposal unit: suitably insulated stainless steel plates, complete with antifreeze heater and water flow differential pressure switch.
- Control: microprocessor electronic control, iDRHOSS compatible with AdaptiveFunction logic.
- Condensation control: pressure switch valve and bypass solenoid valve.
- Structure: made of galvanised and painted sheet steel with polyester powder coating, complete with soundproofed compressor.

Models

- TXHEY: EXPsystems unit.

PUMP setup

- Primary side (user): pump unit complete with circulation electric pump, membrane expansion tank, safety valve, water drain valve, manual air bleed valve and pressure gauge.
- Well/tower side (disposal unit): drain valve and bleed valve. Internal tap for primary side system supply (user) from external network (disposal unit side: well or tower).
- Secondary side (recovery): pump unit complete with electric circulation pump, membrane expansion tank, safety valve, water fill and drain valve, manual air bleed valve and pressure gauge.

Factory fitted accessories

- Digital input for double set-point.
- 4-20mA analogue input for shifting set-point.

Separately supplied accessories

- Buffer tank.
- Buffer tank connection pipes.
- Water filter.
- Rubber anti-vibration mountings.
- Antifreeze heater on the buffer tank.
- Remote keypad with display.
- Clock board.
- Interfaces for serial communication with other devices.
- RS485/USB serial converter.
- Rhoss supervisors for unit monitoring and remote management.

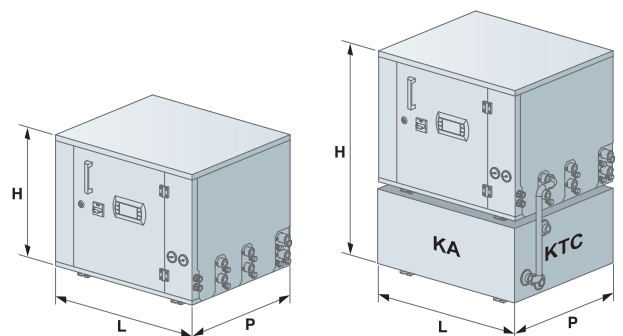



TXHEY MODEL		105	107	109	112
Radiant systems					
❶ Cooling capacity (AUTOMATIC 1)	kW	7,8	10,6	13,8	18
❷ Recovery heating capacity (AUTOMATIC 2)	kW	8,7	10,7	14,7	18,8
❸ Heating capacity (SELECT 1-2 AUTOMATIC 3)	kW	7,6	9,8	12,8	15,1
Fan coil systems					
❹ Nominal cooling capacity (AUTOMATIC 1)	kW	5,5	6,9	9,5	12,2
❺ Recovery heating capacity (AUTOMATIC 2)	kW	6,7	8,7	11,3	14,5
❻ Nominal heating capacity (SELECT 1-2 AUTOMATIC 3)	kW	6,4	8,1	10,6	13,7
❼ Absorbed power (*) (AUTOMATIC 1)	kW	1,69	2,22	2,91	3,74
❽ Absorbed power (*) (AUTOMATIC 2)	kW	2	2,83	3,57	4,75
❾ Absorbed power (*) (SELECT 1-2 AUTOMATIC 3)	kW	1,93	2,8	3,33	4,21
❿ T.E.R. (AUTOMATIC 2)		5,72	5,14	5,42	5,67
TXHEY MODEL SEASONAL PERFORMANCE IN HEATING MODE					
(◊) Pdesign (EN 14825)	kW	9	12	15	18
(◊) SCOP (EN 14825)		4,36	4,97	4,78	4,71
(§) η_s	%	166	191	183	180
(§) Energy class		A++	A++	A++	A++
❼ Sound pressure	dB(A)	49	51	51	53
Scroll/step compressor	no.	1/1	1/1	1/1	1/1
Circuits	no.	1	1	1	1
KA Buffer tank water content	l	20	20	30	30
❼ Available nominal head of pump on main heat exchanger	kPa	47	54,7	82,2	78,2
❽ Available nominal head on secondary recovery heat exchanger	kPa	32,4	42,4	72,1	66,7
Electrical supply	V-ph-Hz	230-1-50	230-1-50 / 400-3+N-50	230-1-50 / 400-3+N-50	230-1-50 / 400-3+N-50
DIMENSIONS AND WEIGHTS					
L - Width	mm	585	585	660	660
H - TXHEY P height	mm	535	535	535	535
H - TXHEY P + KA height	mm	855	855	855	855
P - Depth	mm	520	520	560	560
TXHEY Weight	kg	112	118	122	130
KA Weight	kg	38	38	43	43

Data at the following conditions:

- ❶ Chilled water: 23/18°C - Condenser water: 30/35°C
- ❷ Chilled water: 23/18°C - Recovery water: 40/45°C
- ❸ Hot water: 30/35°C. Evaporator water: 10/7°C.
- ❹ Chilled water: 12/7°C - Condenser water: 30/35°C
- ❺ Chilled water: 12/7°C - Recovery water: 40/45°C.
- ❻ Hot water: 40/45°C. Evaporator water: 10/7°C.
- ❼ In open field (Q = 2) at 1 m from the unit.

(*) Unit without electric pumps.

Performance according to EN 14511:2013

T.E.R.: Total efficiency ratio

KA = buffer tank.

KTC = connecting pipe.

(◊) In Average climatic conditions, low temperature application

(§) Seasonal energy efficiency: low temperature application in Average climate (EU Regulations N°811/2013 and N°813/2013)

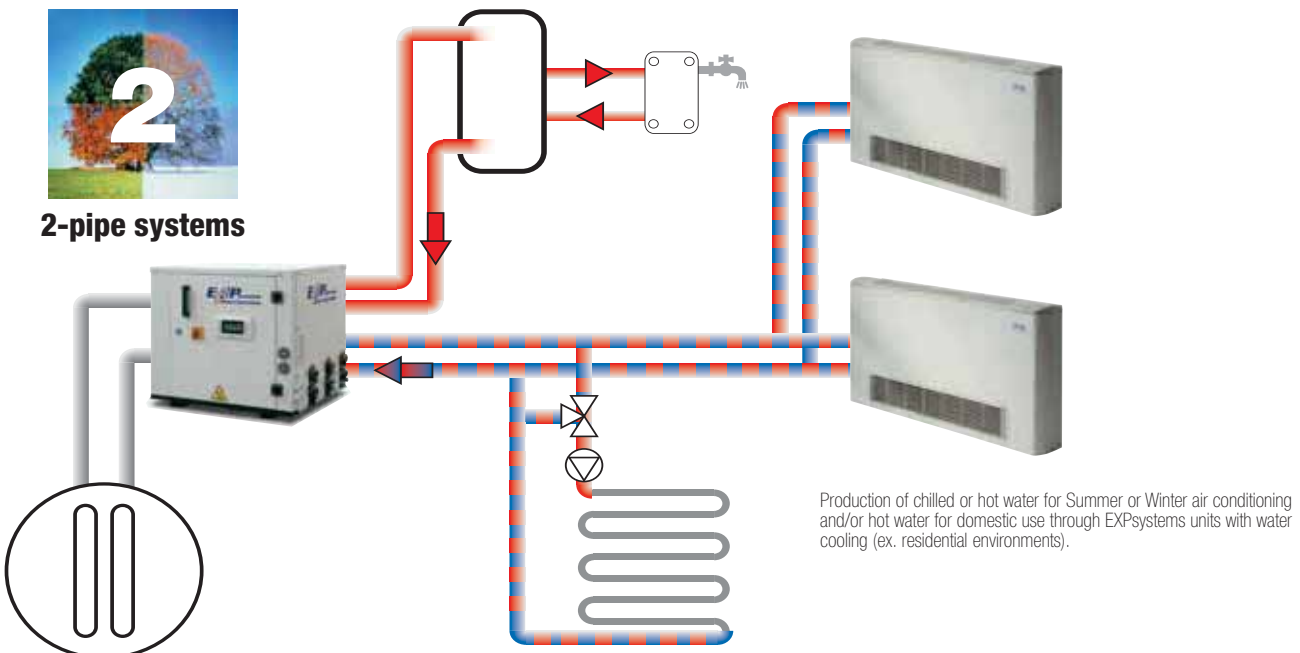

Low consumption Y-Flow EXP TXHEY 245÷4450

Cooling capacity: 47÷462.6 kW - Heating capacity: 54÷552.6 kW



EXPsystems - Polyvalent ecological water cooled system.
Range with hermetic Scroll compressors and R410A refrigerant gas.

Construction features

- Compressor: scroll type, rotary, hermetic complete with thermal protection and casing heater.
- Primary side (user), secondary side (recovery) heat exchangers and disposal unit: cross-flow stainless steel plate exchangers, complete with antifreeze heater, closed cell polyurethane foam rubber insulation and water flow differential pressure switch.
- Control: microprocessor electronic control with Adaptive Function Plus logic.
- Structure: made of galvanised and painted steel plate with polyester powder coating.
- The unit is also complete with:
 - compressor circuit breaker switches,
 - electronic expansion valve,
 - display of cooling circuit high and low pressure,
 - clock board,
 - outdoor temperature probe for set-point compensation,
 - 0-10V analogue signal for condensing/evaporating control performed by external device.

Versions

- B - Standard version.

Models

- TXHEY: EXPsystems unit.

Factory fitted accessories

- Cooling circuit high and low pressure gauges.
- Forced limit of power consumption.
- Soft starter.
- Silenced set up.
- Digital input for double set-point.
- 4-20 mA analogue input for shifting set-point.
- Interfaces for serial communication with other devices.
- Anti-vibration mounts.

Separately supplied accessories

- 3-way modulating condensing control valve.
- 2-way modulating condensing control valve.
- Water filter.
- Remote keypad with display.
- Thermostat with display.
- RS485/USB serial converter.
- RHSS supervisors for unit monitoring and remote management.
- Rhoss sequencer for integrated management of several water chillers.





TXHEBY MODEL		245	250	260	270	290	2115	2130	2145	2165	2185
❶ Nominal cooling capacity (AUTOMATIC 1)	kW	47	55,6	62,7	71,8	92,8	123,8	137,5	153,9	173,3	193,2
❷ Recovery heating capacity (AUTOMATIC 2)	kW	50,6	59,6	68,5	76,2	102,9	134,9	148,9	164,8	187,8	211,1
❸ Nominal heating capacity (SELECT 1-2 AUTOMATIC 3)	kW	54	63,6	73,1	81,3	109,8	143,7	158,6	175,8	200,5	225,5
❹ Total absorbed power (AUTOMATIC 1)	kW	8,5	9,8	11,3	13	16,9	21,5	24,7	26,7	31,8	36,3
❺ Total absorbed power (AUTOMATIC 2)	kW	12	13,7	15,7	17,4	23,4	31,1	34,9	38,9	45,3	51,4
❻ Total absorbed power (SELECT 1-2 AUTOMATIC 3)	kW	12	13,8	15,7	17,4	23,5	31	34,8	38,9	45,3	51,3
❼ E.E.R. (AUTOMATIC 1)		5,51	5,69	5,55	5,51	5,48	5,75	5,57	5,76	5,44	5,32
❽ C.O.P. (SELECT 1-2 AUTOMATIC 3)		4,5	4,63	4,65	4,67	4,67	4,63	4,55	4,52	4,43	4,39
❾ T.E.R. (AUTOMATIC 2)		7,5	7,7	7,8	7,8	7,8	7,7	7,6	7,5	7,3	7,2

TXHEBY MODEL SEASONAL PERFORMANCE IN HEATING MODE

(∅) Pdesign (EN 14825)	kW	59	69	80	89	119	156	173	191	218	245
(∅) SCOP (EN 14825)		5,90	6,10	6,22	6,11	6,01	6,43	6,31	6,31	6,09	5,88
(§) η_s	%	228	236	241	236	232	249	245	244	235	227
(§) Energy class		A++	A++	-	-	-	-	-	-	-	-

TXHEBY MODEL		245	250	260	270	290	2115	2130	2145	2165	2185
❺ Sound power	dB(A)	67	67	68	68	70	72	73	74	74	75
Scroll/step compressor	no.	2/2	2/2	2/2	2/2	2/2	2/2	2/2	2/2	2/2	2/2
Circuits	no.	1	1	1	1	1	1	1	1	1	1
Electrical supply	V-ph-Hz	400-3+N-50	400-3+N-50	400-3+N-50	400-3+N-50	400-3+N-50	400-3+N-50	400-3+N-50	400-3+N-50	400-3+N-50	400-3+N-50

DIMENSIONS AND WEIGHTS		245	250	260	270	290	2115	2130	2145	2165	2185
L - Width	mm	1020	1020	1020	1020	1020	1270	1270	1270	1270	1270
H - Height	mm	1470	1470	1470	1470	1470	1620	1620	1620	1620	1620
P - Depth	mm	870	870	870	870	870	870	870	870	870	870
❻ Weight	kg	510	525	540	565	595	920	960	995	1035	1045

TXHEBY MODEL		4180	4205	4235	4260	4290	4330	4360	4410	4450
❶ Nominal cooling capacity (AUTOMATIC 1)	kW	188,5	214,7	241,2	270,2	302,7	341,1	379,9	420,9	462,6
❷ Recovery heating capacity (AUTOMATIC 2)	kW	202,4	231,2	259,5	292,5	325,2	370,2	416,1	466,3	516,4
❸ Nominal heating capacity (SELECT 1-2 AUTOMATIC 3)	kW	216	246,8	277	313,2	347,9	398	447,3	499,1	552,6
❹ Total absorbed power (AUTOMATIC 1)	kW	32,2	37,2	41,9	46,6	50,4	59,1	67,2	78,9	90,4
❺ Total absorbed power (AUTOMATIC 2)	kW	43,4	50,5	57,7	64,8	71,8	83,1	94,2	107,5	120,9
❻ Total absorbed power (SELECT 1-2 AUTOMATIC 3)	kW	43,3	50,5	57,6	64,8	72	83,3	94,5	108	121,6
❼ E.E.R. (AUTOMATIC 1)		5,85	5,77	5,76	5,8	6,01	5,77	5,65	5,33	5,12
❽ C.O.P. (SELECT 1-2 AUTOMATIC 3)		4,98	4,89	4,81	4,83	4,84	4,77	4,73	4,62	4,55
❾ T.E.R. (AUTOMATIC 2)		8,4	8,2	8	8,1	8,1	7,9	7,9	7,7	7,6

TXHEBY MODEL SEASONAL PERFORMANCE IN HEATING MODE

(∅) Pdesign (EN 14825)	kW	234	267	300	340	379	-	-	-	-
(∅) SCOP (EN 14825)		6,73	6,63	6,51	6,57	6,66	-	-	-	-
(§) η_s	%	261	257	253	255	258	-	-	-	-

TXHEBY MODEL		4180	4205	4235	4260	4290	4330	4360	4410	4450
❺ Sound power	dB(A)	77	77	78	79	80	81	82	83	84
Scroll/step compressor	no.	4/4	4/4	4/4	4/4	4/4	4/4	4/4	4/4	4/4
Circuits	no.	2	2	2	2	2	2	2	2	2
Electrical supply	V-ph-Hz	400-3-50	400-3-50	400-3-50	400-3-50	400-3-50	400-3-50	400-3-50	400-3-50	400-3-50

DIMENSIONS AND WEIGHTS		4180	4205	4235	4260	4290	4330	4360	4410	4450
L - Width	mm	2600	2600	2600	2600	2600	2600	2600	2600	2600
H - Height	mm	1860	1860	1860	1860	1860	1860	1860	1860	1860
P - Depth	mm	870	870	870	870	870	870	870	870	870
❻ Weight	kg	1690	1730	1780	1820	1890	1960	2000	2070	2100

Data at the following conditions:

- ❶ Chilled water (user): 12/7°C - Condenser water (disposal unit-source): 14/30°C.
- ❷ Chilled water (user): 12/7°C - Condenser water (recovery unit): 40/45°C.
- ❸ Evaporator water (source): 14/10°C - Hot water (utility): 40/45°C.
- ❹ Total sound power level in dB(A) based on measurements carried out in accordance with regulation UNI EN-ISO 9614.
- ❺ Empty weight
- (∅) In Average climatic conditions, low temperature application
- (§) Seasonal energy efficiency: low temperature application in Average climate (EU Regulations N°81/1/213 and N°813/2013)

Z-Flow EXP

TXHVZ 2410÷2740

Cooling capacity: 434÷782 kW - Heating capacity: 482÷878 kW



TXHVZ 2740

EXPsystems - Polyvalent ecological water cooled system.

Range with semi-hermetic screw compressors and R134a refrigerant gas.

Construction features

- Compressor: high energy efficiency semi-hermetic screw compressor, with star-delta limited start and complete with integral protection, casing heater, refrigerant gas intake and outlet piping shut-off valve and compressor oil level sensor.
- Primary side (user), secondary side (recovery) heat exchanger and disposal unit: dry expansion shell and tube, complete with antifreeze heater, closed cell polyurethane foam rubber insulation, water flow differential pressure switch and Victaulic fittings.
- Control: microprocessor electronic control.
- Structure: made of galvanised and painted steel plate with polyester powder coating.
- The unit is also complete with:
 - display of cooling circuit high and low pressure;
 - clock board;
 - electronic expansion valve.

Versions

- B - Standard version (TXHVBZ).
- I - Soundproofed version with soundproofed compressor cover (TXHVIZ).

Models

- TXHVBZ: standard EXPsystems unit.
- TXHVIZ: soundproof EXPsystems unit.

Factory fitted accessories

- Power factor capacitors ($\cos\phi > 0.94$).
- Soft starter
- Compressors MCBs.
- Forced limit of power consumption.
- Digital input for double set-point.
- Control of min/max power supply voltage.
- 4-20 mA analogue input for shifting set-point.
- Interfaces for serial communication with other devices.
- Spring antivibration mountings.

Separately supplied accessories

- Remote keyboard with display.
- Rhoss supervisors for unit monitoring and remote management.
- Rhoss sequencer for integrated management of several water chillers.





TXHVBZ - TXHVIZ MODEL		2410	2450	2500	2590	2660	2740
❶	Nominal cooling capacity (AUTOMATIC 1)	kW	434	476	531	626	782
❷	Nominal cooling capacity (AUTOMATIC 1)	kW	408	450	501	592	738
❸	Recovery heating capacity (AUTOMATIC 2)	kW	462	512	563	663	838
❹	Nominal heating capacity (SELECT 1-2 AUTOMATIC 3)	kW	482	539	589	694	878
❶	Total absorbed power (AUTOMATIC 1)	kW	78,8	87,6	92,8	107,2	138,2
❷	Total absorbed power (AUTOMATIC 1)	kW	86,6	96,4	101,8	119,6	151,0
❸	Total absorbed power (AUTOMATIC 2)	kW	104,6	116,2	122,5	143,8	181,7
❹	Total absorbed power (SELECT 1-2 AUTOMATIC 3)	kW	105,6	119,0	123,6	144,6	184,4
❶	E.E.R. (AUTOMATIC 1)		5,51	5,43	5,72	5,84	5,73
❷	E.E.R. (AUTOMATIC 1)		4,71	4,67	4,92	4,95	4,98
❷	T.E.R.		7,86	7,85	8,22	8,25	8,25
❹	C.O.P. (SELECT 1-2 AUTOMATIC 3)		4,56	4,53	4,77	4,80	4,81
TXHVBZ MODEL		2410	2450	2500	2590	2660	2740
❺	Sound power	dB(A)	97	97	98	99	99
	Screw/step compressor	no.	2/6	2/6	2/6	2/6	2/6
	Circuits	no.	2	2	2	2	2
	Electrical supply	V-ph-Hz	400-3-50	400-3-50	400-3-50	400-3-50	400-3-50
DIMENSIONS AND WEIGHTS		2410	2450	2500	2590	2660	2740
L - Width	mm	4.480	4.480	4.480	4.480	4.480	4.480
H - Height	mm	2.030	2.030	2.030	2.030	2.030	2.030
P - Depth	mm	1.620	1.620	1.620	1.620	1.620	1.620
	TXHVBZ Weight	kg	3.900	4.745	5.330	5.720	6.000
❻	TXHVIZ Weight	kg	4.020	4.865	5.450	5.840	6.140

Data at the following conditions:

- ❶ Chilled water (user): 12/7°C - Condenser water (disposal unit-source): 14/30°C.
- ❷ Chilled water (user): 12/7°C - Condenser water: 30/35°C.
- ❸ Chilled water (user): 12/7°C - Condenser water (recovery unit): 40/45°C.
- ❹ Evaporator water (source): 14°C - Water flow rate like in summer operation (❶). Hot water (utility): 40/45°C.
- ❺ Total sound power level in dB(A) based on measurements carried out in accordance with regulation UNI EN-ISO 9614.
- ❻ Empty weight.

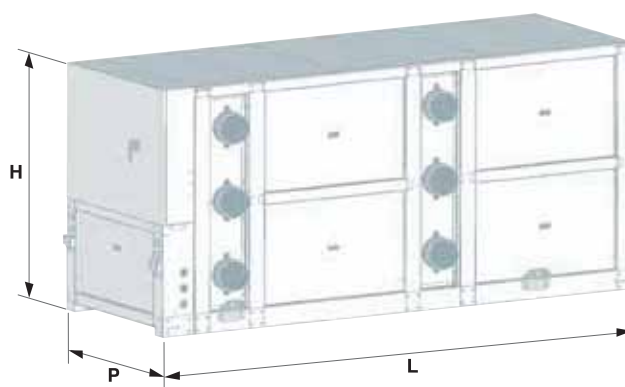



CONDENSING UNITS

Moto-condensing units

MCAEBY 115÷130

Cooling capacity: 16.4÷31.5 kW



Air-cooled condensing units with axial fans.
Range with hermetic compressors and R410A refrigerant gas.

Construction features

- Compressor: scroll type, hermetic complete with thermal protection and crankcase heater.
- Air side heat exchanger: featuring finned coil with copper pipes and aluminium fins, complete with protection grille.
- Fan: electric axial fans with external rotor, equipped with internal thermal protection, protection grilles and proportional electronic device for pressurised and continuous fan rotation speed regulation up to an outdoor air temperature of -10°C.
- Control: electronic with microprocessor.
- Structure: made of galvanised and painted sheet steel.

Models

- MCAEBY: unit intended for cooling only.

Factory fitted accessories

- Silenced set-up.

Accessories separately supplied

- Rubber vibration dampers.
- RS485 Interface for serial communication with other devices.
- RS485/USB serial converter.

MCAEBY MODEL		115	117	122	124	127	130
❶ Nominal cooling capacity	kW	16,4	18,5	24,7	26,5	29	31,5
❶ Absorbed power	kW	5,5	6,3	7,9	9	9,8	11
MCAEBY MODEL		115	117	122	124	127	130
❸ Sound pressure	dB(A)	50	50	52	52	53	53
Electrical supply	V-ph-Hz	400-3+N-50	400-3+N-50	400-3+N-50	400-3+N-50	400-3+N-50	400-3+N-50
DIMENSIONS AND WEIGHTS		115	117	122	124	127	130
L - Width	mm	1230	1230	1230	1230	1535	1535
H - Height	mm	1090	1090	1280	1280	1510	1510
P - Depth	mm	580	580	600	600	695	695
MCAEBY weight	kg	140	150	200	225	270	300

Data at the following conditions:

- ❶ Air: 35°C - Sucked saturated gas: 5°C.
- ❸ In open field (Q = 2) at 5 m from the unit.

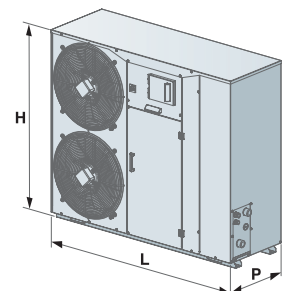

Moto-condensing units

MCAEBY 233÷2160

Cooling capacity: 34.5÷162.6 kW



Air-cooled moto-condensing units with axial fans. Range with hermetic Scroll compressors and R410A refrigerant gas.

Construction features

- Compressor: hermetic, rotary Scroll compressor, complete with thermal protection and casing heater.
- Air side heat exchanger: finned coil with copper pipes and aluminium fins.
- Fan: electric axial fans with external rotor, equipped with internal thermal protection, proportional electronic device for continuous fan rotation speed regulation and protection grilles.
- Control: microprocessor electronic control.
- Structure: in galvanised and painted sheet steel, with polyurethane powder coating.
- The unit is also complete with:
 - compressor and fan thermal overload switches,
 - R410A gas pre-load.

Models

- MCAEBY: unit designed for cooling only.

Factory fitted accessories

- Silenced set up
- Coil protection metal filters.
- Cooling circuit high and low pressure gauges.
- Liquid receiver.
- Copper/pre-painted aluminium or copper/copper coils.
- Rubber anti-vibration mountings.

Separately supplied accessories

- Thermostatic valve kit.
- Interfaces for serial communication with other devices.
- RS485/USB serial converter.

MCAEBY MODEL		233	238	245	250	260	265	280
❶ Nominal cooling capacity	kW	34,5	41,2	46,7	54,3	62,5	67,7	79,1
❶ Absorbed power	kW	12,5	14,7	17,6	19,9	22,4	24,3	28,4
MCAEBY MODEL		233	238	245	250	260	265	280
❸ Sound pressure	dB(A)	46,5	47	48	48	49	49	50
Electrical supply	V-ph-Hz	400-3+N-50	400-3+N-50	400-3+N-50	400-3+N-50	400-3+N-50	400-3+N-50	400-3+N-50
DIMENSIONS AND WEIGHTS		233	238	245	250	260	265	280
L - Width	mm	1710	2315	2315	2315	2315	2315	2650
H - Height	mm	1570	1570	1570	1570	1570	1570	1700
P - Depth	mm	1000	1000	1000	1000	1000	1000	1210
MCAEBY weight	kg	400	546	536	570	586	624	880

MCAEBY MODEL		290	2100	2115	2130	2145	2160
❶ Nominal cooling capacity	kW	87,1	101	116,2	126,5	145,6	162,6
❶ Absorbed power	kW	32,9	36,2	41,2	46,2	52,9	60,2
MCAEBY MODEL		290	2100	2115	2130	2145	2160
❸ Sound pressure	dB(A)	52	52	58	58	58	59
Electrical supply	V-ph-Hz	400-3+N-50	400-3+N-50	400-3+N-50	400-3+N-50	400-3+N-50	400-3+N-50
DIMENSIONS AND WEIGHTS		290	2100	2115	2130	2145	2160
L - Width	mm	3150	3150	3150	3150	3150	3450
H - Height	mm	1700	1700	1730	1730	1730	1700
P - Depth	mm	1210	1210	1210	1210	1210	1210
MCAEBY weight	kg	935	950	998	998	1052	1108

Data at the following conditions:

- ❶ Air: 35°C - Sucked saturated gas: 5°C.
- ❸ In open field (Q = 2) at 10 m from the unit.

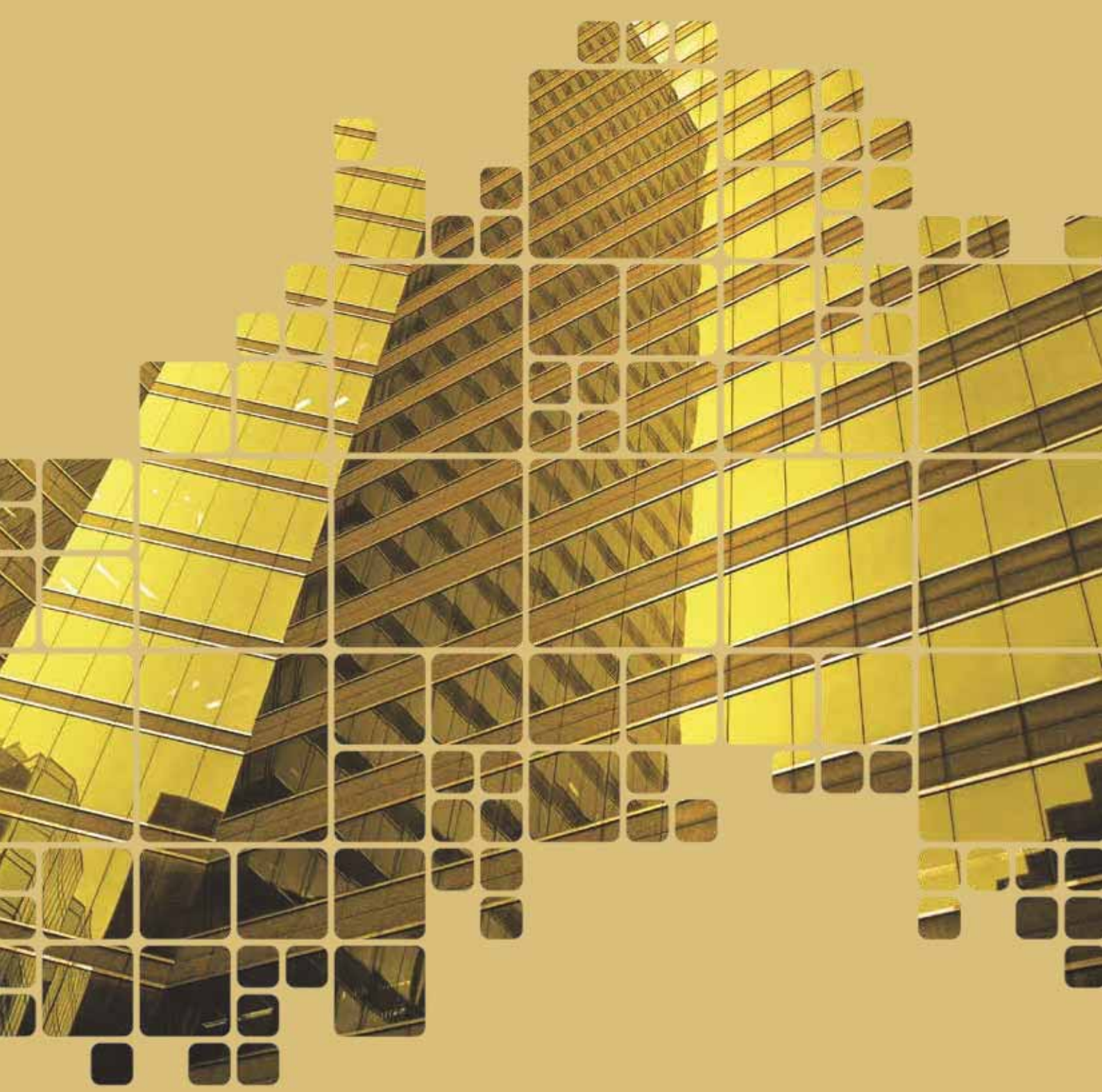

SYSTEM ACCESSORIES

Remote condensers

CCAMY 115÷2185



Vertical installation

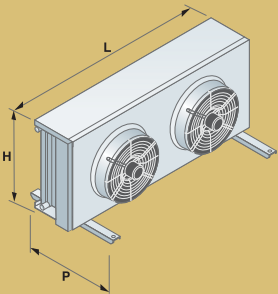

Horizontal installation

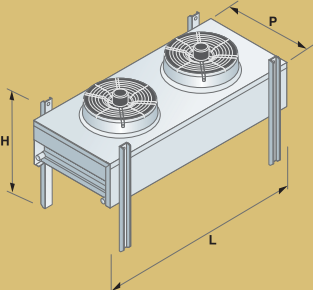

Vertical installation

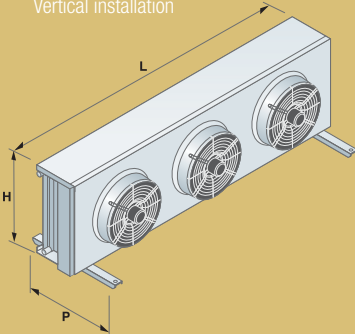

Horizontal installation

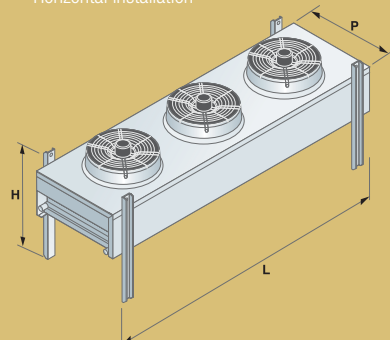

Remote air condensers with axial fans for direct expansion units operating with R410A refrigerant gas. To be combined with the TCEEY condenserless units.

Construction features

- Heat exchanger: high efficiency finned coil with copper pipes mechanically expanded on aluminium fins. The cooling connections need brazing. Projected pressure 40 barg. Every exchanger is tested for leakage with dry air and preloaded with nitrogen.
- Fans: external rotor axial type with fans equipped with innovative polymer material blades and integrated thermal protection that provides protection against thermal overload. IP54 degree of protection in compliance with DIN 40050. The fan series is also complete with phase cut speed control.
- Structure: in zinc-plated steel sheet pre-varnished with epoxy finish (RAL 9002). The battery structure is in aluminium alloy (AlMg3) to protect against vibrations and thermal dilatations. The condensers are supplied with support rod kits for vertical installation with horizontal air flow (CCAMY V) or horizontal with vertical air flow (CCAMY H). The support rods are made of zinc-plated steel

Electrical panel complete with:

- electrical wiring suited for 400V-3ph-50Hz power supply voltage;
- electrical supply junction box with disconnecting switch where the general power supply voltage of the remote condenser can be connected;
- self-extinguishing plastic casing (IP55) containing the fan rotation speed continuous control device, via a phase cut device,
- pressure probe,
- fan electrical wiring,
- contact for external signal of fan thermal intervention, remote on/off contact.

Versions

- The CCAMY range remote condensers are available in 3 construction options that meet the different system requirements regarding ambient noise emission containment:
 - Basic "B" version (except mod.115)
 - Version "S" Silenced
 - Version "Q" Super-silenced



CCAMBY MODEL		118	122	125	230	240	
VERSION B "Basic"							
① Nominal heating capacity	kW	22,8	25,55	29,37	39,88	48,96	
② Sound pressure	dB(A)	41	41	44	47	47	
Cooling circuits	no.	1	1	1	1	1	
Fans	no.	1	1	1	2	2	
Fans nominal flow rate	m³/h	6419	6068	7019	15560	14760	
Rotation speed	rpm	1180	1180	1390	1390	1390	
① Absorbed power	kW	0,55	0,55	0,72	1,44	1,44	
Electrical supply	V-ph-Hz	400-3-50	400-3-50	400-3-50	400-3-50	400-3-50	
DIMENSIONS AND WEIGHTS							
H horizontal installation							
L - Width	mm	1115	1115	1115	2015	2015	
H - Height	mm	846	846	846	846	846	
P - Depth	mm	868	868	868	868	868	
V vertical installation							
L - Width	mm	1115	1115	1115	2015	2015	
H - Height	mm	828	828	828	828	828	
P - Depth	mm	470	470	470	470	470	
Weight *	Kg	49	54	54	83	92	
CCAMSY MODEL							
VERSION S "Silenced"		115	118	122	125	230	240
① Nominal heating capacity	kW	18,96	20,76	29,08	33,9	36,94	48,9
② Sound pressure	dB(A)	36	36	36	36	39	41
Cooling circuits	no.	1	1	1	1	1	1
Fans	no.	1	1	2	2	2	3
Fans nominal flow rate	m³/h	4865	4599	9224	8643	9730	15510
Rotation speed	rpm	930	930	800	800	930	930
① Absorbed power	kW	0,27	0,27	0,38	0,38	0,54	0,81
Electrical supply	V-ph-Hz	400-3-50	400-3-50	400-3-50	400-3-50	400-3-50	400-3-50
DIMENSIONS AND WEIGHTS							
H horizontal installation							
L - Width	mm	1115	1115	2015	2015	2015	2915
H - Height	mm	846	846	846	846	846	846
P - Depth	mm	868	868	868	868	868	868
V vertical installation							
L - Width	mm	1115	1115	2015	2015	2015	2915
H - Height	mm	828	828	828	828	828	828
P - Depth	mm	470	470	470	470	470	470
Weight *	Kg	49	54	83	92	92	121
CCAMQY MODEL							
VERSION Q "Super-silenced"		115	118	122	125	230	240
① Nominal heating capacity	kW	18,89	21,02	25,83	30,65	37,83	50
② Sound pressure	dB(A)	33	34	34	34	36	38
Cooling circuits	no.	1	1	1	1	1	1
Fans	no.	1	1	1	1	2	3
Fans nominal flow rate	m³/h	4071	7285	6724	6262	8141	12800
Rotation speed	rpm	800	690	690	690	800	800
① Absorbed power	kW	0,19	0,4	0,4	0,4	0,38	0,57
Electrical supply	V-ph-Hz	400-3-50	400-3-50	400-3-50	400-3-50	400-3-50	400-3-50
DIMENSIONS AND WEIGHTS							
H horizontal installation							
L - Width	mm	1115	1261	1261	1261	2015	2915
H - Height	mm	846	1171	1171	1171	846	846
P - Depth	mm	868	1100	1100	1100	868	868
V vertical installation							
L - Width	mm	1115	1261	1261	1261	2015	2915
H - Height	mm	828	1034	1034	1034	828	828
P - Depth	mm	470	750	750	750	470	470
Weight *	Kg	54	78	85	94	101	135

Data at the following conditions:

① Outdoor air temperature 35°C D.B., condensation temperature 50°C (dew point), desuperheating 25°K. Maximum speed

② In open field (Q = 2) at 10 m from the unit.

* Empty weight

Sound pressure level correction for distances other than 10m

Distance	(m)	2	3	4	5	7	10	15	20
Correction	dB(A)	11	8,5	7	5	2,5	0	-3	-5,5

Remote condensers

CCAMY 115÷2185

CCAMBY MODEL		245	250	260	270	275	290
VERSION B "Basic"							
❶ Nominal heating capacity	kW	56,92	74	76,34	80,16	87,39	108,49
❷ Sound pressure	dB(A)	47	49	49	50	51	53
Cooling circuits	no.	1	1	1	1	1	1
Fans	no.	2	3	3	4	2	3
Fans nominal flow rate	m³/h	14040	22100	22130	31130	21160	33100
Rotation speed	rpm	1390	1390	1390	1390	1330	1330
❶ Absorbed power	kW	1,44	2,16	2,16	2,88	2,5	3,75
Electrical supply	V-ph-Hz	400-3-50	400-3-50	400-3-50	400-3-50	400-3-50	400-3-50
DIMENSIONS AND WEIGHTS							
H horizontal installation							
L - Width	mm	2015	2915	2915	3815	2261	3261
H - Height	mm	846	846	846	846	1171	1171
P - Depth	mm	868	868	868	868	1100	1100
V vertical installation							
L - Width	mm	2015	2915	2915	3815	2261	3261
H - Height	mm	828	828	828	828	1034	1034
P - Depth	mm	470	470	470	470	750	750
Weight *	Kg	101	136	140	174	169	237
CCAMSY MODEL							
VERSION S "Silenced"							
❶ Nominal heating capacity	kW	53,99	69,69	74,74	92,21	95,37	106,28
❷ Sound pressure	dB(A)	46	46	46	47	49	49
Cooling circuits	no.	1	1	1	1	1	1
Fans	no.	3	3	3	4	3	3
Fans nominal flow rate	m³/h	20480	19260	18210	25670	27190	25690
Rotation speed	rpm	1180	1180	1180	1180	1070	1070
❶ Absorbed power	kW	1,65	1,65	1,65	2,2	2,52	2,52
Electrical supply	V-ph-Hz	400-3-50	400-3-50	400-3-50	400-3-50	400-3-50	400-3-50
DIMENSIONS AND WEIGHTS							
H horizontal installation							
L - Width	mm	2915	2915	2915	3815	3261	3261
H - Height	mm	846	846	846	846	1171	1171
P - Depth	mm	868	868	868	868	1100	1100
V vertical installation							
L - Width	mm	2915	2915	2915	3815	3261	3261
H - Height	mm	828	828	828	828	1034	1034
P - Depth	mm	470	470	470	470	750	750
Weight *	Kg	121	136	149	193	237	257
CCAMQY MODEL							
VERSION Q "Super-silenced"							
❶ Nominal heating capacity	kW	52,99	63,91	77,91	83,27	94,29	105
❷ Sound pressure	dB(A)	38	41	42	42	44	45
Cooling circuits	no.	1	1	1	1	1	1
Fans	no.	3	3	4	4	3	4
Fans nominal flow rate	m³/h	12960	13800	19460	18400	25490	33800
Rotation speed	rpm	800	930	930	930	890	890
❶ Absorbed power	kW	0,57	0,81	1,08	1,08	1,8	2,4
Electrical supply	V-ph-Hz	400-3-50	400-3-50	400-3-50	400-3-50	400-3-50	400-3-50
DIMENSIONS AND WEIGHTS							
H horizontal installation							
L - Width	mm	2915	2915	3815	3815	3261	4261
H - Height	mm	846	846	846	846	1171	1171
P - Depth	mm	868	868	868	868	1100	1100
V vertical installation							
L - Width	mm	2915	2915	3815	3815	3261	4261
H - Height	mm	828	828	828	828	1034	1034
P - Depth	mm	470	470	470	470	750	750
Weight *	Kg	140	149	192	210	216	274

Data at the following conditions:

❶ Outdoor air temperature 35°C D.B., condensation temperature 50°C (dew point), desuperheating 25°K. Maximum speed

❷ In open field (Q = 2) at 10 m from the unit.

* Empty weight

CCAMBY MODEL		2100	2115	2130	2145	2165	2185
VERSION B "Basic"							
❶ Nominal heating capacity	kW	123,65	135	149	169,23	200,8	217,23
❷ Sound pressure	dB(A)	53	54	54	54	55	56
Cooling circuits	no.	1	1	1	1	1	1
Fans	no.	3	4	4	4	5	6
Fans nominal flow rate	m³/h	31730	44140	44240	42310	52920	66210
Rotation speed	rpm	1330	1330	1330	1330	1330	1330
❶ Absorbed power	kW	3,75	5	5	5	6,25	7,5
Electrical supply	V-ph-Hz	400-3-50	400-3-50	400-3-50	400-3-50	400-3-50	400-3-50
DIMENSIONS AND WEIGHTS							
H horizontal installation							
L - Width	mm	3261	4261	4261	4261	5261	6261
H - Height	mm	1171	1171	1171	1171	1171	1171
P - Depth	mm	1100	1100	1100	1100	1100	1100
V vertical installation							
L - Width	mm	3261	4261	4261	4261	5261	6261
H - Height	mm	1034	1034	1034	1034	1034	1034
P - Depth	mm	750	750	750	750	750	750
Weight *	Kg	257	302	310	327	421	451
CCAMSY MODEL							
VERSION S "Silenced"							
❶ Nominal heating capacity	kW	130,58	135	149	173,43	190,91	212,68
❷ Sound pressure	dB(A)	50	50	50	51	52	52
Cooling circuits	no.	1	1	1	1	1	1
Fans	no.	4	4	4	5	6	6
Fans nominal flow rate	m³/h	36250	34100	34250	42820	54380	51380
Rotation speed	rpm	1070	1070	1070	1070	1070	1070
❶ Absorbed power	kW	3,36	3,36	3,36	4,2	5,04	5,04
Electrical supply	V-ph-Hz	400-3-50	400-3-50	400-3-50	400-3-50	400-3-50	400-3-50
DIMENSIONS AND WEIGHTS							
H horizontal installation							
L - Width	mm	4261	4261	4261	5261	6261	6261
H - Height	mm	1171	1171	1171	1171	1171	1171
P - Depth	mm	1100	1100	1100	1100	1100	1110
V vertical installation							
L - Width	mm	4261	4261	4261	5261	6261	6261
H - Height	mm	1034	1034	1034	1034	1034	1034
P - Depth	mm	750	750	750	750	750	750
Weight *	Kg	302	327	335	421	451	488
CCAMQY MODEL							
VERSION Q "Super-silenced"							
❶ Nominal heating capacity	kW	125	138,65	160	176	195,63	217,63
❷ Sound pressure	dB(A)	45	45	46	46	47	47
Cooling circuits	no.	1	1	1	1	1	1
Fans	no.	4	4	5	5	6	6
Fans nominal flow rate	m³/h	33990	32110	40000	40130	47900	48160
Rotation speed	rpm	890	890	890	890	890	890
❶ Absorbed power	kW	2,4	2,4	3	3	3,6	3,6
Electrical supply	V-ph-Hz	400-3-50	400-3-50	400-3-50	400-3-50	400-3-50	400-3-50
DIMENSIONS AND WEIGHTS							
H horizontal installation							
L - Width	mm	4261	4261	5261	5261	6261	6261
H - Height	mm	1171	1171	1171	1171	1171	1171
P - Depth	mm	1100	1100	1100	1100	1100	1100
V vertical installation							
L - Width	mm	4261	4261	5261	5261	6261	6261
H - Height	mm	1034	1034	1034	1034	1034	1034
P - Depth	mm	750	750	750	750	750	750
Weight *	Kg	274	299	383	383	443	450

Data at the following conditions:

- ❶ Outdoor air temperature 35°C D.B., condensation temperature 50°C (dew point), desuperheating 25°K. Maximum speed
- ❷ In open field (Q = 2) at 10 m from the unit.
- * Empty weight

Cooling towers

CEHV CEHP 46÷2791



- Wide range of models up to 2,800 kW
- Silenced version with considerable noise reduction
- Compact easy to install units

Cooling towers for water chillers with water condensation. Axial fans range.

Construction features

- The fan series is also complete with phase cut speed control.
- The battery structure is in aluminium alloy (AlMg3) to protect against vibrations and thermal dilatations.
- Drop separators: made of plastic.
- Fan: direct coupling axial fan with protection grille.
- Drain pan: in polyester resin strengthened with fibreglass complete with spray protection fins, drain connections, float re-integration and overflow.
- Structure: in polyester resin strengthened with fibreglass and load-bearing with an inspection pothole for models of the CEHV range; with hot-galvanised steel sections and with lateral damping using 22mm sandwich panels in polyester resin strengthened with fibreglass and a manhole for models of the CEHP-CEHPS range.

Models

- CEHV 46÷639 Cooling towers with load-bearing polyester resin structure strengthened with fibreglass.
- CEHP 744÷2791 Cooling towers with hot-galvanised steel sections and with lateral damping using 22mm sandwich panels in polyester resin strengthened with fibreglass.
- CEHPS 744÷2791 Silenced cooling towers with hot-galvanised steel sections and with lateral damping using 22mm sandwich panels in polyester resin strengthened with fibreglass.

Factory fitted accessories CEHV Range

- Anti-freeze electrical heater on condensation drain pan complete with minimum level switch.

CEHP - CEHPS range

- Removable side wall.
- Anti-freeze electrical heater on condensation drain pan complete with minimum level switch.



CEHV MODEL		46	87	105	139	169	203	238	337	395	477	506	599	639
① Nominal heating capacity consumption	kW	46,5	87,2	104,7	139,5	168,6	203,5	238,4	337,2	395,3	476,7	505,8	598,8	639,5
Installed fan electrical power	kW	0,55	0,75	0,75	1,1	1,1	1,1	1,1	2,2	2,2	4	4	4	4
Sound power	dB(A)	74	75	75	75	75	77	77	80	80	83	83	85	85
② Sound pressure	dB(A)	46	47	47	47	47	49	49	52	52	55	55	57	57
Electrical supply	V-ph-Hz	220/380-3-50												
DIMENSIONS AND WEIGHTS		46	87	105	139	169	203	238	337	395	477	506	599	639
L - Width	mm	800	1000	1000	1200	1200	1400	1400	1740	1740	2100	2100	2300	2300
H - Height	mm	2110	2595	2595	2800	2800	2860	2860	3140	3140	3380	3380	3450	3450
P - Depth	mm	800	1000	1000	1200	1200	1400	1400	1740	1740	1900	1900	2100	2100
Empty weight	kg	75	85	95	155	170	195	210	380	410	500	525	555	580
Operating weight	kg	180	215	285	470	485	755	780	1380	1410	1800	1825	1955	1980

CEHP MODEL		744	826	878	971	1070	1186	1256	1395	1488	1651	1756	1948	2139	2366	2512	2791
① Nominal heating capacity consumption	kW	744,2	825,6	877,9	970,9	1069,8	1186	1255,8	1395,3	1488,4	1651,2	1755,8	1947,7	2139,5	2366,3	2511,6	2790,7
Installed fan electrical power	kW	4	5,5	5,5	7,5	7,5	11	11	11	2X4	2X5,5	2X5,5	2X7,5	2X7,5	2X11	2X11	2X11
Sound power	dB(A)	90	90	92	92	94	94	95	95	93	93	95	95	97	97	98	98
② Sound pressure	dB(A)	62	62	64	64	66	66	67	67	65	65	67	67	69	69	70	70
Electrical supply	V-ph-Hz	380/660-3-50															
DIMENSIONS AND WEIGHTS		744	826	878	971	1070	1186	1256	1395	1488	1651	1756	1948	2139	2366	2512	2791
L - Width	mm	2025	2025	2365	2365	2875	2875	3370	3370	4080	4080	4750	4750	5770	5770	6770	6770
H - Height	mm	3650	3650	3650	3650	3650	3650	3650	3650	3650	3650	3650	3650	3950	3950	3950	3950
P - Depth	mm	2365	2365	2365	2365	2365	2365	2365	2365	2365	2365	2365	2365	2365	2365	2365	2365
Empty weight	kg	885	920	965	1000	1115	1165	1220	1270	1630	1700	1790	1860	2125	2225	2375	2475
Operating weight	kg	2485	2520	2865	2900	3815	3865	4320	4370	4680	4750	5430	5500	7325	7425	8375	8475

CEHPS MODEL		744	826	878	971	1070	1186	1256	1395	1488	1651	1756	1948	2139	2366	2512	2791
① Nominal heating capacity consumption	kW	744,2	825,6	877,9	970,9	1069,8	1186	1255,8	1395,3	1488,4	1651,2	1755,8	1947,7	2139,5	2366,3	2511,6	2790,7
Installed fan electrical power	kW	5,5	5,5	7,5	7,5	11	11	11	11	2X5,5	2X5,5	2X7,5	2X7,5	2X11	2X11	2X11	2X11
Sound power	dB(A)	79	79	80	80	82	82	83	83	82	82	83	83	85	85	86	86
② Sound pressure	dB(A)	51	51	52	52	54	54	55	55	54	54	55	55	57	57	58	58
Electrical supply	V-ph-Hz	380/660-3-50															
DIMENSIONS AND WEIGHTS		744	826	878	971	1070	1186	1256	1395	1488	1651	1756	1948	2139	2366	2512	2791
L - Width	mm	2025	2025	2365	2365	2875	2875	3370	3370	4080	4080	4750	4750	5770	5770	6770	6770
H - Height	mm	3905	3905	3905	3905	3905	3905	3905	3905	3905	3905	3905	3905	4205	4205	4205	4205
P - Depth	mm	2365	2365	2365	2365	2365	2365	2365	2365	2365	2365	2365	2365	2365	2365	2365	2365
Empty weight	kg	885	920	965	1000	1115	1165	1220	1270	1630	1700	1790	1860	2125	2225	2375	2475
Operating weight	kg	2485	2520	2865	2900	3815	3865	4320	4370	4680	4750	5430	5500	7325	7425	8375	8475

Data at the following conditions:

- ① Air: 24°C W.B. - Water: 35/30° C.
- ② In open field (Q = 2) at 10 m from the unit.

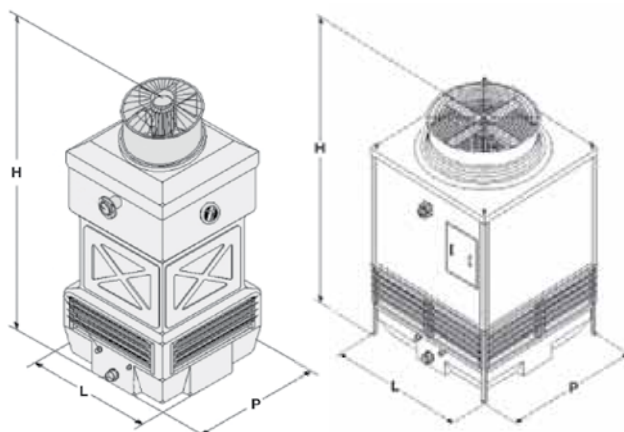

Pumping units

AS 0300÷2500



- Water buffer tank from 300 to 2,500 l
- Multiple combinations for pump user-side
- Connection to the system on the water outlet or return

Pump groups with buffer tank.

Construction features

- Buffer tank: in carbon steel with a capacity of 300, 500, 750, 1,000, 1,500, or 2,500 litres.
- Hydraulic components: single or double centrifugal pump, inlet and outlet shut-off ball valve of each pump, automatic re-integration tap, manual re-integration tap, safety valve, automatic air bleed valve, tank water drain tap, expansion tank with membrane, no-return valve (with double pump only), pressure gauge.
- The water circuit is insulated with closed cell expanded polyurethane of adequate thickness.
- Structure: galvanised and painted sheet steel supporting structure.
- Control: electromechanical

Versions

- AS - Standard version with two connections.

Models

- AS 0300 PU or DPU 1-5: pump unit equipped with single user pump (PU) or double user pump (DPU).
- AS 0500 PU or DPU 1÷5: pump unit equipped with single user pump (PU) or double user pump (DPU).
- AS 0750 PU or DPU 6÷10: pump unit equipped with single user pump (PU) or double user pump (DPU).
- AS 1000 PU or DPU 6÷10: pump unit equipped with single user pump (PU) or double user pump (DPU).
- AS 1500 PU or DPU 6÷14: pump unit equipped with single user pump (PU) or double user pump (DPU).
- AS 2500 PU or DPU 6÷14: pump unit equipped with single user pump (PU) or double user pump (DPU).

Factory fitted accessories

- Buffer antifreeze heater complete with activator.

Separately supplied accessories

- Victaulic connections.

MODEL		AS 0300	AS 0500	AS 0750	AS 1000	AS 1500	AS 2500
Tank capacity	l	300	500	750	1000	1500	2500
Electric pump model		1-2-3-4-5	1-2-3-4-5	6-7-8-9-10	6-7-8-9-10	6-7-8-9-10-11-12-13-14	6-7-8-9-10-11-12-13-14
Expansion tank capacity	l	25	25	25	25	3X25	3X25
Expansion tank pre-load	bar	1,5	1,5	1,5	1,5	1,5	1,5
Safety valve calibration	bar	3	3	3	3	3	3
Maximum working pressure	bar	3	3	3	3	3	3
Electrical resistance (optional)	W	1300	1300	1300	1300	1.300X2	1.300X2
Hydraulic connections (female)	Ø (Gas)	21/2"	21/2"	3"	3"	4"	4"
Minimum liquid temperature	°C	-10	-10	-10	-10	-10	-10
Electrical supply	V-pH-Hz	400-3-50	400-3-50	400-3-50	400-3-50	400-3-50	400-3-50
DIMENSIONS AND WEIGHTS		AS 0300	AS 0500	AS 0750	AS 1000	AS 1500	AS 2500
L - Width	mm	1504	1504	2044	2044	2260	2260
H - Height	mm	1265	1265	1510	1510	1782	1782
P - Depth	mm	1120	1120	1200	1200	1900	1900
Weight (*)	kg	194	215	377	400	660	712
Weight (**)	kg	231	253	501	528	878	930

(*) Empty weight with 1 pump

(**) Empty weight with 2 pumps

TANK	HEAT	Electrical supply	Maximum absorbed power	Flow rate	Useful head	Flow rate	Useful head	Flow rate	Useful head
Capacity (l)	Model	V-pH-Hz	kW	m³/h	m.c.a.	m³/h	m.c.a.	m³/h	m.c.a.
300 or 500	1	400-3-50	1.1	12	15,5	15	13,5	18	11,1
300 or 500	2	400-3-50	1.5	12	19	15	17	18	14,7
300 or 500	3	400-3-50	1.5	21	12,4	24	10,8	30	7,5
300 or 500	4	400-3-50	2.2	21	18,2	24	16,6	30	13,3
300 or 500	5	400-3-50	3	21	20,4	24	18,8	30	15,6
750 or 1,000	6	400-3-50	3	36	18,5	42	16,5	48	14
750 or 1,000	7	400-3-50	5.5	42	27	48	25	60	20
750 or 1,000	8	400-3-50	5.5	60	20	72	17	84	12,5
750 or 1,000	9	400-3-50	7.5	72	22	84	18,5	96	14,5
750 or 1,000	10	400-3-50	11	72	31	84	27,5	96	24
1,500 or 2,500	11	400-3-50	15	72	38,5	84	35	96	31
1,500 or 2,500	12	400-3-50	15	108	29	120	27	138	24,5
1,500 or 2,500	13	400-3-50	18.5	108	34	120	32	138	29,5
1,500 or 2,500	14	400-3-50	22	108	40	120	38,5	138	36

Diagram with AS pump assembly on outlet

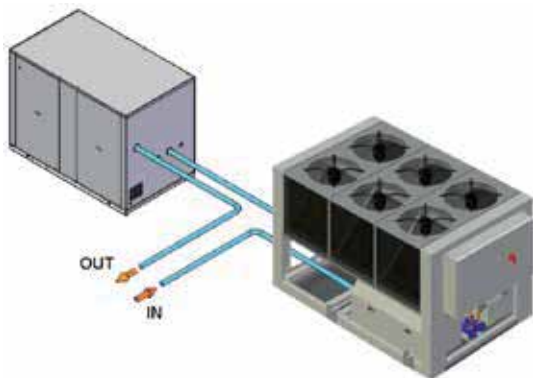
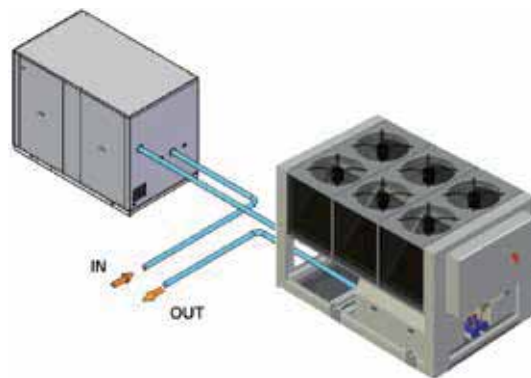

Diagram with AS pump assembly on return



Pumping units

PBHI 0200-0400



- Primary and secondary circuit
- FREECOOLING version
- Electric pump option with integrated inverter

Pump groups with buffer tank.

Construction features

- Buffer tank: in carbon-plated and pre-painted sheet steel, with a 200 or 425 litre capacity.
- Hydraulic components: primary circuit complete with single pump, secondary circuit complete with single standard head pressure pump, storage tank, expansion tank, safety valve, shut-off valves, tank water buffer/drain taps and automatic and manual air bleed valves.
- Heat exchanger: brazed plate exchanger complete with adjustable flow switch (freecooling version only).
- Control: electromechanical.
- Structure: load bearing structure made of galvanised sheet steel and painted with polyester powders. The panels can be removed in order to allow easy access to the internal components.

Versions

- B - Standard version: with single pump for primary and secondary circuit (basic static pressure).
- F - Freecooling version: equipped with indirect freecooling heat exchanger.

Models

- PBHI 0200 B: standard pumping unit.
- PBHI 0400 B: standard pumping unit.
- PBHI 0200 F: freecooling version pumping unit.
- PBHI 0400 F: freecooling version pumping unit.

Factory fitted accessories

- Single secondary circuit electric pump with increased head pressure.
- Double secondary circuit pump with standard or increased head pressure, including one in standby with automatic activation.
- Single centrifugal pump with built-in inverter, able to maintain a constant pressure despite variations in system demands.
- Antifreeze heater 300 W (230V) with activator.

Accessories supplied loose

- Rubber anti-vibration mountings.
- Flexible tubes for connection to the water chiller/heat pump.

PBHI MODEL		0200	0400
Tank capacity	l	200	425
Expansion tank capacity	l	8	12
Expansion tank calibration	kPa	150	150
Safety valve calibration	kPa	600	600
Maximum working pressure	kPa	600	600
Electrical resistance (optional)	W	300	300
Hydraulic connection (female)	Ø (Gas)	2" F	2 1/2" F
Sound power	dB(A)	71	74
Electrical supply	V-ph-Hz	400-3+N-50	400-3+N-50
DIMENSIONS AND WEIGHTS		0200	0400
L - Width	mm	1.340	1.919
H - Height	mm	1.206	1.706
P - Depth	mm	861	863

PBHI water circuit with single pump on user side

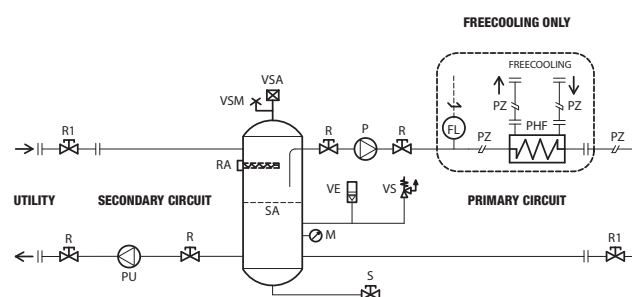

- P - Primary circuit circulation pump.
- PU - Secondary circuit circulation pump.
- DPU - Double secondary circuit circulation pump (factory fitted accessory).
- PUI - Secondary circuit circulation inverter pump (factory fitted accessory).
- FL - Flow switch.
- M - Pressure gauge.
- PZ - Pits with internal diameter 6.2 mm.
- PHF - Plate heat exchanger for FREECOOLING.
- RA - Buffer tank antifreeze heater (factory fitted accessory).
- R - Tap.
- R1 - Tap to be fitted by the installer (provided).
- S - Water drain/charge tap (outside the buffer tank).
- SA - Buffer tank.
- VE - Expansion tank calculated to contain the water from the buffer tank only (-10°C - +60°C).
- VR - Non-return valve.
- VS - Safety valve.
- VSA - Automatic air bleed valve.
- VSM - Manual air bleed valve.
- || - Fittings.

SECONDARY CIRCUIT PUMP ACCESSORIES:

PBHI water circuit with double pump on user side

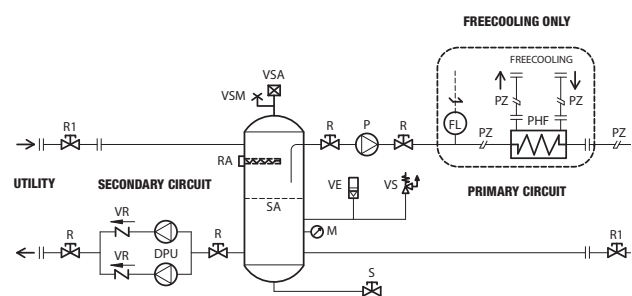

PUMP WITH INVERTER

Regulation at constant pressure

PBHI water circuit with single inverter pump on user side

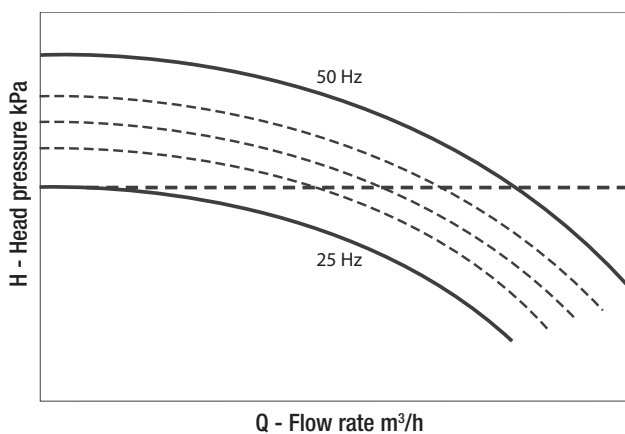
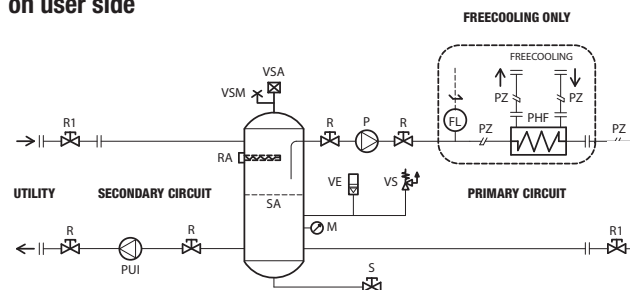

Integrated system management - ADJUSTMENT FOR HEAT PUMP SYSTEMS

Integrated system management - RHOSS TOUCH MANAGER

Integrated system management - iDRHOSS

Remote monitoring - RHOSS MONITORING: Mobile - Cloud - Real time

Control and monitoring via ETHERNET - RHOSS WEB SERVER

System supervision - RHOSS SUPERVISOR

Water Chiller management software - SIR - RHOSS INTEGRATED SEQUENCER

Water Chiller management software - RHOSS SEQUENCER



**SOLUTIONS TO CONTROL THE INTEGRATED SYSTEM,
MONITOR AND SUPERVISE**

Integrated system management

ADJUSTMENT FOR HEAT PUMP SYSTEMS



RHOSS SOLUTIONS FOR RESIDENTIAL AND SMALL SERVICE INDUSTRY APPLICATIONS

Rhoss offers a wide range of installation solutions and comprehensive systems for heating, cooling and domestic hot water production.

From the simplest solution where the heat pump autonomously meets the house's heating demand, to the most advanced solutions equipped with intelligent regulation for centralised management of the entire system and to meet heating, cooling, dehumidification and domestic hot water production needs all year round.

All that with a view to addressing in the most adequate manner the various system engineering needs, either in new or existing buildings, optimising efficiency and ease of installation.





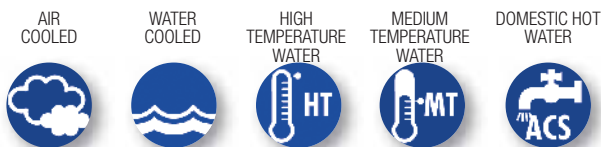



















Suggested solutions:

- Heating with radiators.
- Heating/cooling with fan coil units.
- Heating with radiators and/or fan coil units and DHW production.
Possibility to cool with fan coil units.
- Heating with fan coil units and/or radiant panels and DHW production.
Possibility to cool with fan coil units.
- Heating/cooling with fan coil units and/or radiant panels and DHW production.
- Heating with heat pump or boiler.



COMPATIBLE PRODUCTS

Heat pumps

-   **ELECTA** - THAITY 105÷116 
-   **Low consumption Mini-Y NF** - THAEY 105÷111 NF
-   **Low consumption Compact-I** - THAITY 117÷128 
-   **Low consumption Compact-Y NF Plus** - THAEY 115÷127 NF
-   **Low consumption compact-I MD** - THAITY 236÷260 
-   **Low consumption POKER** - THAEY 234 H.T.
-   **Low Consumption Comby-Flow** - THHEY 105÷112
-   **Low consumption Y-Flow** - THHEY 115÷240
-    **Compact-Y EXP SM** - TXAEY 117÷130
-    **Low consumption Comby-Flow EXP** - TXHEY 105÷112

Fan coils

- Fan coils with brushless motor** - YARDY-I EV3 
- Fan coils** - YARDY EV3
- Ductable fan coils with brushless motor** - YARDY-ID2 
- Ductable fan coils** - YARDY-DUCT2
- Ductable terminals** - YARDY-HP
- Fan coils with brushless motor** - DIVA-I 
- Fan coils** - DIVA

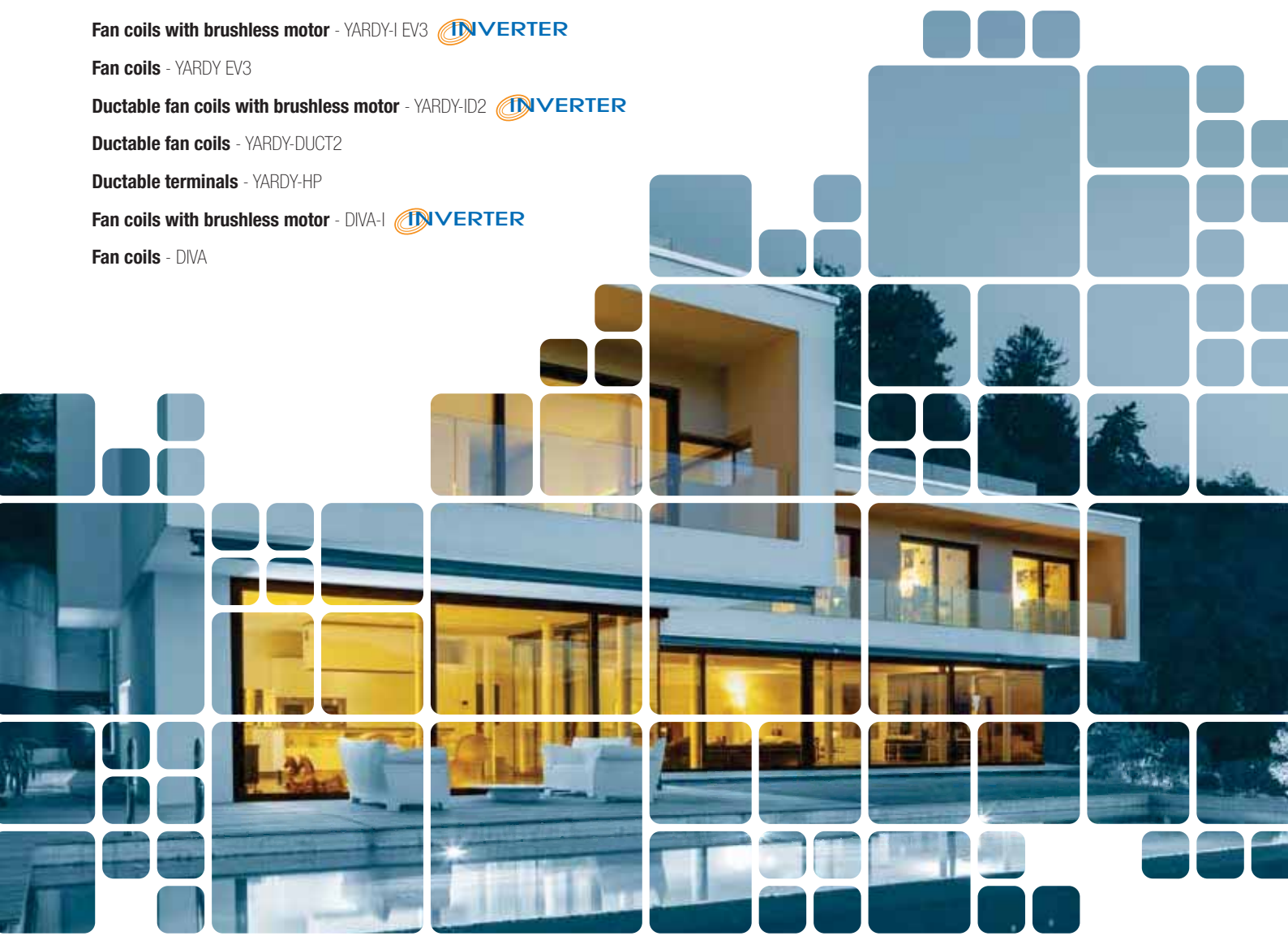

Integrated system management

ADJUSTMENT FOR HEAT PUMP SYSTEMS

KTTZ - Temperature user terminal



KTTUZ - Temperature/humidity user terminal



KCSI - System control unit



KCSIE - Expansion control unit



KRS485 - RS485 Serial interface board



KTR - Remote keyboard



KEAP - Temperature probe



KEAP - Wall temperature probe



KFA - Water filter



KRIT - Piping electrical heater



KVDEV - Diverter valve for DHW



KVS - Solenoid valve

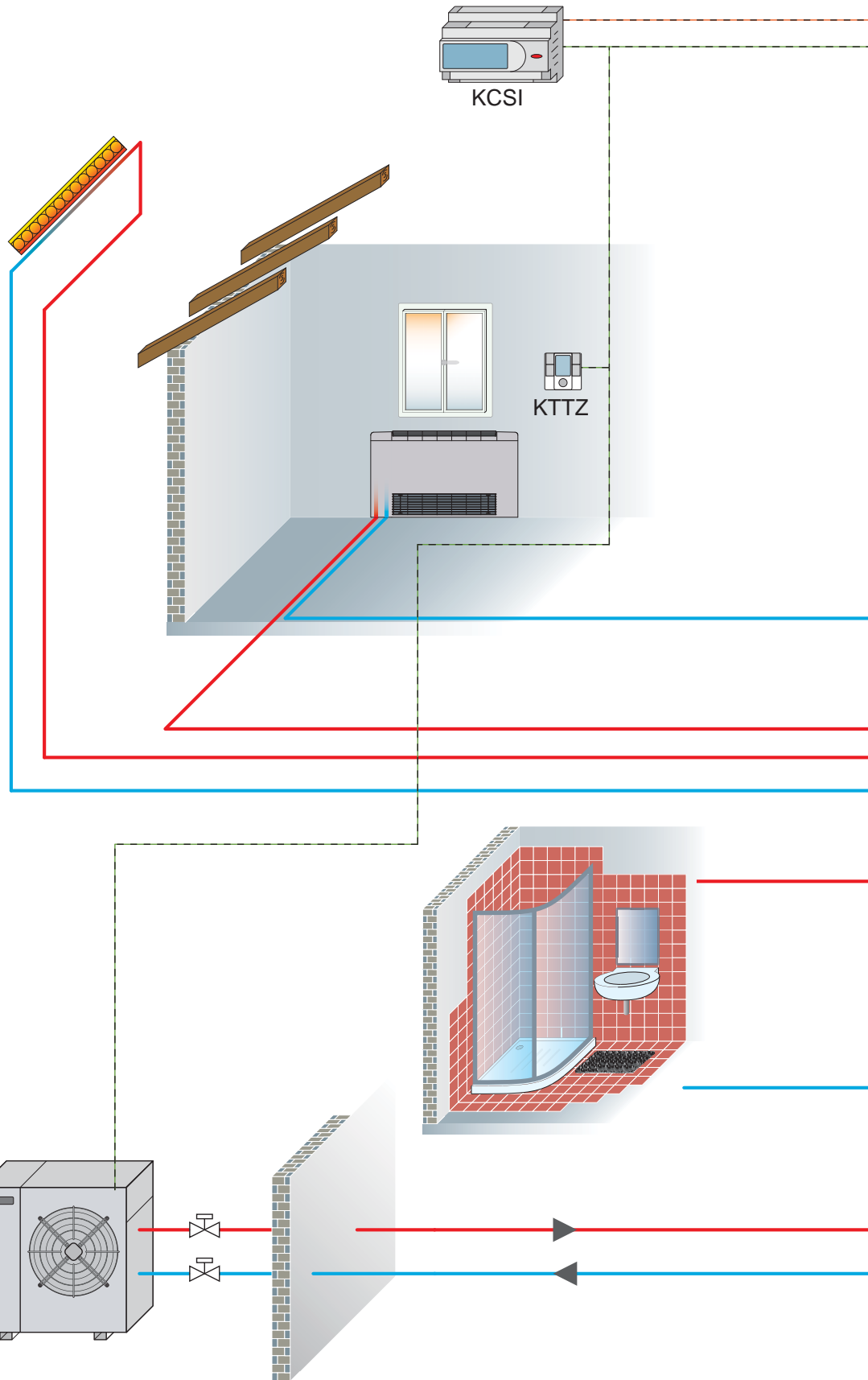

EXAMPLE OF HEATING/COOLING SOLUTION WITH FAN COIL UNITS AND/OR RADIANT PANELS AND DHW PRODUCTION

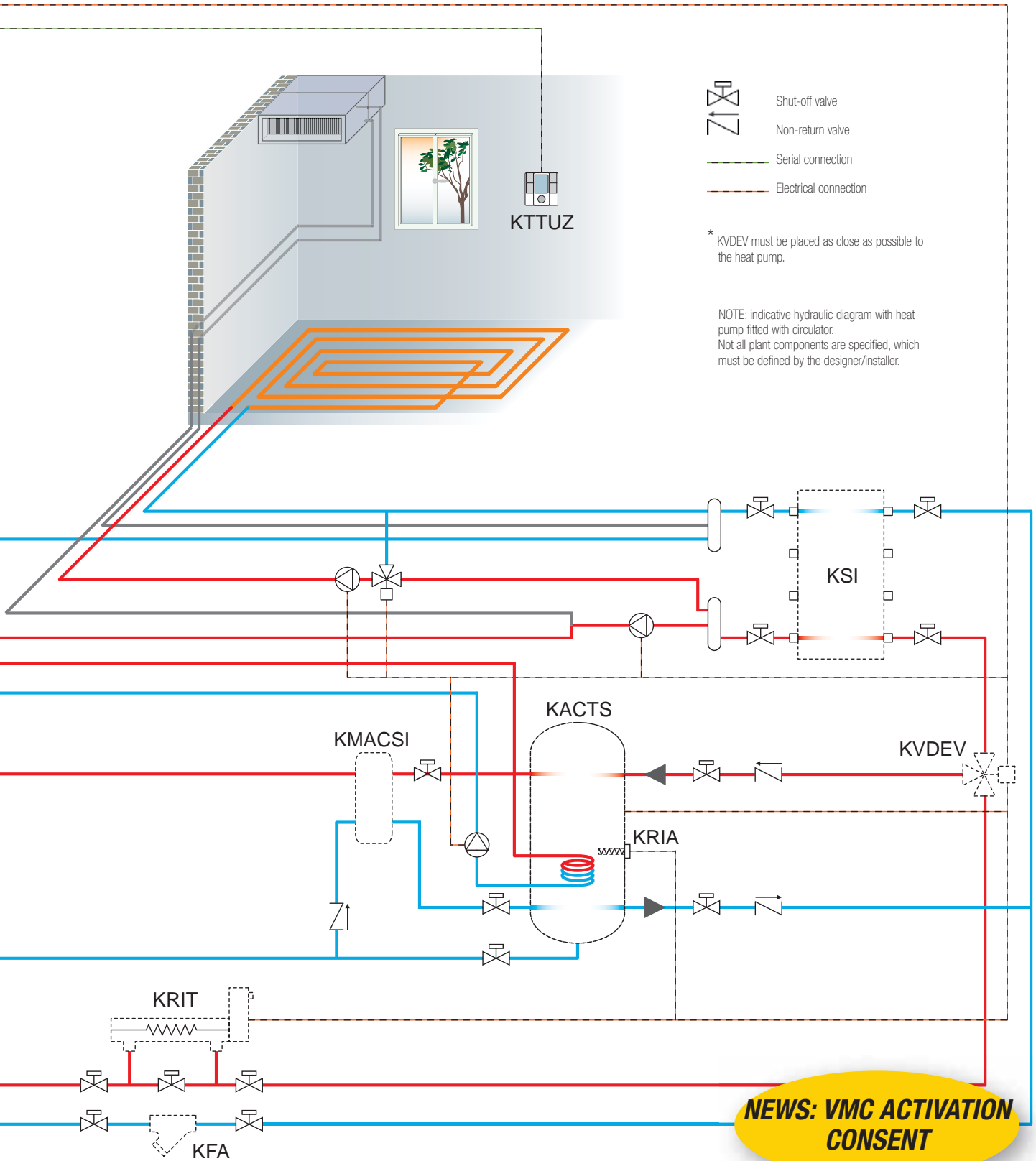

KSI - Hydraulic separator



KACT/KACTS - Technical water tank

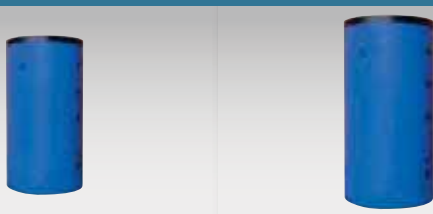

KRIA - Tank electrical heater



KMACSI - DHW Module



Integrated system management

RHOSS TOUCH MANAGER

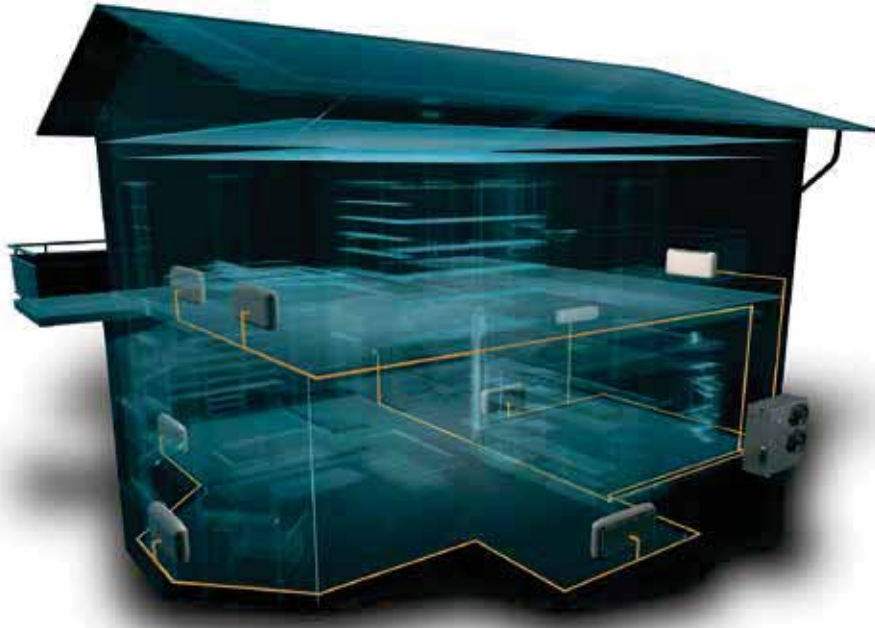

- **Solution for the small and medium sized service sector**
- **Easy and intuitive control of every area of the building in a customised manner based on the occupants' needs**
- **Connection via RS485 network or Ethernet**
- **Rhoss units that may be connected**
 - **Option 1: network of chiller units only**
From 1 to 5 chiller units
 - **Option 2: network of fan coils only**
From 1 to 64 fan coils
 - **Option 3: network with fan coils and chiller unit**
1 chiller unit and from 1 to 64 fan coils
- **Pages with synoptic diagrams of the main components, graphs, option to modify main parameters, alarm display.**
- **Connectible to LAN Ethernet, compatibility with Internet Explorer via plug-in**

TOUCH MANAGER



Control panel for centralised management of all the units in the system.



Controls for fan coils



Flush panel



Recessed panel



Wall mounted receiver

Remote control

Cooling unit



NETWORKED SOLUTION RS485 (MODBUS RTU PROTOCOL)



TOUCH MANAGER FUNCTIONS

MAIN FUNCTIONS

- Switching the entire plan on and off (cooling unit and terminals)
- Display of the status and the operating mode in real time
- Centralised management of various zones and modification of the main functional parameters (set-point, operating mode, fan speed)
- Two levels of preset comfort/economy settings which can be set centrally

DAILY AND WEEKLY TIME BANDS FOR GENERATORS AND ZONES

- Daily time bands
- Time band control differentiated for the various days of the week

SEASONAL SWITCH

Managing by date

ALARMS STATE

Display any alarm conditions

BOILER CONSENT

Manual or by date by means of digital contacts (special option on request)

RECOVERY UNIT CONSENT

Manual or by date by means of digital contacts (special option on request)

SYSTEM PUMP CONSENT

Manual or by date by means of digital contacts (special option on request)

USER INTERFACE

- Resistive touch screen with user friendly graphical interface
- Display dimensions: 7.0"

TERMINAL ROUTING in RS485 network

Via panel KPCM

MANAGEABLE FAN COILS

IDROWALL-I	YARDY-I EV3 / YARDY EV3	YARDY-ID2/YARDY-DUCT2	YARDY-HP	DIVA-I / DIVA
	KTVDM - KTVDIM	KTVDM - KTVDIM	KTVDM	KTVDM - KTVDIM

IDRHOSS
Controls

STANDARD
Controls

Integrated system management



HYDRONIC COMFORT SOLUTIONS



- Solution for the small-sized service industry.
- iDRHOSS is a management system of hydronic air conditioning systems, developed to meet the comfort needs of any civil location.
- iDRHOSS offers a series of functions, such as centralised management, automatic summer-winter switch and operating time bands, whilst always working towards energy saving.



Controls for fan coils



Flush panel



Recessed panel



Wall mounted receiver



Remote control

Area terminal

The control panel for centralised management of all the units in the system.



SOLUTION IN CAN-BUS NETWORK



Cooling unit





AREA TERMINAL AND iDRHOSS SYSTEM FUNCTIONS

MAIN FUNCTIONS

- Switching the entire plan on and off (cooling unit and terminals)
- Display of the status and the operating mode in real time
- Centralised management of various zones and modification of the main functional parameters (set-point, operating mode, fan speed, sleep/economy mode)

DAILY AND WEEKLY TIME BANDS FOR GENERATORS AND ZONES

- Two switch-on time bands that can be set during the day
- Time band control differentiated for the various days of the week

SEASONAL SWITCH

- Managing by date or automatically according to the status of the terminals

ALARMS STATE

Display any alarm conditions

COOLING UNIT MANAGEMENT

Activation, summer/winter switch and generic alarm signal

BOILER MANAGEMENT

- Manual or by date

USER INTERFACE

Semi-graphical backlit display and 6-key keyboard
Dimensions 156x82x30 mm

TERMINAL ROUTING in CanBUS network

By means of the KPCM panel or dip switches present on the serial Can bus board

MANAGEABLE FAN COILS

YARDY-I EV3 / YARDY EV3	YARDY-ID2/YARDY-DUCT2	YARDY-HP	DIVA-I / DIVA

Remote monitoring

RHOSS MONITORING: Mobile - Cloud - Real time

- Remote management of cooling units, handling units and small residential systems with PDC system (*)
- 3 different solutions for remote monitoring with GSM-GPRS network
- Connection via mobile or smartphone
- Web interface with Cloud service
- Status display in real time
- Data logger function
- Alarm and malfunctioning alerts
- Installation of the device on DIN bar, within the unit's electrical panel



**RHOSS COOLING UNIT +
SERIAL INTERFACE**



MONITORING	MAIN FEATURES	CONTROL DEVICE	INTERNET CLOUD SERVICE	SIM CARD
MOBILE for residential and small-size service sector applications	Input/output management via mobile phone and editing by SMS . Alarm and malfunctioning alerts. Reading up to 8 values.		Not provided (only SMS management available)	
CLOUD for residential and service sector	Management of the main parameters and editing via internet interface or via APPS IOS and ANDROID. Alarm, malfunctioning display with hourly frequency and trend logs. Reading up to 8 values.	KMMC - Remote Mobile/Cloud control device with slot for SIM CARD	Internet Cloud service by subscription (minimum length 1 year)	Responsibility of the user or by subscription (not required if local Internet connection is used)
REAL TIME for the service and industrial sector	Management of the parameters and editing via internet interface or via APPS IOS and ANDROID. Real time alarm, malfunctioning display and trend logs. Reading up to 100 values.	KMRT - Real Time control device with slot for SIM CARD	Obligatory	

(*) to be verified at the offer stage and configuration for CTA and PDC system



CONTROL DEVICE + SIM card



CONTROL DEVICE	Serial interface on Rhoss unit	Remotely manageable inputs/outputs	Monitorable Rhoss units	Readings
 <p>KMRC - Remote control device for Rhoss Monitoring Mobile or Cloud, installation on DIN bar (4 modules) within the unit's electric panel, slot for SIM CARD, status and inputs/outputs signalling LED, antenna with 3m cable, protection degree IP40, GSM dual band module 900-1800 MHz, Buffer battery (1 hour approximately); serial ports; Power supply 15÷40V dc or 11÷28V ac 50Hz.</p>	RS485 Serial interface (accessory KRS485 or SS)	<ul style="list-style-type: none"> • 2 relay outputs configurable and activated via SMS • 2 digital inputs for external alarms • 1 configurable analogue input (0-10 V, 0-20 mA, 4-20 mA) 	1	<ul style="list-style-type: none"> • cooling unit • air handling units • PDC system (KCSI) <p>up to 8 readings</p>
 <p>KMRT - Remote control device Rhoss Monitoring Real Time, installation on DIN bar (6 modules) within the unit's electric panel, slot for SIM CARD, 3 status signalling LEDs, antenna with 3m cable, protection degree IP40, GSM/GPRS Modem, serial ports; Watchdog hardware, Real Time Clock; Power supply 9-36Vdc (12-24Vac +/-10%). NOTE: the KMRT device is fitted with additional Ethernet interface for using local Internet connection (without SIM CARD).</p>	<ul style="list-style-type: none"> • RS485 serial interface (accessory KRS485 or SS) • Ethernet Interface (accessory KBE) [only if Ethernet is available on site] 	Not available	5	<ul style="list-style-type: none"> • cooling unit • air handling unit • PDC system (KCSI) <p>up to 100 readings</p>

Control and monitoring via ETHERNET

RHOSS WEB SERVER

- **Managing a single cooling unit via ETHERNET**
- **Web page with unit status and detailed tabs with:**
 - synoptic of the main components
 - graphic trend of the main variables
 - possibility of modifying the main parameters (on/off, mode, setting)
 - status and alarms reset
- **Installation of the ethernet interface inside the unit's electrical panel**



WEB SERVER MAIN FEATURES	MAIN COMPONENTS	ADDITIONAL COMPONENTS
<p>Web page with unit status and detailed tabs displaying:</p> <ul style="list-style-type: none"> - synoptic diagram of the main components - main variable trend graph - option to edit main parameters (on/off, mode, set) - alarm status and reset 	<ol style="list-style-type: none"> 1) Web Server board for Ethernet 2) User graphical interface 	<p>KCSI - System control unit to be provided only for range:</p> <ul style="list-style-type: none"> - ELECTA - T-POWER

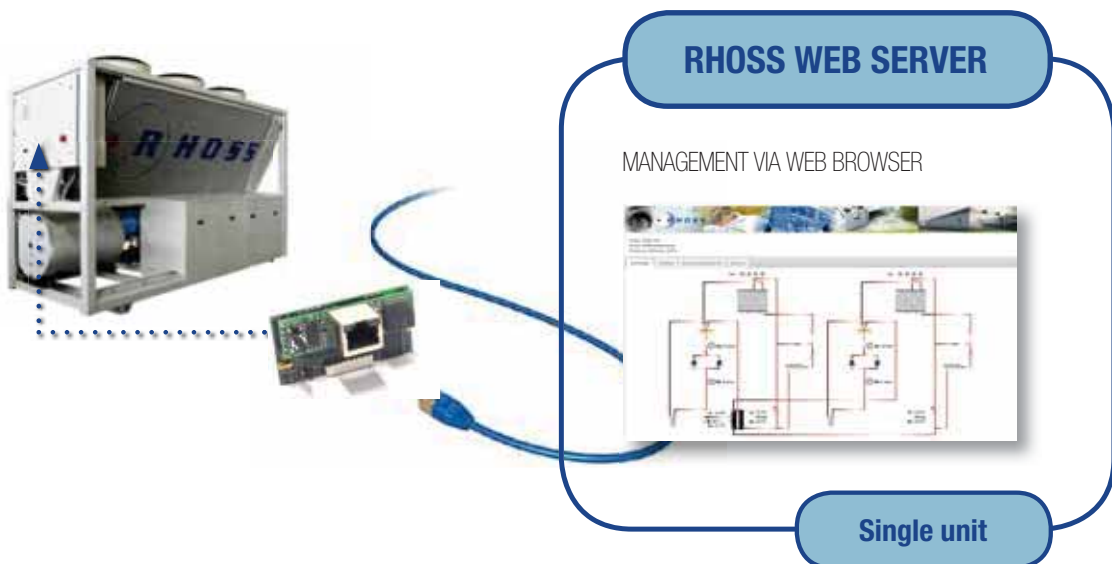

RHOSS COOLING UNIT + Web Server for Ethernet + User graphical interface

System supervision

RHOSS SUPERVISOR

- **Solution for the medium and large-sized service industry**
- **“All in one” supervisor & “Touch screen”**
- **Display and local control (built-in touch-screen monitor)**
- **Connection through local network (Internet Explorer)**
- **Option of remote connection via Internet**
- **Direct connection to units/network with no additional components**



- The new RHOSS Supervisor is a global, simple and complete solution for plant monitoring and management.
- The product offers an interface with built-in touch-screen monitor and includes all field and remote connections to Rhoss system devices, connected through an RS485 network.
- It allows for the operation of RHOSS chillers, heat pumps, multi-purpose units, fan coils and terminal units to be supervised, via an easy to use Microsoft Internet Explorer interface.
- The new Supervisor makes direct control possible thanks to the built-in monitor and it can also be viewed from other connected devices in a local network (Ethernet LAN) or to remote users, who just need a simple Internet connection (the network must be suitably configured by the user to enable remote access).
- Supported languages Italian, English, German.
- The Rhoss unit connected over the network to the Supervisor must be fitted with an RS485 board.
- On demand it is possible to supply an overview diagram with customised graphics Interface and connection to other non RHOSS devices or other supervisors in the RS485 Modbus RTU network.

The new Supervisor offers the following features:

- ✓ Data display of devices in the field (temperature, pressure, I/O status) and display/setting configuration parameters (set point, etc.) for each individual machine connected.
- ✓ System interface, data recording, reporting with trends and graphs of all variables recorded in the installation, report generation in PDF/Excel with the option of sending periodic e-mails and scheduling activities.
- ✓ Centralised device configuration (e.g. ON/OFF, operation mode change, setting temperature and speed for fan coils).
- ✓ Maintenance with remote access.
- ✓ Alarm management with warnings and automatic tripping in local display, via relay or by sending e-mail, fax, SMS (with GSM modem not supplied by RHOSS).
- ✓ 7-day time programming of connected devices with the ability to configure groups of devices common to the same area (e.g. by floor).

Rhoss supervisor is available in two configurations:

- KRSE90 - RHOSS SUPERVISION (90 DEVICES)
- KRSE300 - RHOSS SUPERVISION (300 DEVICES)

MANAGEABLE FAN COILS

YARDY-I EV3 / YARDY EV3	YARDY-ID2/YARDY-DUCT2	YARDY-HP	DIVA-I / DIVA
KTVDM - KTVDIM	KTVDM - KTVDIM	KTVDM	KTVDM - KTVDIM

Chiller management software

SIR - RHOSS INTEGRATED SEQUENCER

new

- **MASTER/SLAVE management of up to 4 parallel plumbing chillers**
- **Summer/winter mode for heat pump units**
- **System set-point management**
- **Control of all operating parameters**



- The SIR integrated Sequencer makes it possible to manage up to 4 parallel plumbing chillers in medium/large HVAC systems.
- The optimisation of operating times and the insertion of the individual units is controlled by logics integrated in their management software, guaranteeing reliability over time.
- The software at the heart of the system was designed and tested by the Rhoss R&D structure and is able to acquire and manage the main variables of the connected water chillers.
- Depending on the product range, the units of the group can interface with the main BMS on the market, for them to be monitored, to guarantee full control of each type of system (verify the option in the product documentation).

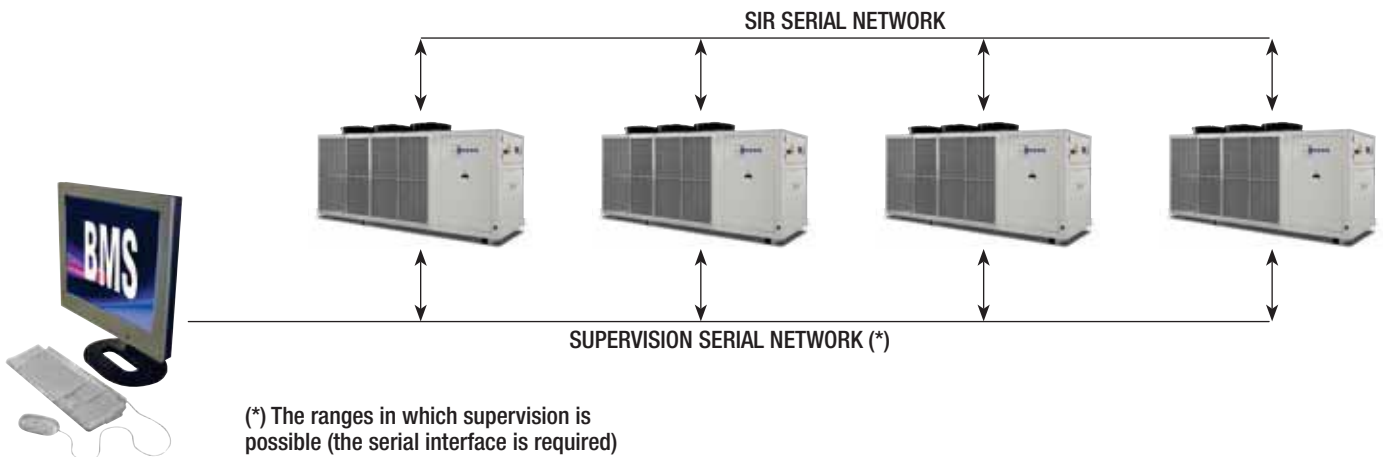

- WinPOWER
- Z-Power
- Z-Power HP
- Z-Flow HE
- Z-Flow
- Z-Flow E

Water Chiller management software

RHOSS SEQUENCER

- **Control of up to 10 parallel plumbing chillers**
- **Summer/winter mode for heat pump units**
- **System set-point management**
- **Control of all operating parameters**
- **Alarm display**



- The Rhoss Multichiller Sequencer makes it possible to manage up to 10 parallel plumbing chillers in medium/ large HVAC systems.
- The optimisation of operating times and the insertion of the individual units is controlled by logics that focus on energy efficiency, guaranteeing reliability over time.
- The management mode of the units can be selected from between FL-Full Load Unit Manager (specific for screw compressor chillers) and PL-Part Load Unit Manager (specific for water chillers with scroll compressors).

- A dedicated sequencer is available for EXP multi-purpose units that can handle all the specific functions of the technology.
- The software at the heart of the system was designed and tested by the Rhoss R&D structure and is able to acquire and manage the main variables of the connected water chillers. The sequencer also interfaces with the main BMS available on the market, guaranteeing complete control in all system types. Integrated solutions for system management

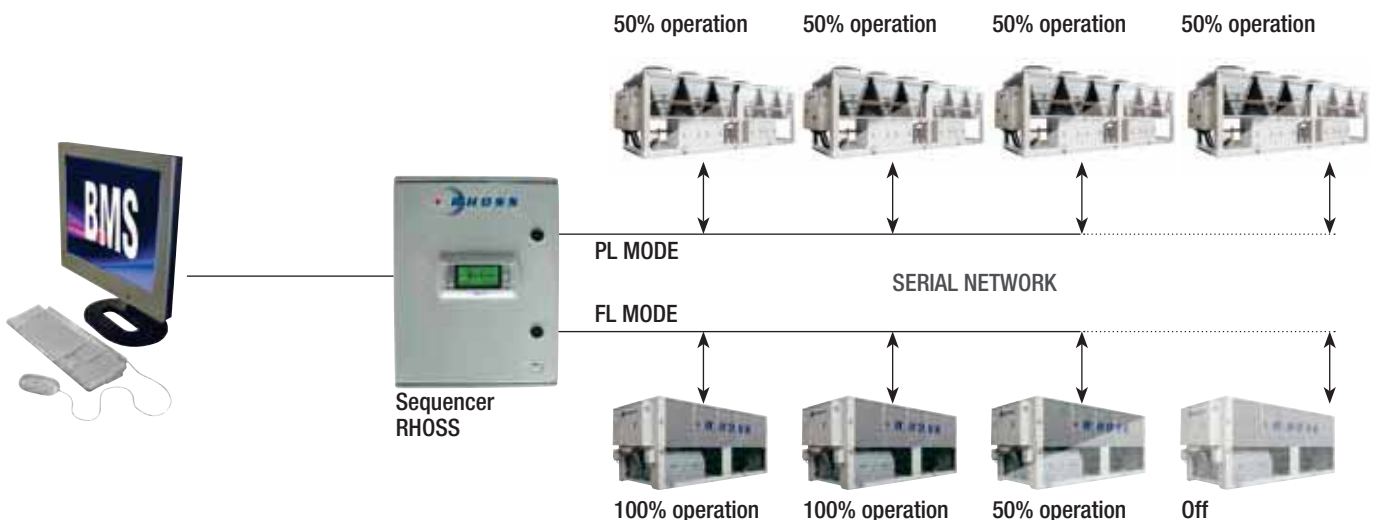



FAN COILS

Fan coils with brushless motor

IDROWALL-I

Cooling capacity: 2.0÷3.5 kW - Heating capacity: 3.0÷5.1 kW

INVERTER



- Consumption reduced by 50% compared to the traditional motor
- On board 3-way valve
- Integrated serial interface and master/slave function

Wall mounted fan coils.

Construction features

- Heat exchanger: finned coil.
- Fan: tangential with Inverter Brushless EC motor with continuous speed adjustment.
- Deflector: motorised with different positions.
- Structure: made of heat-resistant ABS polymer, RAL 9003 colour, complete with renewable polypropylene filter, direction-adjustable fins and condensation drain pan with natural drainage.
- Unit equipped with a 3-way ON/OFF valve and resident RS485 serial interface.
- Control: microprocessor electronic control.
Regulation functions: full auto, cool, dry, fan, autofan, heat. Comfort functions: orienting, swing, timer, sleep, hot start, memory.
Remote control supplied as standard.

Separately supplied accessories

- KV2V - 2-way ON/OFF valve accessory.
The installer is responsible for on board assembly.
- K2TF - Accessory for electrovalve use out of the unit. Assembled by the installer.
- KVAM - Wall mounted recessed box.

Controls supplied loose

- KWPI - Electronic panel for wall mounting.
- KWPCI - Centralised electronic panel for wall mounting Power supply V230-1-50.
- KGTW-BAC- Gateway RS485/BACnet (max 64 fan coil).
- KGW-LON - Gateway RS485/FTT10-LonWorks (max 64 fan coil).



KWPCI centralised panel

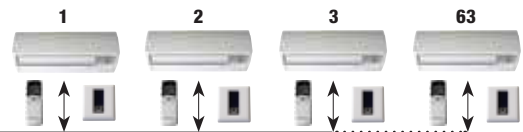

CENTRALISED MANAGEMENT OF UP TO 63 UNITS DISTANCE UP TO 1200 m

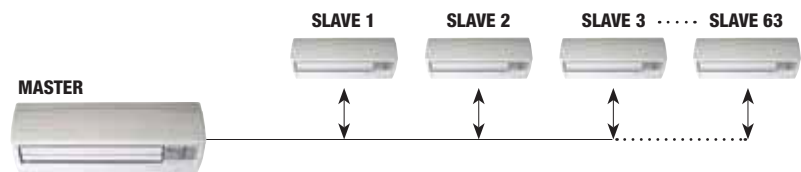

MASTER/SLAVE MANAGEMENT OF UP TO 64 UNITS FOR A TOTAL DISTANCE OF 1200 m



Remote control

Flush panel KWPI



IDROWALL-I			21	31	41
❶ Total cooling capacity	MAX	kW	2,01	2,98	3,54
	MED	kW	1,64	2,15	2,47
	MIN	kW	1,33	1,9	1,9
❷ Total cooling capacity [EN1397]	MAX	kW E	1,99	2,95	3,5
	MED	kW E	1,63	2,14	2,45
	MIN	kW E	1,32	1,89	1,89
❸ Heating capacity (45°C) [EN1397]	MAX	kW E	2,68	4,21	4,45
	MED	kW E	2,02	3,05	3,64
	MIN	kW E	1,45	2,61	2,61
❹ Heating capacity (50°C)	MAX	kW	3,05	4,78	5,14
	MED	kW	2,34	3,46	4,11
	MIN	kW	1,72	2,98	2,98
❺ Heating capacity (70°C) [EN1397]	MAX	kW	5,53	8,49	9
	MED	kW	4,2	6,23	7,38
	MIN	kW	3,02	5,36	5,36
Air flow speed	MAX	m³/h	556	722	814
	MED	m³/h	413	473	581
	MIN	m³/h	295	396	396
❻ Sound power	MAX	dB(A) E	52	55	59
	MED	dB(A) E	43	46	51
	MIN	dB(A) E	34	42	42
Sound pressure	MAX	dB(A)	43	46	50
	MED	dB(A)	34	37	42
	MIN	dB(A)	25	33	33
Absorbed power	MAX	W E	22	27	38
	MED	W E	14	15	19
	MIN	W E	11	12	12
Electrical supply	V-ph-Hz	230-1-50	230-1-50	230-1-50	
DIMENSIONS AND WEIGHTS			21	31	41
L - Width	mm	795	990	990	
H - Height	mm	290	290	290	
P - Depth	mm	230	230	230	
Weight	kg	9,3	11,6	11,6	

Data at the following conditions:

- ❶ Air: 27°C D.B.; 19°C W.B. - Acqua: 7/12°C.
- ❷ Air: 20°C - Water: 45/40°C.
- ❸ Air: 20°C - Water: 50°C, flow rate as in cooling.
- ❹ Air: 20°C - Water: 70/60°C.
- ❺ For room volume equal to 100 m³ and reverberation time = 0.5 sec.

E Eurovent certificated performances.



Remote control
 ●
 Centralized panel
 ●
 Flush panel

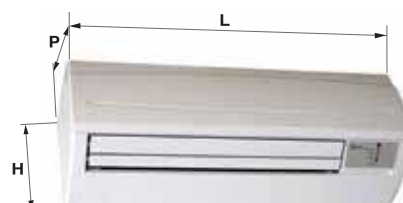



- Enhanced performance with 4 row coils
- 50% lower consumption with respect to traditional motor
- Continuous fan speed variation
- Quieter operation
- Better room comfort

Fan coils with brushless motor

YARDY-I EV3

Cooling capacity: 1.9÷8.6 kW - Heating capacity: 2.5÷11.8 kW



INVERTER



Floor, or ceiling, recessed wall or false ceiling installation fan coils with cabinet.

Construction features

- Heat exchanger: finned coil with left-hand connections reversible to right.
- Centrifugal fan with an inverter controlled brushless electronic motor and continuous speed adjustment.
- Cover cabinet version structure: covering cabinet in pre-painted sheet metal complete with renewable filter, ABS polymer grilles and condensation drain pan with natural drainage.
- Recessed version structure: in galvanised sheet steel, complete with condensation drain pan with natural drainage and renewable filter.

Versions

- MVP - Vertical unit with cabinet equipped with lower air inlet and upper outlet for wall mounting or with feet on ground.
- MVT - Vertical unit with cabinet equipped with front air inlet and upper outlet for floor installation.
- MXP - Horizontal/vertical unit with cabinet, equipped with lower air inlet and upper outlet, for ceiling installation, wall-mounting or with feet on ground.
- MXT - Horizontal/vertical unit with cabinet, equipped with front air inlet and upper outlet, for ceiling or floor installation.
- IVP - Recessed vertical unit equipped with lower air inlet and upper outlet for wall installation.
- IVF - Recessed vertical unit equipped with lower air inlet and front outlet for wall installation.
- IXP - Horizontal/vertical unit equipped with lower air inlet and upper outlet for false ceiling or recessed wall installation.

Accessories

- Additional water heating coil.
- Electrical heater.
- ON/OFF 2-way valves for 2 and 4-pipe-systems.
- ON/OFF 3-way valves for 2 and 4-pipe-systems.
- Auxiliary condensation drain pan.
- Manual damper.
- Motorised damper.
- Rear panel.
- Rear closure panel.
- Rear closure panel with grille and filter.

- Support feet with pipe cover.
- Frame with filter (G2) that can be extracted in any direction.
- Outlet straight connection.
- 90° outlet and inlet connection.
- Telescopic outlet/inlet connection.
- Inlet grille with filter.
- Outlet grille.
- Cover panel with grilles (only IXP).
- Flange for connection to duct.
- Antivibration connection for connection to the inlet or outlet duct.
- Inlet/outlet plenum with circular nozzles.

STANDARD Controls

For wall mounting installation

- Electronic panel with display and RS485 serial interface, semi-recessed in wall.

iDRHOSS Controls

- Wall mounting receiver for distance remote control.
- Electronic panel for wall mounting or on board installation.
- Wall-mounted recessed electronic panel



For installation on machine.

- Master/slave electronic board, ON/OFF valve control module and electrical resistance, temperature probe for hot row.
- RS485 interface for serial communication with other devices (proprietary protocol; Modbus RTU protocol).
- RS 485/USB serial converter.
- Serial interface (CAN-bus - Controller Area Network) for the iDRHOSS system.
- KGTW-BAC- Gateway RS485/BACnet (max 64 fan coil).
- KGW-LON - Gateway RS485/FTT10-LonWorks (max 64 fan coil).

- Key: ♦ Factory fitted
 → Supplied separately





YARDY-I EV3 MVP-MVT-MXP-MXT-IVP-IVF-IXP			20	24	30	34	45	48	60	74	80	88
❶ Total cooling capacity	MAX	kW	1,88	2,25	3	3,4	4,15	4,64	6,37	7,41	8,08	8,55
	MED	kW	1,45	1,69	2,33	2,77	3,06	3,49	4,62	5,27	5,92	6,38
	MIN	kW	0,75	0,81	1,09	1,35	1,54	1,74	1,79	2,11	2,11	2,26
❶ Total cooling capacity [EN1397]	MAX	kW E	1,86	2,23	2,97	3,37	4,11	4,6	6,28	7,32	7,94	8,4
	MED	kW E	1,44	1,68	2,32	2,75	3,05	3,48	4,59	5,24	5,87	6,32
	MIN	kW E	0,74	0,8	1,08	1,34	1,53	1,73	1,78	2,1	2,1	2,25
❷ Heating capacity (45°C) [EN1397]	MAX	kW E	2,09	2,18	3,27	3,41	4,46	4,65	7,13	7,41	9,67	10,07
	MED	kW E	1,48	1,56	2,52	2,6	3,13	3,27	5,13	5,31	7,15	7,43
	MIN	kW E	0,77	0,81	1,2	1,23	1,51	1,57	1,88	1,94	2,63	2,74
❸ Heating capacity (50°C)	MAX	kW	2,47	2,59	3,87	4,06	5,28	5,54	8,38	8,8	11,29	11,77
	MED	kW	1,77	1,88	2,99	3,14	3,74	3,93	6,07	6,37	8,39	8,75
	MIN	kW	0,91	0,96	1,42	1,49	1,81	1,9	2,24	2,35	3,07	3,22
❹ Heating capacity (70°C) [EN1397]	MAX	kW	4,2	4,35	6,56	6,83	8,92	9,31	14,28	14,85	19,36	20,15
	MED	kW	2,98	3,14	5,06	5,26	6,28	6,56	10,3	10,77	14,35	14,91
	MIN	kW	1,55	1,62	2,44	2,51	3,06	3,19	3,85	3,96	5,37	5,6
❺ Heating capacity of additional coil (65°C) [EN1397]	MAX	kW E	1,95	2,07	2,94	2,8	3,37	3,2	5,63	5,37	6,51	6,16
	MED	kW E	1,66	1,57	2,34	2,23	2,84	2,71	4,68	4,45	5,4	5,14
	MIN	kW E	0,88	0,83	1,29	1,23	1,54	1,46	2,17	2,06	2,52	2,4
❹ Heating capacity of additional coil (70°C)	MAX	kW	2,19	2,33	3,3	3,14	3,79	3,6	6,29	5,98	7,23	6,83
	MED	kW	1,91	1,81	2,63	2,5	3,29	3,13	5,27	5,01	6,07	5,77
	MIN	kW	1	0,95	1,47	1,4	1,78	1,69	2,49	2,37	2,89	2,75
Air flow speed	MAX	m³/h	331	331	523	523	645	645	1235	1235	1503	1458
	MED	m³/h	230	230	400	400	450	450	780	780	965	965
	MIN	m³/h	97	97	167	167	198	198	256	256	300	300
Sound power	MAX	dB(A) E	48	48	50	50	51	51	62	62	66	66
	MED	dB(A) E	40	40	43	43	42	42	50	50	56	56
	MIN	dB(A) E	23	23	24	24	25	25	27	27	32	32
❻ Sound pressure	MAX	dB(A)	39	39	41	41	42	42	53	53	57	57
	MED	dB(A)	31	31	34	34	33	33	41	41	47	47
	MIN	dB(A)	14	14	15	15	16	16	18	18	23	23
Absorbed power	MAX	W E	23	25	26	28	39	42	89	95	136	146
	MED	W E	13	14	15	16	14	15	28	30	52	56
	MIN	W E	6	6	6	6	7	8	7	7	9	10
Electrical supply	V-ph-Hz	230-1-50	230-1-50	230-1-50	230-1-50	230-1-50	230-1-50	230-1-50	230-1-50	230-1-50	230-1-50	230-1-50
DIMENSIONS AND WEIGHTS			20	24	30	34	45	48	60	74	80	88
L - MXP-MXT-MVP-MVT width	mm	800	800	1000	1000	1200	1200	1500	1500	1500	1500	1500
L - IVP-IXP-IVF width	mm	550	550	750	750	950	950	1250	1250	1250	1250	1250
H - MXP-MXT-MVP-MVT height	mm	570	570	570	570	570	570	570	570	570	570	570
H - IVP-IXP-IVF height	mm	545	545	545	545	545	545	545	545	545	545	545
MVP-MVT-MXP-MXT Feet height	mm	100	100	100	100	100	100	100	100	100	100	100
P - MXP-MXT-MVP-MVT Depth	mm	220	220	220	220	220	220	220	220	220	220	220
P - IVP-IXP-IVF Depth	mm	212	212	212	212	212	212	212	212	212	212	212
MXP-MXT-MVP-MVT Weight	kg	20	20,5	21	22	28	29	35	36	37	38	38
IVP-IXP-IVF Weight	kg	16,5	17	20,5	21,5	25,5	27	34,5	35,5	36,5	37,5	37,5

Data at the following conditions:

- ❶ Air: 27°C D.B.; 19°C W.B. - Acqua: 7/12°C.
- ❷ Air: 20°C - Water: 45/40°C.
- ❸ Air: 20°C - Water: 50°C, flow rate as in cooling.
- ❹ Air: 20°C - Water: 70/60°C.

- ❺ Air: 20°C - Water: 65/55°C.
- ❻ For room volume equal to 100 m³ and reverberation time = 0.5 sec.
- E Eurovent certificated performance.
MAX, MED, MIN speed with 10 Vdc, 6 Vdc, 1 Vdc input.
YARDY-I EV3 24 - 34 - 48 - 74 - 88 with oversized 4-row coil.

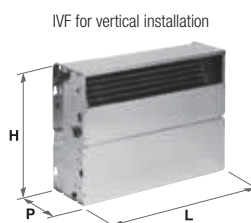
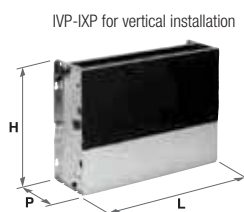
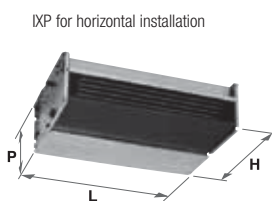

Fan coils

YARDY EV3

Cooling capacity: 1.1÷8.5 kW - Heating capacity: 1.6÷11.7 kW



- Enhanced performance with 4 row coil
- Acoustic comfort
- 6 speed fan
- Installation flexibility
- Pre-fitted accessories and controls

Floor, or ceiling, recessed wall or false ceiling installation fan coils with cabinet.

Construction features

- Heat exchanger: finned coil with left-hand connections reversible to right.
- 6-speed centrifugal fan, of which 3 speeds are connected to the terminal board.
- Cover cabinet version structure: covering cabinet in pre-painted sheet metal complete with renewable filter, ABS polymer grilles and condensation drain pan with natural drainage.
- Recessed version structure: in galvanised sheet steel, complete with condensation drain pan with natural drainage and renewable filter.

Versions

- MVP - Vertical unit with cabinet equipped with lower air inlet and upper outlet for wall mounting or with feet on ground.
- MVT - Vertical unit with cabinet equipped with front air inlet and upper outlet for floor installation.
- MXP - Horizontal/vertical unit with cabinet, equipped with lower air inlet and upper outlet, for ceiling installation, wall-mounting or with feet on ground.
- MXT - Vertical unit with cabinet equipped with front air inlet and upper outlet for floor installation.
- IVP - Vertical unit with cabinet equipped with front air inlet and upper outlet for floor installation.
- IVF - Recessed vertical unit equipped with lower air inlet and front outlet for wall installation.
- IXP - Horizontal/vertical unit equipped with lower air inlet and upper outlet for false ceiling or recessed wall installation.





YARDY EV3 MVP-MVT-MXP-MXT-IVP-IVF-IXP		15	20	24	25	30	34	40	45	48	55	58	60	74	80	88
DIMENSIONS AND WEIGHTS																
L - MXP-MXT-MVP-MVT width	mm	700	800	800	1000	1000	1000	1200	1200	1200	1500	1500	1500	1500	1500	1500
L - IVP-IXP-IVF width	mm	450	550	550	750	750	750	950	950	950	1250	1250	1250	1250	1250	1250
H - MXP-MXT-MVP-MVT height	mm	570	570	570	570	570	570	570	570	570	570	570	570	570	570	570
H - IVP-IXP-IVF height	mm	545	545	545	545	545	545	545	545	545	545	545	545	545	545	545
MVP-MVT-MXP-MXT Feet height	mm	100	100	100	100	100	100	100	100	100	100	100	100	100	100	100
P - MXP-MXT-MVP-MVT Depth	mm	220	220	220	220	220	220	220	220	220	220	220	220	220	220	220
P - IVP-IXP-IVF Depth	mm	212	212	212	212	212	212	212	212	212	212	212	212	212	212	212
MXP-MXT-MVP-MVT Weight	kg	16	20	20,5	20	21	22	27	28	29	35	35	35	36	37	38
IVP-IXP-IVF Weight	kg	14,5	16,5	17	20,5	20,5	21,5	24	25,5	27	34,5	34,5	34,5	35,5	36,5	37,5

Accessories

- ❖Additional water heating coil.
- ❖Electrical heater.
- ❖ON/OFF 2-way valves for 2 and 4-pipe systems.
- ❖ON/OFF 3-way valves for 2 and 4-pipe systems.
- ❖Auxiliary condensation drain pan.
- Manual damper.
- Motorised damper.
- Rear panel.
- Rear closure panel.
- Rear closure panel with grille and filter.
- Support feet with pipe cover.

STANDARD Controls

For wall mounting installation

- Panel with speed and summer/winter switch.
- Panel with room thermostat, summer/winter switch, speed switch, ON/OFF valve signal and electrical heater.
- Minimum temperature thermostat (for installation on the machine).
- Electronic panel with automatic summer/winter changeover for 2-pipe systems.



- Electronic panel with automatic summer/winter changeover and automatic speed regulation for 2-pipe systems with electrical resistance or 4-pipe systems.
- Electronic panel with display and RS485 serial interface, semi-recessed in wall.

For installation on machine (MVP and MVT versions)

- ❖Panel with speed and summer/winter switch.
- ❖Panel with room thermostat, summer/winter switch and speed switch.
- ❖Minimum temperature thermostat.
- ❖Panel with room thermostat, summer/winter switch, speed switch, ON/OFF valve signal and electrical heater.
- ❖Electronic panel with automatic summer/winter changeover for 2-pipe systems.
- ❖Electronic panel with automatic summer/winter changeover and automatic speed regulation for 2-pipe systems with electrical resistance or 4-pipe systems.
- Interface board for controlling up to 4 fan coils.

IDRHOSS CONTROLS

- Wall mounting receiver with remote control.
- Electronic panel for wall or on board mounting.
- Wall-mounted recessed electronic panel.

For installation on machine

- ❖Master/slave electronic board.
- ❖Temperature probe for hot row.
- ❖Module for ON/OFF valves and electrical heater management.
- RS485 interface for serial communication with other devices (proprietary protocol; Modbus RTU protocol).
- RS485/USB serial converter.
- Serial interface (CAN-bus - Controller Area Network) for the IDRHOSS system.
- KGTW-BAC- Gateway RS485/BACnet (max 64 fan coil).
- KGW-LON- Gateway RS485/FTT10-LonWorks (max 64 fan coil).

Key: ❖ Factory fitted
 → Supplied loose

MXP for horizontal installation

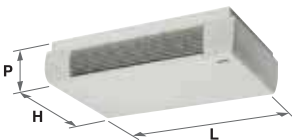

MXT for horizontal installation



MVP-MXP for vertical installation



MVP-MXP+feet

MVT-MXT for vertical installation



IXP for horizontal installation

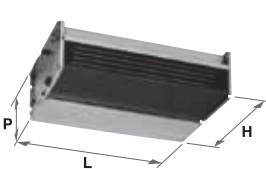

IVP-IXP for vertical installation

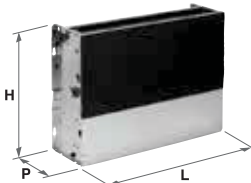

IVF for vertical installation

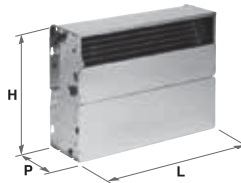

YARDY EV3 MVP-MVT-MXP-MXT-IVF-IVF-IXP		15	20	24	25	30	34	40	45	48	55	58	60	74	80	88
① Total cooling capacity	VI	kW 1,14	2,02	2,24	2,54	3,27	3,34	3,79	4,33	4,84	5,49	6,01	6,69	7,16	8	8,45
	V	kW 1,07	1,8	2,13	2,27	2,85	3,11	3,42	3,9	4,53	4,95	5,36	6,22	6,61	7,69	8,11
	IV	kW 0,99	1,56	1,89	2,05	2,61	2,85	2,88	3,35	3,61	4,48	4,85	5,54	6,13	7,26	7,54
	III	kW 0,91	1,39	1,7	1,71	2,49	2,58	2,66	3,03	3,39	3,97	4,31	5,37	5,8	6,9	7,46
	II	kW 0,78	1,2	1,47	1,64	2,1	2,28	2,5	2,84	3,14	3,39	3,62	4,49	5,15	6,43	6,96
① Total cooling capacity [EN1397]	I	kW 0,65	1,14	1,36	1,4	1,8	2	2,09	2,52	2,88	2,73	3,07	4,31	4,73	6,36	6,61
	VI	kW 1,1	1,98	2,2	2,5	3,21	3,28	3,72	4,26	4,76	5,38	5,87	6,53	6,99	7,82	8,25
	V	kW 1,03	1,76	2,1	2,24	2,8	3,05	3,36	3,84	4,46	4,86	5,24	6,09	6,48	7,52	7,93
	IV	kW 0,96	1,54	1,87	2,02	2,57	2,81	2,84	3,31	3,57	4,4	4,75	5,42	6,01	7,12	7,39
	III	kW 0,88	1,37	1,68	1,69	2,46	2,55	2,63	2,99	3,35	3,9	4,23	5,26	5,68	6,77	7,32
② Heating capacity (45°C) [EN1397]	II	kW 0,76	1,18	1,45	1,62	2,07	2,25	2,47	2,81	3,11	3,34	3,56	4,4	5,05	6,31	6,83
	I	kW 0,63	1,13	1,35	1,38	1,78	1,98	2,06	2,49	2,85	2,69	3,03	4,22	4,63	6,24	6,49
	VI	kW 1,38	2,26	2,36	2,97	3,59	3,78	4,37	4,68	4,9	6,14	7,19	7,53	7,89	8,71	10,05
	V	kW 1,21	1,97	2,04	2,68	3,29	3,45	3,79	4,27	4,45	5,46	6,74	7,04	7,37	8,25	9,61
	IV	kW 1,08	1,62	1,73	2,31	2,85	2,98	3,22	3,47	3,63	4,89	5,93	6,2	6,48	8,16	9,12
③ Heating capacity (50°C)	III	kW 1,06	1,47	1,52	1,94	2,65	2,79	2,97	3,21	3,34	4,13	5,81	6,02	6,3	7,8	9
	II	kW 0,92	1,26	1,44	1,85	2,26	2,36	2,77	2,81	2,93	3,57	5,12	5,29	5,49	7,12	8,22
	I	kW 0,72	1,24	1,27	1,57	2,02	2,2	2,52	2,6	2,69	2,94	4,6	4,71	4,92	7,05	8,15
	VI	kW 1,59	2,65	2,78	3,47	4,21	4,42	5,11	5,51	5,79	7,17	8,34	8,78	9,22	10,19	11,68
	V	kW 1,4	2,31	2,43	3,14	3,85	4,04	4,45	5,03	5,28	6,39	7,81	8,22	8,63	9,67	11,17
④ Heating capacity (70°C) [EN1397]	IV	kW 1,25	1,91	2,06	2,71	3,36	3,53	3,79	4,11	4,32	5,74	6,89	7,25	7,61	9,55	10,62
	III	kW 1,23	1,74	1,83	2,28	3,14	3,3	3,5	3,79	3,98	4,87	6,69	7,04	7,39	9,13	10,49
	II	kW 1,07	1,49	1,72	2,18	2,67	2,8	3,26	3,35	3,52	4,22	5,85	6,16	6,47	8,35	9,6
	I	kW 0,84	1,46	1,53	1,84	2,37	2,59	2,93	3,08	3,23	3,47	5,24	5,52	5,8	8,26	9,49
	VI	kW 2,74	4,51	4,71	5,94	7,17	7,54	8,75	9,34	9,77	12,26	14,34	15,02	15,74	17,38	20,05
⑤ Heating capacity of additional coil (65°C) [EN1397]	V	kW 2,41	3,94	4,08	5,37	6,57	6,88	7,59	8,53	8,89	10,9	13,46	14,05	14,72	16,47	19,17
	IV	kW 2,14	3,24	3,45	4,62	5,71	5,97	6,46	6,93	7,27	9,78	11,84	12,39	12,94	16,31	18,22
	III	kW 2,11	2,96	3,06	3,88	5,32	5,6	5,96	6,41	6,69	8,26	11,61	12,02	12,59	15,6	17,99
	II	kW 1,84	2,54	2,9	3,72	4,54	4,77	5,57	5,63	5,89	7,17	10,25	10,57	11,06	14,24	16,44
	I	kW 1,44	2,51	2,57	3,15	4,06	4,45	5,05	5,19	5,42	5,97	9,27	9,45	9,95	14,09	16,29
④ Heating capacity of additional coil (70°C)	VI	kW 1,37	2,09	1,77	2,7	3,2	3,05	3,68	3,51	3,34	5,48	5,14	5,7	5,44	6,5	6,26
	V	kW 1,25	1,93	1,69	2,61	2,69	2,56	3,03	3,38	3,22	5,15	5	5,56	5,28	6,46	6,2
	IV	kW 1,19	1,81	1,46	2,28	2,61	2,47	2,9	2,97	2,82	4,6	4,68	5,21	4,96	6,36	6,06
	III	kW 1,05	1,51	1,33	2,0	2,28	2,17	2,82	2,79	2,65	4,27	4,34	4,91	4,62	5,9	5,92
	II	kW 0,96	1,4	1,2	1,84	2,15	2,04	2,76	2,74	2,6	3,6	3,72	4,71	3,96	5,7	5,75
⑤ Sound power	I	kW 0,87	1,29	1,16	1,69	1,93	1,83	2,62	2,21	2,1	3,16	3,25	4,22	3,53	5,3	5,28
	VI	kW 1,55	2,33	1,97	3,01	3,56	3,38	4,11	3,91	3,71	6,08	5,66	6,29	5,98	7,18	6,88
	V	kW 1,41	2,16	1,9	2,92	2,99	2,84	3,4	3,78	3,59	5,73	5,54	6,16	5,85	7,14	6,82
	IV	kW 1,35	2,06	1,65	2,55	2,91	2,76	3,32	3,4	3,23	5,13	5,19	5,77	5,48	7,06	6,71
	III	kW 1,19	1,72	1,52	2,24	2,55	2,43	3,24	3,19	3,03	4,76	4,83	5,45	5,1	6,55	6,56
⑥ Sound pressure	II	kW 1,09	1,6	1,37	2,06	2,4	2,28	3,17	3,15	2,99	4,02	4,15	5,23	4,38	6,33	6,38
	I	kW 0,98	1,47	1,33	1,9	2,15	2,04	3,02	2,54	2,41	3,58	3,68	4,68	3,89	5,88	5,86
	VI	m³/h 229	339	339	484	547	547	676	681	681	1077	1077	1235	1235	1480	1480
	V	m³/h 209	288	288	405	483	483	587	627	627	916	916	1109	1109	1388	1388
	IV	m³/h 183	238	238	339	434	434	472	474	474	802	802	948	948	1220	1220
Absorbed power	III	m³/h 163	207	207	281	383	383	419	431	431	662	662	882	882	1171	1171
	II	m³/h 138	177	177	252	329	321	390	392	392	537	537	757	757	1031	1031
	I	m³/h 100	155	155	217	281	281	365	338	338	420	420	672	672	994	994
	VI	dB(A) 46	48	48	48	50	50	51	52	52	58	58	62	62	66	66
	V	dB(A) 43	44	44	42	47	47	48	50	50	56	56	60	60	65	65
⑥ Sound pressure	IV	dB(A) 40	41	40	38	43	43	43	43	43	52	54	56	56	62	62
	III	dB(A) 37	35	35	33	40	40	40	41	41	47	47	54	54	61	61
	II	dB(A) 32	34	32	30	36	36	38	38	38	41	41	50	50	59	59
	I	dB(A) 26	30	31	26	34	34	35	35	35	36	36	48	48	57	57
	VI	dB(A) 37	39	39	39	41	41	42	43	43	49	49	53	53	57	57
⑥ Sound pressure	V	dB(A) 34	35	35	33	38	38	39	41	41	47	47	51	51	56	56
	IV	dB(A) 31	32	31	29	34	34	34	34	34	43	45	47	47	53	53
	III	dB(A) 28	26	26	24	31	31	31	32	32	38	38	45	45	52	52
	II	dB(A) 23	25	23	21	27	27	29	29	29	32	32	41	41	50	50
	I	dB(A) 17	21	22	17	25	25	26	26	26	27	27	39	39	48	48
Electrical supply	VI	W 40	40	41	45	60	65	72	70	76	115	145	161	172	184	197
	V	W 39	36	32	34	54	58	58	61	66	95	122	130	133	143	185
	IV	W 31	25	25	26	36	39	42	41	44	81	102	117	125	142	152
	III	W 28	23	21	22	31	33	34	36	39	66	83	109	117	133	142
	II	W 23	17	16	17	27	27	33	31	33	51	64	95	102	124	133
I	W 17	15	14	16	25	25	28	28	30	41	44	92	98	116	124	

Data at the following conditions:

① Air: 27°C D.B.; 19°C W.B. - Acqua: 7/12°C.

② Air: 20°C - Water: 45/40°C.

③ Air: 20°C - Water: 50°C, flow rate as in cooling.

④ Air: 20°C - Water: 70/60°C.

⑤ Air: 20°C - Water: 65/55°C.

⑥ For room volume equal to 100 m³ and reverberation time = 0.5 sec.

• Wired speed in terminal block.

E Eurovent certificated performance.

Yardy EV3 24 - 34 - 48 - 74 - 88 with oversized 4-row coil.



Ductable fan coils with brushless motor

YARDY-ID2

Cooling capacity: 2.4÷6.4 kW - Heating capacity: 3.0÷8.7 kW

The logo for the inverter feature, consisting of the word "INVERTER" in a bold, blue, sans-serif font. To the left of the text is a stylized graphic of three overlapping, concentric, curved lines in shades of blue and orange, resembling a fan or a signal wave.

- 50% lower consumption with respect to traditional motor
- Continuous fan speed variation
- Quieter operation
- Better room comfort

Ductable fan coil units for recessed horizontal or vertical installation

Construction features

- Heat exchanger: finned coil with left-hand connections reversible to right.
- Centrifugal fan with an inverter controlled brushless electronic motor and continuous speed adjustment.
- Structure: made of galvanised sheet steel complete with condensation drain pan with natural drainage and renewable filter.
- Standard or enhanced configuration setting by means of KCM electronic board digital input.

Versions

- CXP - Recessed unit for horizontal or vertical installation (with lower inlet and upper outlet).

Accessories

- Additional water heating coil.
- Electrical heater.
- Valve and balancing valve.
- ON/OFF 2-way electrovalve for 2-pipe and 4-pipe systems.
- ON/OFF 3-way electrovalve for 2-pipe and 4-pipe systems.
- Auxiliary condensation drain pan.
- Motorised damper.
- Frame with filter (G2) that can be extracted in any direction.
- Straight outlet connection.
- 90° outlet and inlet connection.
- Telescopic outlet/inlet connection.
- Inlet grille with filter.
- Outlet grille.
- Flange frame for duct connection.
- Anti-vibration connection for outlet/inlet duct connection.
- Inlet/outlet plenum with circular nozzles.

STANDARD Controls

For wall mounting installation

- Electronic panel with display and RS485 serial interface, semi-recessed in wall.



iDRHOSS CONTROLS

- Wall mounting receiver with remote control.
- Electronic panel for wall mounting installation.
- Wall-mounted recessed electronic panel.

For installation on machine

- Master/slave electronic board, valve control module ON/OFF and electrical heater, temperature probe for hot row.
- RS485 interface for serial communication with other devices (proprietary protocol; Modbus RTU protocol).
- RS485/USB serial converter.
- Serial interface (CAN-bus - Controller Area Network) for the iDRHOSS system.
- KGTW-BAC- Gateway RS485/BACnet (max 64 fan coil).
- KGW-LON- Gateway RS485/FTT10-LonWorks (max 64 fan coil).

- Key:
- Factory fitted
 - Supplied loose



YARDY-ID2 CXP		40		48		60		74		80		88									
Configuration (*)		STANDARD	ENHANCED	STANDARD	ENHANCED	STANDARD	ENHANCED	STANDARD	ENHANCED	STANDARD	ENHANCED	STANDARD	ENHANCED								
❶	Total cooling capacity	MAX	kW	2,42	3,08	2,65	3,35	3,37	4,22	3,9	4,68	4,75	6,02	5,1	6,4						
		MED	kW	2,05	2,76	2,28	3,01	3,09	3,58	3,57	4,5	3,84	5,42	4,3	5,8						
		MIN	kW	1,2	1,2	1,29	1,29	1,59	1,59	1,73	1,73	2,04	2,04	2,3	2,3						
❶	Total cooling capacity [EN1397]	MAX	kW	2,36	3,01	E	2,58	3,28	E	3,29	4,12	E	3,81	4,58	E	5	6,26	E			
		MED	kW	2,01	2,7	E	2,24	2,95	E	3,03	3,5	E	3,5	4,42	E	3,79	5,32	E	4,25	5,7	E
		MIN	kW	1,19	1,19	E	1,28	1,28	E	1,58	1,58	E	1,72	1,72	E	2,03	2,03	E	2,29	2,29	E
❷	Heating capacity (45°C) [EN1397]	MAX	kW	2,57	3,29	E	2,6	3,34	E	3,84	4,73	E	3,83	4,77	E	5,66	7,37	E	5,75	7,48	E
		MED	kW	2,16	2,93	E	2,17	2,97	E	3,47	4,53	E	3,46	4,48	E	4,62	6,6	E	4,65	6,71	E
		MIN	kW	1,16	1,16	E	1,18	1,18	E	1,58	1,58	E	1,61	1,61	E	2,49	2,49	E	2,5	2,5	E
❸	Heating capacity (50°C)	MAX	kW	3	3,86	E	3,06	3,94	E	4,46	5,52	E	4,55	5,63	E	6,58	8,55	E	6,71	8,72	E
		MED	kW	2,54	3,44	E	2,59	3,51	E	4,05	5,23	E	4,13	5,33	E	5,39	7,69	E	5,5	7,84	E
		MIN	kW	1,39	1,39	E	1,42	1,42	E	1,9	1,9	E	1,94	1,94	E	2,92	2,92	E	2,98	2,98	E
❹	Heating capacity (70°C) [EN1397]	MAX	kW	5,1	6,56	E	5,19	6,65	E	7,72	9,44	E	7,81	9,62	E	11,3	14,72	E	11,54	14,93	E
		MED	kW	4,31	5,84	E	4,38	5,92	E	7,02	9,04	E	7,07	9,1	E	9,3	13,21	E	9,47	13,42	E
		MIN	kW	2,35	2,35	E	2,39	2,39	E	3,24	3,24	E	3,27	3,27	E	5,1	5,1	E	5,13	5,13	E
❺	Heating capacity of additional coil (65°C) [EN1397]	MAX	kW	2,29	2,76	E	2,18	2,62	E	3,57	4,16	E	3,39	4,32	E	4,55	5,71	E	4,33	5,43	E
		MED	kW	2,01	2,52	E	1,92	2,4	E	3,3	3,99	E	3,15	3,7	E	3,89	5,11	E	3,69	5,03	E
		MIN	kW	1,28	1,28	E	1,22	1,22	E	1,91	1,91	E	1,91	1,91	E	2,42	2,42	E	2,3	2,3	E
❻	Heating capacity of additional coil (70°C)	MAX	kW	2,59	3,12	E	2,46	2,96	E	3,94	4,61	E	3,74	4,78	E	5,04	6,32	E	4,79	6	E
		MED	kW	2,3	2,86	E	2,19	2,72	E	3,67	4,43	E	3,49	4,10	E	4,35	5,68	E	4,13	5,59	E
		MIN	kW	1,47	1,47	E	1,4	1,4	E	2,2	2,2	E	2,19	2,19	E	2,78	2,78	E	2,64	2,64	E
❼	Available static Air flow rate / Pressure	MAX	m³/h / Pa	350 / 70	469 / 64	E	350 / 70	469 / 64	E	573 / 61	737 / 56	E	573 / 61	737 / 56	E	767 / 76	1010 / 65	E	738 / 74	949 / 64	E
		MED	m³/h / Pa	291 / 50	410 / 50	E	291 / 50	410 / 50	E	512 / 50	691 / 50	E	512 / 50	691 / 50	E	606 / 50	866 / 50	E	594 / 50	831 / 50	E
		MIN	m³/h / Pa	150 / 8	150 / 8	E	150 / 8	150 / 8	E	214 / 6	214 / 6	E	214 / 6	214 / 6	E	284 / 7	284 / 7	E	284 / 7	284 / 7	E
❼	Delivery sound power	MAX	dB(A)	51	56	E	51	56	E	55	57	E	55	57	E	57	58	E	57	58	E
		MED	dB(A)	48	52	E	47	52	E	52	56	E	52	56	E	56	57	E	56	57	E
		MIN	dB(A)	30	30	E	30	30	E	30	30	E	30	30	E	30	30	E	30	30	E
❼	Delivery sound pressure	MAX	dB(A)	42	47	E	42	47	E	46	48	E	46	48	E	48	49	E	48	49	E
		MED	dB(A)	39	43	E	38	43	E	43	47	E	43	47	E	47	48	E	47	48	E
		MIN	dB(A)	21	21	E	21	21	E	21	21	E	21	21	E	21	21	E	21	21	E
❼	Absorbed power	MAX	W	65	69	E	67	72	E	85	100	E	89	105	E	105	140	E	105	140	E
		MED	W	38	60	E	38	63	E	65	80	E	68	84	E	75	100	E	75	100	E
		MIN	W	8	8	E	8	8	E	8	8	E	8	8	E	13	13	E	13	13	E
Electrical supply	V-ph-Hz	230-1-50		230-1-50		230-1-50		230-1-50		230-1-50		230-1-50									
DIMENSIONS AND WEIGHTS		40		48		60		74		80		88									
L - Width	mm	950		950		1250		1250		1250		1250									
H - Height	mm	545		545		545		545		545		545									
P - Depth	mm	212		212		212		212		212		212									
Weight	kg	25,5		26,5		34,5		35,5		36,5		37,5									

Data at the following conditions:

❶ Air: 27°C D.B.; 19°C W.B. - Acqua: 7/12°C.

❷ Air: 20°C - Water: 45/40°C.

❸ Air: 20°C - Water: 50°C, flow rate as in cooling.

❹ Air: 20°C - Water: 70/60°C.

❺ Air: 20°C - Water: 65/55°C.

❼ According to EN16583

❼ For room volume equal to 100 m³ and reverberation time = 0.5 sec.

E Eurovent certificated performance.

(*) The performance refers to the following configurations: STANDARD: 2/6.5/8 Vdc outlet at min/med/max speed; ENHANCED: 2/7/10 Vdc outlet at min/med/max speed.

Yardy ID2 48 - 74 - 88 with oversized 4-row coil.

YARDY-ID2 for horizontal and vertical installation

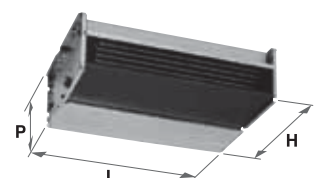

Ductable fan coils

YARDY-DUCT2

Cooling capacity: 2.0÷5.8 kW - Heating capacity: 2.4÷7.2 kW



- Enhanced performance with 4-row coil
- Six-speed ductable version
- Vertical and horizontal installation
- Remote control

Ductable fan coil units for recessed horizontal or vertical installation

Construction features

- Heat exchanger: finned coil with left-hand connections reversible to right.
- 6-speed centrifugal fan connected to the terminal board.
- Structure: made of galvanised sheet steel complete with condensation drain pan with natural drainage and renewable filter.

Versions

- CXP - Recessed unit for horizontal or vertical installation (with lower inlet and upper outlet).

Accessories

- ❖ Additional water heating coil.
- ❖ Electrical heater.
- ❖ ON/OFF 2-way electrovalve for 2-pipe and 4-pipe systems.
- ❖ ON/OFF 3-way electrovalve for 2-pipe and 4-pipe systems.
- ❖ Auxiliary condensation drain pan.
- Motorised damper.
- Frame with filter (G2) that can be extracted in any direction.
- Straight outlet connection.
- 90° outlet and inlet connection.
- Telescopic outlet/inlet connection.
- Inlet grille with filter.
- Outlet grille.
- Flanged frame for connection to intake or delivery channel.
- Anti-vibration connection for outlet/inlet duct connection.
- Inlet/outlet plenum with circular nozzles.

STANDARD Controls

For wall installation

- Panel with speed and summer/winter switch.
- Panel with room thermostat, summer/winter switch, speed switch, ON/OFF valve signal and electric heater.
- Minimum temperature thermostat (for installation on the machine).
- Electronic panel with automatic summer/winter switch for 2-pipe-systems.
- Electronic panel with automatic summer/winter switch and automatic speed regulation for 2-pipe-systems with electric heater or 4-pipe-systems.
- Interface board for controlling up to 4 fan coil units (for on board installation)
- Electronic panel with display and RS485 serial interface, semi-recessed in wall.

iDRHOSS CONTROLS

- Wall mounting receiver with remote control.
- Electronic panel for wall mounting installation.
- Wall-mounted recessed electronic panel.



For installation on machine

- ❖ Master/slave electronic board.
- ❖ Temperature probe for hot row.
- ❖ Module for ON/OFF valves and electrical heater management.
- RS485 interface for serial communication with other devices (proprietary protocol; Modbus RTU protocol).
- RS485/USB serial converter.
- Serial interface (CAN-bus - Controller Area Network) for the iDRHOSS system.
- KGTW-BAC- Gateway RS485/BACnet (max 64 fan coil).
- KGW-LON- Gateway RS485/FTT10-LonWorks (max 64 fan coil).

- Key:
- ❖ Factory fitted
 - Supplied loose
 - * Previous name



YARDY-DUCT2 CXP		40	48	50	60	74	80	88	
1	Total cooling capacity	VI kW	1,97	2,29	2,68	3,6	4,56	4,98	5,84
		V kW	1,82	2,12	2,47	3,43	4,37	4,74	5,66
		IV kW	1,54	1,73	2,32	3,27	4,09	4,51	5,53
		III kW	1,39	1,61	2	3,1	3,87	4,28	5,31
		II kW	1,27	1,47	1,75	2,73	3,5	4,01	5,04
		I kW	1,1	1,28	1,34	2,49	3,22	3,95	4,89
1	Total cooling capacity [EN1397]	VI kW	1,9E	2,22E	2,59E	3,47E	4,43E	4,83 E	5,69 E
		V kW	1,76E	2,06E	2,39	3,33	4,26	4,61	5,53
		IV kW	1,5	1,69	2,25E	3,18E	4E	4,38 E	5,42 E
		III kW	1,35E	1,57E	1,94	3,01	3,78	4,17	5,2
		II kW	1,24	1,44	1,7E	2,65E	3,42E	3,9 E	4,94 E
		I kW	1,07	1,25	1,3	2,42	3,14	3,86	4,8
2	Heating capacity (45°C) [EN1397]	VI kW	2,07E	2,15E	3E	4,11E	4,17E	5,77 E	6,12 E
		V kW	1,9E	1,96E	2,77	3,92	3,98	5,62	5,8
		IV kW	1,53	1,59	2,6E	3,69E	3,76E	5,51 E	5,74 E
		III kW	1,41E	1,46E	2,16	3,49	3,54	5,3	5,45
		II kW	1,27	1,33	1,89E	3,2E	3,26E	4,78 E	5,11 E
		I kW	1,11	1,16	1,55	2,94	2,98	4,61	5,06
3	Heating capacity (50°C)	VI kW	2,41	2,53	3,47	4,74	4,98	6,68	7,18
		V kW	2,21	2,32	3,21	4,52	4,75	6,51	6,84
		IV kW	1,8	1,89	3,02	4,29	4,5	6,37	6,76
		III kW	1,65	1,73	2,52	4,05	4,25	6,13	6,44
		II kW	1,5	1,58	2,21	3,7	3,89	5,53	6,04
		I kW	1,3	1,37	1,79	3,39	3,56	5,35	5,99
4	Heating capacity (70°C) [EN1397]	VI kW	4,12	4,3	6,01	8,21	8,49	11,48	12,23
		V kW	3,78	3,94	5,58	7,84	8,1	11,20	11,64
		IV kW	3,07	3,2	5,26	7,44	7,67	10,98	11,53
		III kW	2,82	2,93	4,39	7,04	7,24	10,56	10,99
		II kW	2,56	2,67	3,85	6,48	6,65	9,52	10,33
		I kW	2,22	2,32	3,15	5,96	6,08	9,20	10,26
5	Heating capacity of additional coil (65°C) [EN1397]	VI kW	1,97E	1,88E	3,19E	3,78E	3,6E	4,64 E	4,42 E
		V kW	1,84E	1,76E	2,99	3,75	3,58	4,45	4,24
		IV kW	1,7	1,61	2,85E	3,62E	3,45E	4,36 E	4,15 E
		III kW	1,51E	1,43E	2,5	3,52	3,36	4,25	4,05
		II kW	1,41	1,34	2,24E	3,41E	3,25E	4,16 E	3,95 E
		I kW	1,27	1,21	1,89	3,32	3,15	4,04	3,85
4	Heating capacity of additional coil (70°C)	VI kW	2,22	2,11	3,54	4,14	3,93	5,09	4,84
		V kW	2,08	1,98	3,34	4,12	3,91	4,9	4,66
		IV kW	1,93	1,83	3,2	4	3,8	4,8	4,56
		III kW	1,71	1,62	2,81	3,9	3,71	4,7	4,47
		II kW	1,6	1,52	2,53	3,8	3,61	4,59	4,36
		I kW	1,44	1,37	2,14	3,72	3,53	4,48	4,26
Available static Air flow rate / Pressure	VI m³/h	275 / 56E	275 / 56E	450 / 69E	620 / 66E	620 / 66E	912 / 62 E	862 / 62 E	
	V m³/h	250 / 50E	250 / 50E	411 / 58	587 / 59	587 / 59	858 / 54	828 / 54	
	IV m³/h	198 / 33	198 / 33	382 / 49E	539 / 50E	539 / 50E	820 / 50 E	800 / 50 E	
	III m³/h	180 / 19E	180 / 28E	315 / 36	504 / 44	504 / 44	772 / 45	759 / 45	
	II m³/h	163 / 16	163 / 24	270 / 26E	445 / 34E	445 / 34E	715 / 39 E	708 / 39 E	
	I m³/h	140 / 9	140 / 18	210 / 19	402 / 28	402 / 28	685 / 35	680 / 35	
6	Delivery sound power	VI dB(A)	50E	50E	48E	56E	54E	57 E	57 E
		V dB(A)	48E	48E	46	55	53	55	55
		IV dB(A)	43	43	45E	54E	51E	54 E	54 E
		III dB(A)	42E	42E	42	51	50	53	53
		II dB(A)	38	38	40E	50E	47E	51 E	51 E
		I dB(A)	37	37	38	48	46	50	50
7	Delivery sound pressure	VI dB(A)	41	41	39	47	45	48	48
		V dB(A)	39	39	37	46	44	46	46
		IV dB(A)	34	34	36	45	42	45	45
		III dB(A)	33	33	33	42	41	44	44
		II dB(A)	29	29	31	41	38	42	42
		I dB(A)	28	28	29	39	37	41	41
Absorbed power	VI W	68E	71E	94E	128E	134E	154 E	154 E	
	V W	60E	63E	78	120	126	134	134	
	IV W	41	43	71E	91E	95E	127 E	127 E	
	III W	36E	38E	60	88	93	109	109	
	II W	32	34	49E	84E	89E	105 E	105 E	
	I W	27	28	39	77	80	91	91	
Electrical supply	V-ph-Hz	230-1-50	230-1-50	230-1-50	230-1-50	230-1-50	230-1-50	230-1-50	
DIMENSIONS AND WEIGHTS		40	48	50	60	74	80	88	
L - Width	mm	950	950	1250	1250	1250	1250	1250	
H - Height	mm	545	545	545	545	545	545	545	
P - Depth	mm	212	212	212	212	212	212	212	
Weight	kg	25,5	27	34,5	34,5	35,5	36,5	37,5	

Data at the following conditions:

1 Air: 27°C D.B.; 19°C W.B. - Acqua: 7/12°C.

2 Air: 20°C - Water: 45/40°C.

3 Air: 20°C - Water: 50°C, flow rate as in cooling.

4 Air: 20°C - Water: 70/60°C.

5 Air: 20°C - Water: 65/55°C.

6 According to EN16583

7 For room volume equal to 100 m³ and reverberation time = 0.5 sec.

E Eurovent certified performance.

YARDY-DUCT2 48 - 74 - 88 with oversized 4-row coil.

Ductable terminals

YARDY-HP

Cooling capacity: 7.2÷20.5 kW - Heating capacity: 9.6÷28.0 kW



- Horizontal and vertical installation
- New pan removable from below for cleaning
- Set up with 3, 4, 5-row coil
- Filters with different efficiency levels
- Remote control

Ductable terminals for recessed horizontal or vertical installation

Construction features

- Structure: self-supporting, in galvanised sheet steel for horizontal installation in a false ceiling or vertical recessed wall installation, complete with natural drainage condensation pan, flanges to fit to the inlet/outlet duct. Pan is removable from below. Filter supplied separately from the unit.
- Heat exchanger: with finned coil and electrical box for terminal block with reversible left connections, which can be switched right directly on site. Coil is removable from below.
- Double inlet centrifugal fan with directly coupled 3-speed motor. Fan unit is removable from below.

Versions

- CXP - Recessed unit for horizontal or vertical installation (with lower inlet and upper outlet)

Row number

- 3 Rows - Unit with 3-row coil; recessed horizontal/vertical unit for installation.
- 4 Rows - Unit with 4-row coil; recessed horizontal/vertical unit for installation.
- 5 Rows - Unit with 5-row coil (only models 250, 300); recessed horizontal/vertical unit for installation.

Accessories

- ❖ Additional water heating coil (1 row) for 4T-KBAA 4-pipe systems - only for 3R units with a 3-row coil.
- External plenum with additional water heating coil for 4-pipe systems (PBAB).
- ❖ ON/OFF 2-way electrovalve for 2-pipe and 4-pipe systems.
- ❖ On/OFF 3-way electrovalve for 2-pipe and 4-pipe systems.
- ❖ Auxiliary condensation drain pan.
- Frame with filter that can be extracted in any direction (efficiency rating G1/G2/G3).
- Straight outlet and inlet connection.
- 90° outlet and inlet connection.
- Flange for duct connection.
- Anti-vibration connection for connection to inlet/outlet duct.
- Panel with circular nozzles to be connected to the outlet/inlet connections.

STANDARD Controls

For wall mounting installation

- Panel with speed and summer/winter switch.
- Panel with room thermostat, summer/winter switch, speed switch, ON/OFF valve signal and electric heater.
- Electronic panel with automatic summer/winter switch for 2-pipe-systems.
- Electronic panel with automatic summer/winter switch and automatic speed regulation for 2-pipe-systems with electric heater or 4-pipe-systems.
- Air sensor with remote control option.
- Interface card for controlling up to 4 fan coil units (models 100-150-200 only, for on board installation).

iDRHOSS CONTROLS

- Wall mounting receiver with remote control.
- Electronic panel for wall mounting installation.
- Wall-mounted recessed electronic panel.

For installation on machine

- ❖ Master/slave electronic board.
- ❖ Temperature probe for hot row.
- ❖ Module for ON/OFF valves and electrical heater management.
- RS485 interface for serial communication with other devices (proprietary protocol; Modbus RTU protocol).
- RS485/USB serial converter.
- Serial interface (CAN-bus - Controller Area Network) for the iDRHOSS system.
- KGTW-BAC- Gateway RS485/BACnet (max 64 fan coil).
- KGW-LON- Gateway RS485/FTT10-LonWorks (max 64 fan coil).

- Key: ❖ Factory fitted
 → Supplied loose



YARDY HP CXP			100	150	200	250	300	
❶	Total cooling capacity	3R	kW	7,16	8,37	10,13	13,53	15,22
❶	Total cooling capacity [EN1397]	3R	kW	6,96	8,13	9,75	12,85	14,42
❷	Heating capacity (45°C) [EN1397]	3R	kW	8,37	10,22	12,56	17,02	19,5
❸	Heating capacity (50°C)	3R	kW	9,66	11,71	14,28	19,12	21,82
❶	Total cooling capacity	4R	kW	8,41	9,51	11,37	16,55	18,75
❶	Total cooling capacity [EN1397]	4R	kW	8,22	9,28	11,04	15,88	18
❷	Heating capacity (45°C) [EN1397]	4R	kW	9,31	10,92	13,33	19,59	22,61
❸	Heating capacity (50°C)	4R	kW	10,86	12,68	15,38	22,35	25,76
❶	Total cooling capacity	5R	kW	-	-	-	18,7	20,5
❶	Total cooling capacity [EN1397]	5R	kW	-	-	-	18,04	19,75
❷	Heating capacity (45°C) [EN1397]	5R	kW	-	-	-	21,83	24,61
❸	Heating capacity (50°C)	5R	kW	-	-	-	25,04	28,11
❹	Heating capacity of additional coil (70°C)	4T -KBAA	kW	6,69	6,78	9,35	10,44	11,31
❺	Heating capacity of additional coil (65°C) [EN1397]	4T -KBAA	kW	6,09	6,22	8,61	9,86	10,74
❹	Heating capacity of additional coil (70°C)	PBAB	kW	12,9	14,14	16,4	29,73	32,77
❺	Heating capacity of additional coil (65°C) [EN1397]	PBAB	kW	11,56	12,69	14,78	26,92	29,68
❻	Air flow rate/Speed static pressure (3R)	MAX	m³/h / Pa	1.552 / 60	1.840 / 60	2.339 / 60	3.312 / 60	3.875 / 60
		MED	m³/h / Pa	1.369 / 50	1.620 / 50	1.717 / 50	2.189 / 50	3.075 / 50
		MIN	m³/h / Pa	1.013 / 35	1.432 / 35	1.414 / 35	1.329 / 35	2.415 / 35
❼	Delivery sound power (3R)	MAX	dB(A)	61	62	62	63	68
		MED	dB(A)	59	61	60	59	64
		MIN	dB(A)	56	59	57	55	61
❸	Speed sound pressure (3R)	MAX	dB(A)	47	48	48	49	54
		MED	dB(A)	45	47	46	45	50
		MIN	dB(A)	42	45	43	41	47
Nominal spd absorbed power MAX	3R	W	200	245	380	680	800	
	4R	W	190	230	330	670	750	
	5R	W	-	-	-	660	750	
Maximum absorbed power (0 Pa)	3R	W	280	300	500	850	900	
Electrical supply		V-ph-Hz	230-1-50	230-1-50	230-1-50	230-1-50	230-1-50	
DIMENSIONS AND WEIGHTS			100	150	200	250	300	
L - Width	mm		1295	1295	1295	1295	1295	
H - Height	mm		250	250	285	335	335	
P - YARDY HP Depth	mm		555	555	670	720	720	
P - PBAB Depth	mm		200	200	200	200	200	
YARDY HP Weight	kg		38	38	46	57	57	

Data at the following conditions:

- ❶ Air: 27°C D.B.; 19°C W.B. - Acqua: 7/12°C.
- ❷ Air: 20°C - Water: 45/40°C.
- ❸ Air: 20°C - Water: 50°C, flow rate as in cooling.
- ❹ Air: 20°C - Water: 70/60°C.
- ❺ Air: 20°C - Water: 65/55°C.
- ❻ 3 row coil (3R) without filter.
- ❼ With G3 filter at the conditions specified in point 6 according to EN16583
- ❸ At 2 m from the air outflow point with directionality factor 2 and G3 filter.

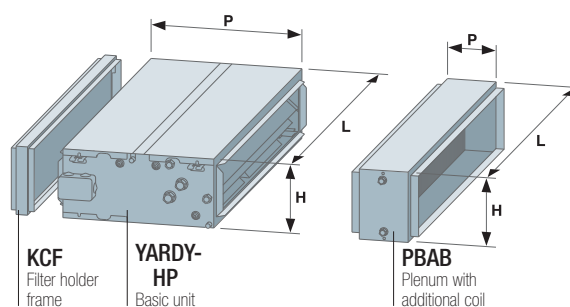

Fan coils with brushless motor

DIVA-I

Cooling capacity: 2.8÷10.8 kW - Heating capacity: 3.4÷12.7 kW

INVERTER



- Consumption reduced by 50% compared to the traditional motor
- Set ups for 2 pipe, 4 pipe or 2 pipes with electrical heater
- ABS or metal cover
- 3-way, On/OFF electrovalves and premounted controls on board

Cassette-type fan coil units

Construction features

- Fan coils: cassette-type for installation in false ceilings, with air return and flow directly into the room.
- Finned coil heat exchanger.
- Radial fan;
- Inverter brushless EC motor.
- Structure: self-supporting galvanised sheet steel complete with additional condensation drain pan and pump to lift the condensation (maximum head pressure 650mm).
- PLP ceiling plugging cover (accessory): in ABS polymer (RAL 9003) with manually adjustable outlet fins, inlet grille and renewable filter.

System type

- 2T - Cassette for 2-pipe systems.
- 4T - Cassette for 4 pipe systems.
- RE - Cassette for 2 pipe systems with integrative electrical heater.

Separately supplied accessories

- PLP-Ceiling cover in ABS (RAL 9003).
- PLM-Metal ceiling cover (RAL 9003) flush to the false ceiling, 60x60cm models only.
- On/OFF 3-way electrovalve for 2-pipe and 4-pipe systems.
- On/OFF 2-way electrovalve for 2-pipe and 4-pipe systems.
- Primary air duct connection.
- Shank for air distribution at a distance from the unit.
- Primary air kit.

STANDARD Controls

For wall mounting installation

- Electronic panel with display and RS485 serial interface, semi-recessed in wall.

iDRHOSS controls

- Remote control and receiver.
- Electronic panel for wall mounting installation.
- Wall-mounted recessed electronic panel.

For installation on machine

- Master/slave electronic board, valve control module ON/OFF and electrical heater, temperature probe for hot row.
- RS485 interface for serial communication with other devices (proprietary protocol; Modbus RTU protocol).
- RS485/USB serial converter
- Serial interface (CAN-bus - Controller Area Network) for the iDRHOSS system.
- KGTW-BAC- Gateway RS485/BACnet (max 64 fan coil).
- KGW-LON - Gateway RS485/FTT10-LonWorks (max 64 fan coil).

- Key: ♦ Factory fitted
 → Supplied loose



- Recessed control panel
- Remote control with bracket for wall installation
- Wall-mounted control panel



DIVA-I 2T - DIVA-I RE			30	40	50	60	110
❶ Total cooling capacity	MAX	kW	2,75	4,33	5,02	6,33	10,75
	MED	kW	2,17	3,05	3,87	5,15	7,72
	MIN	kW	1,84	2,24	2,56	4,21	5,29
❶ Total cooling capacity [EN1397]	MAX	kW E	2,73	4,3	4,96	6,3	10,69
	MED	kW E	2,16	3,04	3,85	5,13	7,69
	MIN	kW E	1,84	2,24	2,55	4,2	5,28
❷ Heating capacity (45°C) [EN1397]	MAX	kW E	2,87	4,36	5,15	6,7	10,56
	MED	kW E	2,22	2,98	3,85	5,3	7,34
	MIN	kW E	1,85	2,12	2,46	4,27	4,9
❸ Heating capacity (50°C)	MAX	kW	3,44	5,24	6,2	8,01	12,7
	MED	kW	2,67	3,58	4,63	6,35	8,83
	MIN	kW	2,22	2,55	2,96	5,11	5,89
❹ Heating capacity (70°C) [EN1397]	MAX	kW	5,81	8,81	10,47	13,5	21,34
	MED	kW	4,5	5,99	7,77	10,68	14,75
	MIN	kW	3,75	4,29	4,96	8,57	9,81
RE electrical resistance	230-1-50 V	kW	-	1,5	2,5	2,5	3
Air flow speed	MAX	m³/h	535	710	880	1165	1770
	MED	m³/h	380	445	610	870	1130
	MIN	m³/h	310	310	360	630	710
Sound power	MAX	dB(A) E	47	54	60	48	57
	MED	dB(A) E	39	43	50	39	47
	MIN	dB(A) E	33	33	37	33	34
❻ Sp. sound pressure	MAX	dB(A)	38	45	51	39	48
	MED	dB(A)	30	34	41	30	38
	MIN	dB(A)	24	24	28	24	25
Absorbed power	MAX	W E	16	31	62	33	108
	MED	W E	8	11	21	17	32
	MIN	W E	5	5	7	10	10
Electrical supply	V-ph-Hz		230-1-50	230-1-50	230-1-50	230-1-50	230-1-50
DIMENSIONS AND WEIGHTS			30	40	50	60	110
Cassette - Dimensions WxHxD	mm		575 x 275 x 575			820 x 303 x 820	
PLP Ceiling panelling - Dimensions WxHxD	mm		670x 67x 670			965 x 85 x 965	
Cassette - Weight	kg		22	24	24	36	39
PLP Ceiling panelling - Weight	kg		3	3	3	6	6

DIVA-I 4T			30	40	50	60	110
❶ Total cooling capacity	MAX	kW	2,77	3,93	4,53	6,51	9,87
	MED	kW	2,18	2,81	3,53	5,28	7,17
	MIN	kW	1,85	2,09	2,38	4,3	4,98
❶ Total cooling capacity [EN1397]	MAX	kW E	2,75	3,9	4,47	6,48	9,76
	MED	kW E	2,17	2,8	3,51	5,26	7,14
	MIN	kW E	1,85	2,09	2,37	4,29	4,97
❷ Heating capacity of additional coil (65°C) [EN1397]	MAX	kW E	3,18	2,91	3,29	8,24	8,33
	MED	kW E	2,51	2,2	2,66	6,65	6,27
	MIN	kW E	2,13	1,73	1,92	5,41	4,58
❹ Heating capacity of additional coil (70°C)	MAX	kW	3,62	3,35	3,79	9,36	9,51
	MED	kW	2,85	2,53	3,06	7,54	7,16
	MIN	kW	2,43	1,98	2,2	6,14	5,22
Air flow speed	MAX	m³/h	535	710	880	1165	1770
	MED	m³/h	380	445	610	870	1130
	MIN	m³/h	310	310	360	630	710
Sound power	MAX	dB(A) E	47	54	60	48	57
	MED	dB(A) E	39	43	50	39	47
	MIN	dB(A) E	33	33	37	33	34
❻ Sp. sound pressure	MAX	dB(A)	38	45	51	39	48
	MED	dB(A)	30	34	41	30	38
	MIN	dB(A)	24	24	28	24	25
Absorbed power	MAX	W E	16	31	62	33	108
	MED	W E	8	11	21	17	32
	MIN	W E	5	5	7	10	10
Electrical supply	V-ph-Hz		230-1-50	230-1-50	230-1-50	230-1-50	230-1-50
DIMENSIONS AND WEIGHTS			30	40	50	60	110
Cassette - Dimensions WxHxD	mm		575 x 275 x 575			820 x 303 x 820	
PLP Ceiling panelling - Dimensions WxHxD	mm		670x 67x 670			965 x 85 x 965	
Cassette - Weight	kg		22	24	24	36	39
PLP Ceiling panelling - Weight	kg		3	3	3	6	6

Data at the following conditions:

- ❶ Air: 27°C D.B.; 19°C W.B. - Acqua: 7/12°C.
 - ❷ Air: 20°C - Water: 45/40°C.
 - ❸ Air: 20°C - Water: 50°C, flow rate as in cooling.
 - ❹ Air: 20°C - Water: 70/60°C.
 - ❺ Air: 20°C - Water: 65/55°C.
 - ❻ For room volume equal to 100 m³ and reverberation time = 0.5 sec.
- E Eurovent certificated performance.

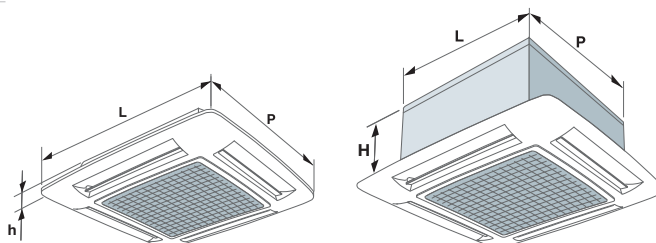

Fan coils

DIVA

Cooling capacity: 2.0÷11.1 kW - Heating capacity: 2.6÷14.0 kW



- Set ups for 2 pipe, 4 pipe or 2 pipes with electrical heater
- ABS or metal cover
- 3-way, On/OFF electrovalves and premounted controls on board

Cassette-type fan coil units

Construction features

- Fan coils: cassette-type for installation in false ceilings, with air return and flow directly into the room.
- Finned coil heat exchanger.
- Radial fan.
- 6-speed engine 3 of which are connected in a terminal board.
- Structure: self-supporting galvanised sheet steel complete with additional condensation drain pan and pump to lift the condensation (maximum head pressure 650mm).
- PLP ceiling plugging cover (accessory): in ABS polymer (RAL 9003) with manually adjustable outlet fins, inlet grille and renewable filter.

System type

- 2T - Cassette for 2-pipe systems.
- 4T - Cassette for 4 pipe systems.
- RE - Cassette for 2 pipe systems with integrative electrical heater.

Separately supplied accessories

- PLP-Ceiling panelling in ABS (RAL 9003).
- PLM-Metal ceiling panelling (RAL 9003) flush to the false ceiling, 60x60cm models only.
- ON/OFF 3-way electrovalve for 2 and 4-pipe systems.
- ON/OFF 2-way electrovalves for 2 and 4-pipe-systems.
- Primary air duct connection.
- Shank for air distribution at a distance from the unit.
- Primary air kit.

STANDARD Controls

For wall mounting installation

- Panel with speed and summer/winter switch.
- Panel with room thermostat, summer/winter switch, speed switch, ON/OFF valve signal and electrical heater.
- Electronic panel with automatic summer/winter changeover for 2-pipe systems.
- Electronic panel with automatic summer/winter changeover and automatic speed regulation for 2-pipe systems with electric heater or 4-pipe systems.
- Electronic panel with display and RS485 serial interface, semi-recessed in wall.
- Interface board for controlling up to 4 fan coils.

iDRHOSS Controls

- Remote control and receiver.
- Electronic control panel for wall mounting.
- Wall-mounted recessed electronic panel

For installation on machine.

- Master/slave electronic board.
- Temperature probe for hot row.
- Module for management of ON/OFF valves and electrical resistance.
- RS485 interface for serial communication with other devices (proprietary protocol; Modbus RTU protocol).
- RS 485/USB serial converter.
- Serial interface (CAN-bus - Controller Area Network) for the iDRHOSS system.
- KGTW-BAC- Gateway RS485/BACnet (max 64 fan coil).
- KGW-LON - Gateway RS485/FTT10-LonWorks (max 64 fan coil).

- Key: ♦ Factory fitted
 → Supplied separately



- Recessed control panel
- Remote control with bracket for wall installation
- Wall-mounted control panel



DIVA 2T - DIVA RE			20	30	40	50	60	90	110
❶ Total cooling capacity	MAX	kW	1,98	2,68	4,33	5,02	6,16	9,51	11,1
	MED	kW	1,63	2,34	3,34	3,88	4,91	6,78	8,45
	MIN	kW	1,27	1,84	2,25	2,94	4,21	5,31	5,31
❶ Total cooling capacity [EN1397]	MAX	kW E	1,92	2,64	4,26	4,93	6,08	9,39	10,93
	MED	kW E	1,6	2,31	3,3	3,82	4,86	6,72	8,36
	MIN	kW E	1,25	1,82	2,23	2,91	4,18	5,27	5,27
❷ Heating capacity (45°C) [EN1397]	MAX	kW E	2,24	2,8	4,37	5,15	6,5	9,23	11,72
	MED	kW E	1,8	2,42	3,28	3,85	5,03	6,4	8,55
	MIN	kW E	1,38	1,85	2,12	2,85	4,27	4,92	5,12
❸ Heating capacity (50°C)	MAX	kW	2,64	3,35	5,23	6,17	7,77	10,7	14
	MED	kW	2,12	2,9	3,93	4,63	6,03	7,34	10,3
	MIN	kW	1,62	2,22	2,56	3,43	5,12	5,61	6,13
❹ Heating capacity (70°C) [EN1397]	MAX	kW	4,55	5,68	8,83	10,44	13,15	17,94	23,7
	MED	kW	3,62	4,91	6,61	7,81	10,17	12,24	17,36
	MIN	kW	2,79	3,77	4,32	5,76	8,61	9,33	10,27
RE electrical resistance	230-1-50 V	kW	-	1,5	2,5	2,5	3	3	3
Air flow speed	MAX	m³/h	610	520	710	880	1140	1500	1820
	MED	m³/h	420	420	500	610	820	970	1280
	MIN	m³/h	310	310	320	430	630	710	710
Sound power	MAX	dB(A) E	49	45	53	59	48	53	58
	MED	dB(A) E	40	40	45	49	40	40	48
	MIN	dB(A) E	33	33	33	41	33	34	34
❻ Sp. sound pressure	MAX	dB(A)	40	36	44	50	39	44	49
	MED	dB(A)	31	31	36	40	31	31	39
	MIN	dB(A)	24	24	24	32	24	25	25
Absorbed power	MAX	W E	57	44	68	90	77	120	170
	MED	W E	32	32	44	57	48	63	95
	MIN	W E	25	25	25	32	33	42	42
Electrical supply	V-ph-Hz	230-1-50	230-1-50	230-1-50	230-1-50	230-1-50	230-1-50	230-1-50	230-1-50
DIMENSIONS AND WEIGHTS			20	30	40	50	60	90	110
Cassette - Dimensions WxHxD	mm			575 x 275 x 575				820 x 303 x 820	
PLP Ceiling panelling - Dimensions WxHxD	mm			670x 67x 670				965 x 85 x 965	
Cassette - Weight	kg		22	22	24	24	36	39	39
PLP Ceiling panelling - Weight	kg		3	3	3	3	6	6	6

DIVA 4T			20	30	32	40	42	50	60	80	90	92	110
❶ Total cooling capacity	MAX	kW	2,33	2,7	3,34	3,93	3,81	4,53	6,34	7,71	8,77	8,89	10,2
	MED	kW	1,96	2,36	2,65	3,06	3,02	3,53	5,03	5,66	6,33	6,93	7,84
	MIN	kW	1,51	1,85	1,85	2,09	2,36	2,72	4,14	4,52	4,99	4,52	4,99
❶ Total cooling capacity [EN1397]	MAX	kW E	2,27	2,66	3,27	3,86	3,72	4,44	6,26	7,59	8,65	8,72	10,03
	MED	kW E	1,93	2,33	2,61	3,02	2,96	3,47	4,98	5,6	6,27	6,84	7,75
	MIN	kW E	1,49	1,83	1,83	2,07	2,33	2,69	4,11	4,48	4,95	4,48	4,95
❷ Heating capacity of additional coil (65°C) [EN1397]	MAX	kW E	2,66	3,04	3,86	2,91	4,19	3,29	8,02	9,66	7,5	11,16	8,58
	MED	kW E	2,23	2,66	3,04	2,43	3,33	2,66	6,33	7,15	5,63	8,8	6,78
	MIN	kW E	1,72	2,13	2,13	1,73	2,61	2,14	5,21	5,69	4,59	5,69	4,59
❹ Heating capacity of additional coil (70°C)	MAX	kW	3,03	3,46	4,4	3,35	4,95	3,79	9,1	11	8,56	12,7	9,8
	MED	kW	2,54	3,02	3,46	2,71	3,97	3,06	7,19	8,1	6,42	9,98	7,74
	MIN	kW	1,96	2,43	2,43	1,98	3,1	2,46	5,91	6,45	5,23	6,45	5,23
Air flow speed	MAX	m³/h	610	520	710	710	880	880	1140	1500	1500	1820	1820
	MED	m³/h	420	420	500	500	610	610	820	970	970	1280	1280
	MIN	m³/h	310	310	320	320	430	430	630	710	710	710	710
Sound power	MAX	dB(A) E	49	45	53	53	59	59	48	53	53	58	58
	MED	dB(A) E	40	40	45	45	49	49	40	40	40	48	48
	MIN	dB(A) E	33	33	33	33	41	41	33	34	34	34	34
❻ Sp. sound pressure	MAX	dB(A)	40	36	44	44	50	50	39	44	44	49	49
	MED	dB(A)	31	31	36	36	40	40	31	31	31	39	39
	MIN	dB(A)	24	24	24	24	32	32	24	25	25	25	25
Absorbed power	MAX	W E	57	44	68	68	90	90	77	120	120	170	170
	MED	W E	32	32	44	44	57	57	48	63	63	95	95
	MIN	W E	25	25	25	25	32	32	33	42	42	42	42
Electrical supply	V-ph-Hz	230-1-50	230-1-50	230-1-50	230-1-50	230-1-50	230-1-50	230-1-50	230-1-50	230-1-50	230-1-50	230-1-50	230-1-50
DIMENSIONS AND WEIGHTS			20	30	32	40	42	50	60	80	90	92	110
Cassette - Dimensions WxHxD	mm			575 x 275 x 575				820 x 303 x 820					
PLP Ceiling panelling - Dimensions WxHxD	mm			670x 67x 670				965 x 85 x 965					
Cassette - Weight	kg		24	24	24	24	24	24	39	39	39	39	39
PLP Ceiling panelling - Weight	kg		3	3	3	3	3	3	6	6	6	6	6

Data at the following conditions:

- ❶ Air: 27°C D.B.; 19°C W.B. - Acqua: 7/12°C.
- ❷ Air: 20°C - Water: 45/40°C.
- ❸ Air: 20°C - Water: 50°C, flow rate as in cooling.
- ❹ Air: 20°C - Water: 70/60°C.
- ❺ Air: 20°C - Water: 65/55°C.
- ❻ For room volume equal to 100 m³ and reverberation time = 0.5 sec.
- E Eurovent certificated performance.

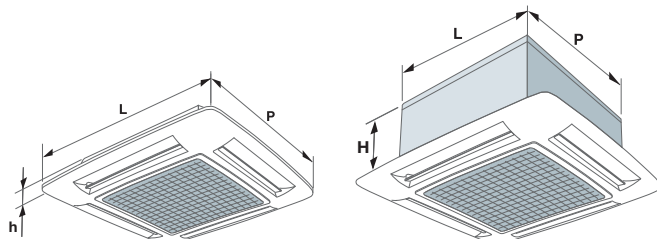

Fan coils

VTNC

Cooling capacity: 2.9÷7.8 kW - Heating capacity: 3.7÷9.4 kW



- **Cassette for 2-pipes-systems**
- **Adjustable movable fins**
- **Remote control (as per standard)**
- **Centralised control panel**

Cassette-type fan coil units

Construction features

- Fan coils: cassette-type for installation in false ceilings, with air return and flow directly into the room.
- Finned coil heat exchanger.
- 3 speed fan.
- Structure: load-bearing, in galvanised sheet steel, complete with condensate drain pump (up to 200 mm above the unit) and auxiliary condensation drain pan.
- Damping panel: in ABS polymer (RAL9010) with motorised flow fins adjustable in various positions, return grille and regenerable filter.
- Remote control: supplied as standard.

Versions

VTNC - Cassette for 2-pipe-systems

Separately supplied accessories

- 3-way ON/OFF electrovalve.
- 2-way ON/OFF electrovalve.
- Delivery nozzle lock.

STANDARD Controls

For wall mounting installation

- Electronic control panel for wall mounting.
- Centralised control panel for up to 64 units via serial connection, with daily and weekly time band management.
- Serial interface for connection with the control panel (proprietary protocol).

Key: → Supplied loose



Centralised control panel with daily/weekly time bands management.





VTNC			26	36	46	60	85
❶ Total cooling capacity	MAX	kW	2,91	3,59	4,37	5,8	7,83
	MED	kW	2,54	3,05	3,5	4,86	6,94
	MIN	kW	2,17	2,69	2,96	4,04	6,04
❶ Total cooling capacity [EN1397]	MAX	kW E	2,86	3,52	4,28	5,64	7,66
	MED	kW E	2,5	3	3,45	4,76	6,8
	MIN	kW E	2,14	2,65	2,92	3,95	5,92
❷ Heating capacity (45°C) [EN1397]	MAX	kW E	3,1	4,25	4,48	5,81	7,92
	MED	kW E	2,71	3,61	3,55	4,21	7,02
	MIN	kW E	2,37	3,21	3,03	3,23	6,63
❸ Heating capacity (50°C)	MAX	kW	3,65	4,95	5,31	6,89	9,42
	MED	kW	3,2	4,2	4,25	5,21	8,37
	MIN	kW	2,8	3,73	3,62	4,1	7,77
❹ Heating capacity (70°C) [EN1397]	MAX	kW	6,2	8,52	9,09	11,82	16,21
	MED	kW	5,46	7,31	7,42	8,92	14,59
	MIN	kW	4,84	6,56	6,34	6,93	13,8
Air flow speed	MAX	m³/h	560	690	840	1024	1460
	MED	m³/h	490	540	570	733	1228
	MIN	m³/h	380	440	470	640	1041
Sound power	MAX	dB(A) E	54	59	63	56	64
	MED	dB(A) E	47	52	56	51	58
	MIN	dB(A) E	41	46	48	45	56
❺ Sp. sound pressure	MAX	dB(A)	45	50	54	47	55
	MED	dB(A)	38	43	47	42	49
	MIN	dB(A)	32	37	39	36	47
Absorbed power	MAX	W E	50	70	90	156	170
	MED	W E	40	50	50	105	140
	MIN	W E	30	40	40	92	120
Electrical supply	V-ph-Hz		230-1-50	230-1-50	230-1-50	230-1-50	230-1-50
DIMENSIONS AND WEIGHTS			26	36	46	60	85
W2/H1/H2/D2 - Width 2/Height 1-2/Depth 2	mm		575/265/285/575	575/265/285/575	575/265/285/575	840/230/245/840	840/300/315/840
L/h1/h2/P - Width/Height/Depth	mm		647/50/30/647	647/50/30/647	647/50/30/647	950/50/35/950	950/50/35/951
Weight	kg		18	18	18	29	35
Ceiling panelling weight	kg		3	3	3	6	6

Data at the following conditions:

- ❶ Air: 27°C D.B.; 19°C W.B. - Acqua: 7/12°C.
 - ❷ Air: 20°C - Water: 45/40°C.
 - ❸ Air: 20°C - Water: 50°C, flow rate as in cooling.
 - ❹ Air: 20°C - Water: 70/60°C.
 - ❺ For room volume equal to 100 m³ and reverberation time = 0.5 sec.
- E Eurovent certificated performance.

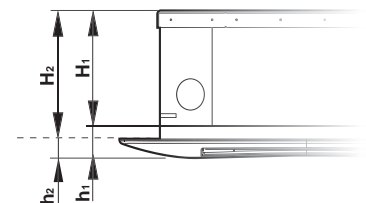
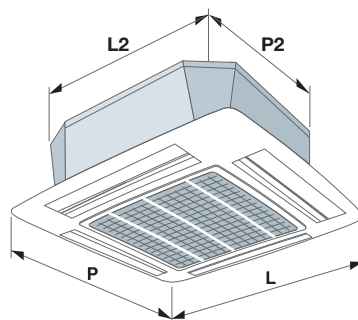





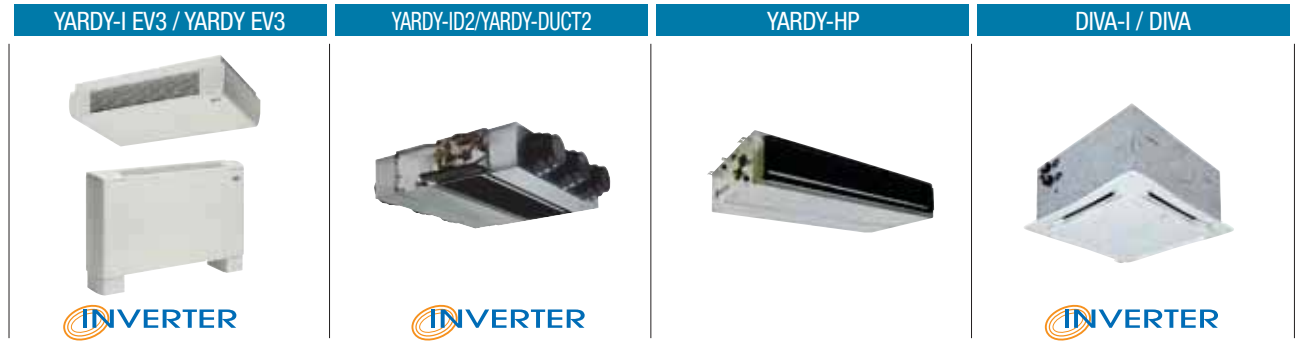



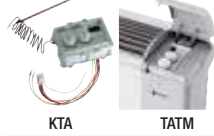

CONTROLS for fan coil units

COMPATIBLE FAN COIL CONVECTORS:



STANDARD CONTROLS

INSTALLATION:		3-speed ON/OFF switch	0-10 Vdc Minimum fan analogue	Room thermostat	Thermostat output	Air sensor with remote control option	Summer/winter switch	3-way ON/OFF valve control	2-way ON/OFF valve control	Electric heater control	Continuous ventilation/thermostat	2-pipe systems	4-pipe systems	Weekly time bands	Control interface for 4 fan coil units	Serial interface	
STANDARD FAN COIL	 → KC - ❖ C on board	◆															
	 → KTA - ❖ TATM on board	◆		◆	◆		◆										
	 → KCV2 receiver	◆				◆		◆								◆	
	 → KTCV2 wall mounted	◆			◆	ACCESSORY	◆	◆	◆	◆	◆	◆	◆	◆	◆	◆	◆
	 → KTCV2 wall mounted	◆			◆	ACCESSORY	◆	◆	◆	◆	◆	◆	◆	◆	◆	◆	◆
	 → KTCVA wall mounted	◆			◆		◆	◆	◆	◆	◆	◆	◆	◆	◆	◆	◆
	 → KTCVA wall mounted	◆			◆		◆	◆	◆	◆	◆	◆	◆	◆	◆	◆	◆
	 → KTCVA wall mounted	◆			◆		◆	◆	◆	◆	◆	◆	◆	◆	◆	◆	◆
	 → KTCVA wall mounted	◆			◆		◆	◆	◆	◆	◆	◆	◆	◆	◆	◆	◆
	 → KTCVR wall mounted	◆	AUTOMATIC SPEED / MINIMUM SPEED		REGULATION ±6°C	◆	◆	◆	◆	◆	◆	◆	◆	◆	◆	◆	◆
 → KTCVR wall mounted	◆	AUTOMATIC SPEED / MINIMUM SPEED		REGULATION ±6°C	◆	◆	◆	◆	◆	◆	◆	◆	◆	◆	◆	◆	
INVERTER FAN COIL	→ KTVD semi-recessed in wall	◆		◆	TIMED (A)		AUTOMATIC (B)	◆	◆	◆	◆	◆	◆	◆	◆	◆	
	→ KTVDM semi-recessed in wall	◆		◆	TIMED (A)		AUTOMATIC (B)	◆	◆	◆	◆	◆	◆	◆	◆	◆	
	→ KTVDI semi-recessed in wall	◆	◆	◆	TIMED (A)		AUTOMATIC (B)	◆	◆	◆	◆	◆	◆	◆	◆	◆	
	→ KTVDIM semi-recessed in wall	◆	◆	◆	TIMED (A)		AUTOMATIC (B)	◆	◆	◆	◆	◆	◆	◆	◆	◆	

(A) Fan or minimum thermostat with KSO probe (accessory) start delay.
 (B) Manual summer/winter switch or by contact or automatic with KSO probe (accessory).
 ❖ Factory mounted → supplied loose

IDRHOSS CONTROLS

Additional components:

- (1) MVR (or KMVR) only if you wish to manage an ON-OFF valve.
- (2) MVR (or KMVR) mandatory for electrical resistance management (also manages any ON-OFF valve).
- (3) MVR (or KMVR) + STI (or KSTI) mandatory to manage the two ON-OFF valves and the temperature probe for the additional coil.
- (4) KRS485 mandatory for RS485 Modbus communication.
- (5) Infrared receivers for remote control:
 - KRIP - For wall mounting installation (only for YARDY type of fan coils).
 - KRI - For installation on DIVA type of cassettes with PLP ceiling panelling.
 - KRIM - For installation on DIVA type of cassettes with PLM ceiling panelling.
- (6) Included ON/OFF valve management.

USER PANEL					
	PCM	KPCM	KICM	KTCM + KRIP/KRI/KRIM	NONE
Installation on fancoil	◆				No user panel in case of slave fan coil
Assembly receiver		◆			
Assembly panel			◆		
Remote control + receiver				◆ (5)	
Regulation functions	◆	◆	◆	◆	
Comfort functions	◆	◆	◆	◆	
Master/Slave function	◆ (MASTER)	◆ (MASTER)	◆ (MASTER)	◆ (MASTER)	◆ (SLAVE)

CIRCUIT BOARD		STANDARD FAN COIL		2-pipe systems	2-pipe systems with electric heater	4-pipe systems	Serial interface	IDRHOSS CONTROLS	PCM	KPCM	KICM	KTCM + KRIP/KRI/KRIM	NONE
		Factory fitted	Provided separately	◆ (1)	◆ (2)	◆ (3)	◆ (4)		◆ (MASTER)	◆ (MASTER)	◆ (MASTER)	◆ (MASTER)	◆ (SLAVE)
INVERTER FAN COIL	Factory fitted	◆ (1)	◆ (2)	◆ (3)	◆ (4)	→	→	↓	CMS/PCM	CMS + KPCM	CMS + KICM	CMS + KTCM + (5)	CMS
	Provided separately	◆ (1)	◆ (2)	◆ (3)	◆ (4)	→	→	↓	KCMS/PCM	KCMS + KPCM	KCMS + KICM	KCMS + KTCM + (5)	KCMS
	Factory fitted	◆ (6)	◆ (6)		◆ (4)	→	→	↓	CMIPCM2	CMI2 + KPCM	CMI2 + KICM	CMI2 + KTCM + (5)	CMI2
	Provided separately	◆ (6)	◆ (6)		◆ (4)	→	→	↓	KCMIPCM2	KCMI2 + KPCM	KCMI2 + KICM	KCMI2 + KTCM + (5)	KCMI2
	Factory fitted			◆ (6)	◆ (4)	→	→	↓	CMIPCM4	CMI4 + KPCM	CMI4 + KICM	CMI4 + KTCM + (5)	CMI2
Provided separately			◆ (6)	◆ (4)	→	→	↓	KCMIPCM4	KCMI4 + KPCM	KCMI4 + KICM	KCMI4 + KTCM + (5)	KCMI4	

MASTER/SLAVE FUNCTION

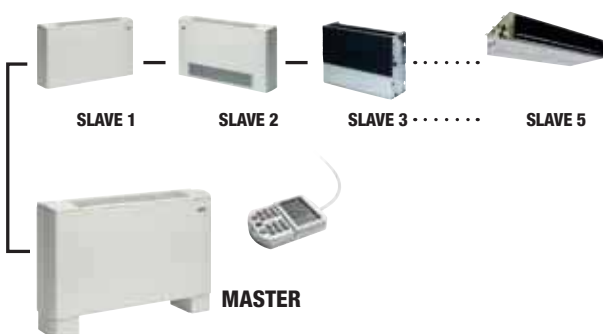

REGULATION FUNCTIONS

Automatic management - Cooling - Dehumidification - Manual/automatic Ventilation - Heating

COMFORT FUNCTIONS

Programmed activation/deactivation - Night-time air conditioning - Winter consent - Summer consent - Operation mode saving

ADVANCED FUNCTIONS

Economy - ON/OFF remote control - SUMMER/WINTER remote control - SECURITY control - PROBE IN/PROBE OUT - CONTINUOUS VENTILATION - COMFORT CONTROL - OCCUPANCY - ALARM - MASTER/SLAVE

MASTER/SLAVE FUNCTION - 6 units

Centralised management of up to 5 SLAVE units by means of one single MASTER unit without serial interface.

Terminal unit - UTNA Platinum 013÷120

Heat recovery unit - UTNR-A Platinum 040÷500

Heat recovery unit - UTNR-HE Platinum 040÷400

Heat recovery unit - UTNR-HP 035÷450

Heat recovery unit - VMC-E 025÷100



TERMINAL UNITS

Terminal unit

UTNA Platinum 013÷120

Cooling capacity: 6.4÷70 kW - Heating capacity: 4.9÷78 kW

INVERTER



ErP
READY
2018

APPLIES TO
EUROPEAN
DIRECTIVE
FOR ENERGY
RELATED
PRODUCTS

- Complying with ErP 2018 NRvU
- BRUSHLESS EC fan
- F7 high efficiency filters

Modular and ductable air handling terminal units

Construction features

- Terminal air handling unit: with modules for horizontal or vertical installation (013-050) with or without ducting.
- Structure with double wall sandwich type freestanding panelling, 30mm-thick with closed cell polyurethane foam insulation with high soundproofing and thermal insulation capacity.
- Routine machine maintenance from the bottom (for the horizontal version with installation in false ceiling or hanging from ceiling) or frontally (for the vertical version) with removable panels.
- BA Coil module (horizontal) / BAV coil module (vertical up to size 050) complete with: G4 standard filter, optional fine F7 filter. All filters are supplied complete with differential pressure switch to signal filter clogging condition in compliance with European regulation no. 1253/2014. Finned coil heat exchanger, in copper pipes and 2 rows of aluminium fins for heating or reheating only and 4-6 rows for cooling and/or heating with right or left connections to be selected on order. Condensate drain pan in aluminium both for horizontal BA4R and BA6R versions and vertical BAV4R and BAV6R versions.
- SV fan module complete with centrifugal plenum fan EC Brushless single suction directly coupled to electric motor. Static and dynamic balancing of the entire assembly, constructed in accordance with standard DIN ISO 1940. Degree of balancing G6.3. Standard control of the rotation speed via special 0-10V analogue input. Electrical connection panel fitted as standard complete with disconnect switch, protection fuses and connecting terminal block.

Accessory modules

- PMA - Intake/outlet plenum with pre-cut side outlets.
- SIL - Plenum with absorbent cartridge silencer to be placed on supply or intake.
- MUV-PRV - Plenum with steam humidifier and external electric generator.
- BE - Additional electrical coil for channel connection.

Factory mounted accessories

- SG - Optional drop separator at low load losses in polypropylene.
- TAG - Optional antifreeze thermostat.

Separately supplied accessories

- KSG - Drop separator at low load losses in polypropylene (only for BA).
- KTAG - Antifreeze thermostat (only for BA).
- KSER - Kit in combination with PMA consisting of: damper with aluminium blades and frame, fitted with seal gasket, certified class 2 according to En 1751 for fresh air (max 30%) or recirculated air and a fastening panel to PMA module. The damper is sized for treating up to 100% of the UTNA air capacity and may be positioned at the front, top or bottom of the PMA.
- KMS - Manual control for KSER damper.
- KB2R - Separately supplied additional reheat coil.





UTNAP MODEL			013	025	035	050	070	090	120	
②	Coil thermal power Only hot	BA 2R/BAV 2R	kW	4,9	8,4	11,7	16,8	25,1	32,8	39,1
①	Cooling capacity	BA/BAV 4R	kW	6,4	11,1	14,6	21,3	31,9	45,2	53,6
②	Heating capacity	BA/BAV 4R	kW	7,6	13,6	18,4	26,5	39,7	52,3	64,4
①	Cooling capacity	BA/BAV 6R	kW	8,1	14,9	20,2	27,5	41,2	56,8	68,9
②	Heating capacity	BA/BAV 6R	kW	9,1	16,6	22,8	32,2	48,3	62,1	78,2
③	Heater power	230V-1ph-50Hz	kW	3	-	-	-	-	-	-
	electrical BE	400V-3ph-50Hz	kW	-	6	9	13	17	24	24
④	Air flow rate	NOM	m³/h	1300	2500	3500	5000	7500	9000	12000
		MIN	m³/h	800	1100	1500	2100	3100	5000	5000
		MAX	m³/h	2100	3700	4800	6700	10500	14400	15500
④	Useful static head.	NOM	Pa	300	300	300	300	300	300	300
⑤	Irradiated sound power		dB(A)	47	50	54	54	56	55	59
⑤	Intake sound power		dB(A)	64	65	69	68	71	70	74
⑤	Delivery sound power		dB(A)	70	71	75	75	78	77	80
④	SFP Int (Erp 2018<230)		W/m³/s	80	121	137	128	143	101	146
	Filtration degree EN779		G4/F7	G4/F7	G4/F7	G4/F7	G4/F7	G4/F7	G4/F7	G4/F7
	PRV Maximum steam production		Kg/h	3	5	5	8	10	15	18
	Electrical supply	V-ph-Hz		230-1-50	230-1-50	230-1-50	230-1-50	400-3-50	400-3-50	400-3-50
DIMENSIONS AND WEIGHTS			013	025	035	050	070	090	120	
	L - Width	mm	945	1245	1545	1645	1645	2045	2045	
	H - Height	mm	387	387	387	504	687	837	837	
	PMA -SIL-MUV-SV- Depth	mm	480	480	480	596	780	931	931	
	BA - Depth	mm	750	750	750	750	750	750	750	
	BAV - Height	mm	812	812	862	962	-	-	-	
⑥	UTNA Weight	kg	53	60	67	88	94	132	142	

Data at the following conditions:

- ① Air T in 26°C BS; 18.6°C BU,(50% U.R.); water T in 7°C with Δt 5°C; nominal air flow.
- ② Air T in 20°C BS; 13.7°C BU,(50% U.R.); water T in 40°C with Δt 5°C; nominal air flow.
- ③ Air T in 20°C BS; 13.7°C BU,(50% U.R.); nominal air flow.
- ④ Air T in 20°C BS; 13.7°C BU,(50% U.R.); nominal air flow; 4-row coil BA/BAV 4R; clean type F7 filter.
- ⑤ Of SV only with work point at nominal air flow; and total head calculated in configuration: 4-row coil BA/BAV 4R; clean type F7 filter;300 Pa static useful. In accordance with EN ISO 11546-2.
- ⑥ SV. Weight

Controls

- KPTZ - Rotating potentiometer for wall installation, for manual fan speed control. The speed of supply and return fans is calibrated with a single potentiometer.
- KTVDIM - Electronic control panel with display, for semi-recessed wall installation, including ON/OFF button, MODE, 3 Speeds+AUTO, SETPOINT change; auxiliary contacts to control ON/OFF valve in 2-pipe and 4-pipe systems; summer/winter switchover; manual/automatic/ from contact; continuous/thermostat ventilation; configurable digital inputs (SCR, ECO, SIC, ALARM), weekly time bands management., complete with RS485 resident serial interface (Modbus RTU protocol).
- KRCA1 - Electronic control panel with display, for semi-recessed wall installation, including ON/OFF button, MODE, 2 Speeds, SETPOINT change; summer/winter switchover from button or remote digital input; continuous ventilation, weekly time bands management room probe; 3 analogue outputs to control modulating fan,

1 or 2 modulating valves in 2-pipe or 4-pipe systems, modulating damper; 1 auxiliary contact to control on/off electric heater (1 stage) in 2-pipe systems + electrical heater; 2 configurable digital inputs and 2 configurable analogue inputs. Complete with RS485 resident serial interface (Modbus RTU protocol).

Terminal unit

UTNA Platinum 013÷120

Cooling capacity: 6.4÷70 kW - Heating capacity: 4.9÷78 kW



Full Control Checks

- KRFCFS - Electrical panel complete with: DDC programmable microprocessor regulator. BMS interfacing Integrated as standard with Modbus RTU protocol, main disconnecting switch, relay to control various users, terminal blocks for quick connection of all machine components, auxiliary circuit supply with suitable transformer 230/12-24V.

USER PANELS (for KRFCFS)

- KHMIG - Interface terminal with black monochrome graphic display with LED backlighting.
- KHMIR - Interface terminal complete with integrated room temperature probe with black monochrome graphic display with LED backlighting.
- KTOUCH - Black and white touch screen control panel.
- KCOLOR - Colour touch screen control panel.
- KCVW - White decorative plate for control panel.
- KCB - Black decorative plate for control panel.
- KWMS - Wall mounting installation support for control panel.

Valves and actuators

- KV3V - PN40 Mixer/diverter 3-way regulation ball valves, female threaded hydraulic connections.
- KV2V - PN40 2-way regulation ball valves, female threaded hydraulic connections.
- KVMM - Actuator for ball regulation valves with modulating control 0/10 Vdc 24 Vac power supply.
- KVOM - Actuator for On/Off 230V valves.
- KDMA-S - Actuator for modulating damper 0-10V 24V with spring return.
- KDMA - Actuator for modulating damper 0-10V 24V without spring return.
- KDOA - Actuator for ON/OFF damper with spring return.

All the probes, actuators and valves you can find in the Full Control section are also available.

Full Control regulation

The Full Control kit allows integrated management of all the functions in the UTNAP, guaranteeing total control of room comfort in a simple and complete manner:

- **Simple installation: all components are designed for on site maximum simplicity and flexibility of installation and supplied separately to not hinder handling and the installation of the units in a false ceiling and in confined spaces. The electrical panel can also be installed remotely. Pre-assembled and pre-wired at the factory on request.**
- **Easy to use: intuitive and user friendly functions and menus.**
- **Weekly time schedule.**
- **Easy start-up: pre-calibrated regulators, pre-set and tested at the factory, specifically developed to manage all functions of the chosen configuration, avoiding any complication.**
- **Easily and immediately interfaced: controller comes standard with a USB port, RS 485 for dialogue via Modbus RTU and Canbus port to develop local networks.**

The following functions are present according to the selected machine composition:

- S.Q.R. - Duct or ambient air quality sensor to manage the fan speed or automatic modulation of the dampers.
- S.C.R. - Combined temperature and humidity return air or environment probe to manage air units with humidification and/or dehumidification functions.
- T.R. - Air return temperature probe.
- S.EX. - Shut-off damper.
- F.P.S. - Standard pleated filter.
- DP - Differential clogging filters pressure switch.
- BA - Hot/cold water coil.
- V.R.CF. - Hot-cold coil adjustment valve.
- T.A.G. - Antifreeze thermostat.
- SV EC - Brushless EC ventilated section.
- SV - 3-speed ventilated section.
- B.E. - Electrical coil.
- PV - Steam producer.
- T.M. - Supply temperature probe.
- KRFCFS - Full Control power and regulation electrical panel.
- KHMIG - Control panel with graphic display.



UTNA SV EC

UTNA fan unit

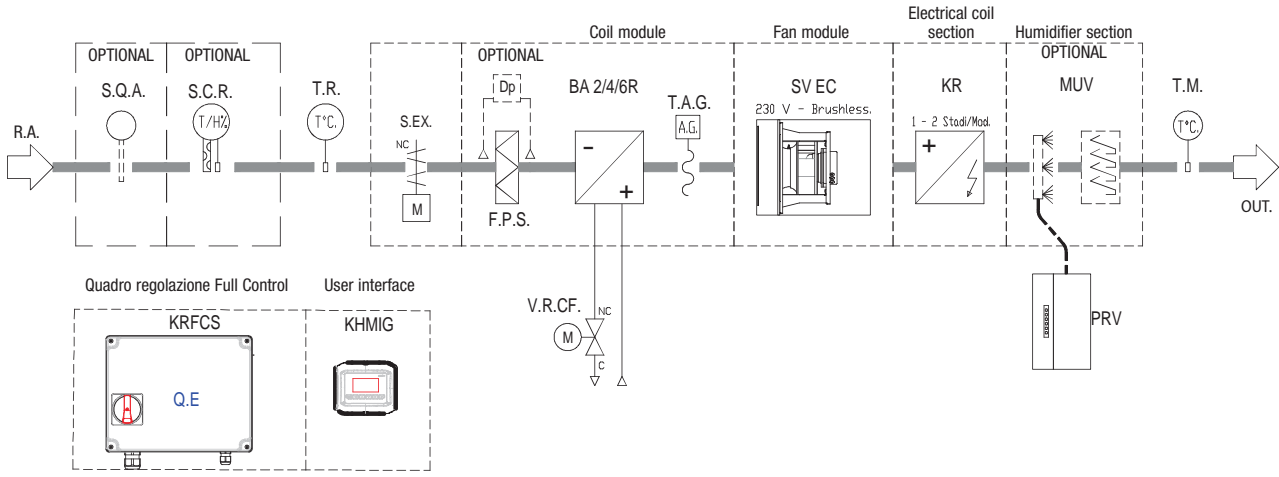

Heat recovery unit

UTNR-A Platinum 040÷500

Air flow rate: 400÷4,050 m³/h

INVERTER

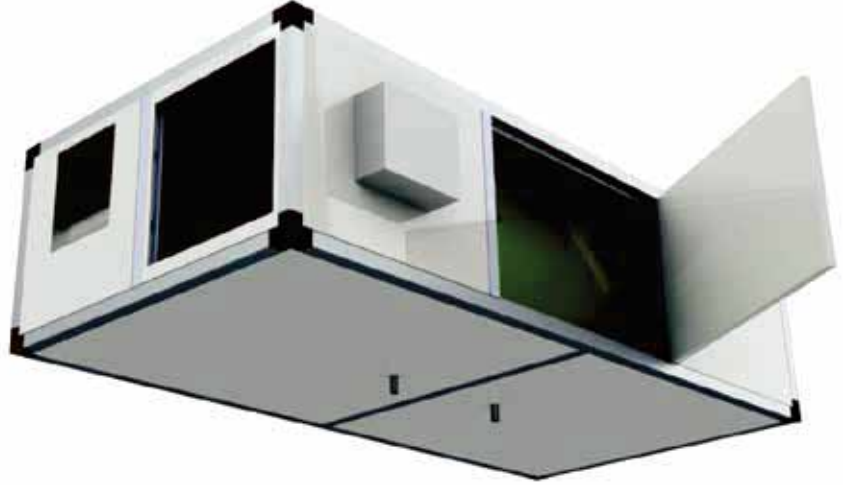

- Complying with ErP 2018 NRVU
- Eurovent certified very high efficiency heat recovery
- Multi-speed fans or Brushless EC
- F7 and M5 high efficiency filters
- Double-walled sandwich with high insulating power
- Full control kit

Fresh air terminal unit with opposing counterflow static heat recovery.

Construction features

- Recovery unit: with very high static type efficiency with counterflow aluminium plates with a close pitch. Extraction of the lateral exchange pack (except for size 40 with extraction from below).
- Fans: fresh air inlet and double intake centrifugal expulsion type with a continuously adjustable directly coupled electric motor; alternatively, Brushless EC high efficiency electric motors. Fan unit installed on anti-vibration mountings to prevent vibrations being transmitted to the structure.
- Structure: frame made with extruded aluminium profile with preloaded nylon joints. Sandwich damping panels, 20 mm thick, made internally with galvanised sheet metal and pre-painted externally with thermal and acoustic insulation in injected polyurethane with density 45 kg/m³ at very high heat and sound insulation power.
- Filtering section: filtration sections made of compact cell filters with a polypropylene mean at low pressure drop, removable from the side, in F7 efficiency class in the renewal flow and M5 in the ejection flow.
- Condensation drain pan made of galvanised sheet steel with condensation drain connection from the bottom.
- Integrated free cooling or thawing bypass system. The presence of a motorised damper at the side of the heat recovery can lead to a bypass system to control the free cooling or defrosting according to the temperature and humidity requirements or issues.

Versions

- UTNR-A/O PLATINUM - Recovery unit with opposing flow heat exchanger, installed horizontally and with standard multi-speed fans
- UTNRE-A/O PLATINUM - Recovery unit with opposing flow heat exchanger, installed horizontally and with Brushless EC fans that can reduce the consumed power for ventilation at equal performance.

Available orientation

- O1 - Right-hand connections
 - O2 - Left connections side
- The selected orientation must be indicated for the job order to be fulfilled.

Installation

- EXT- Outdoor installation including rain cover, 80mm high base and an outdoor electrical box

Factory fitted accessories

- BER - Reheating electrical heater installed inside, complete with filament-type safety thermostats and control relays to contain pressure drops. 230/1/50 single-phase electrical supply for models 040. 400/3/50 three-phase for models 075÷500.
- BA - Post-heating internal hot water coil.
- BAATG - Antifreeze thermostat installed downstream of the water reheating coil.
- ERF7M5PF - Differential pressure switch for dirty filters installed on standard filters (F7 outdoor air and M5 inlet).
- ERF7 - Efficiency recovery filter F7
- ERF7PF - Differential pressure switch for dirty filters installed on F7 outdoor air and F7 inlet filters.

Separately supplied accessories

- KSBFR - Section containing hot/cold water coil to reheat or recool, placed outside the machine in front of the inlet. Includes stainless steel condensation drain pan with drain connection from the bottom.
- KSBFR + ATG - Hot/cold water coil section with mounted antifreeze thermostat.
- KSRE - Regulation damper set for servo-control, consisting of a galvanised sheet steel frame with adjustable fins.
- KSSC - Duct silencer with a rectangular base made of glass wool covered with a protective film of glass fibre and micro-stretched sheet metal.
- KRMS - Sections with 3 dampers for air mixing and recirculating (only for the horizontal installation).
- KSPC - Panel with round fittings.



UTNR-A PLATINUM MODEL		40	75	100	150	200	320	400	500
Type of Unit		Non-residential- Bidirectional							
Outdoor air filters		F7							
Return air filters		M5							
Bypass		Motorisable lateral bypass damper							
TECHNICAL DATA									
Nominal air flow rate	m ³ /h	400	750	1000	1600	2050	3150	3700	4700
STANDARD FANS									
① Nominal available static pressure	Pa	100	100	100	100	100	100	100	n.d.
② Specific fan power (SFP)	W/(m ³ /s)	1286	921	1107	926	854	1143	1175	n.d.
③ Sound pressure level	dB(A)	59	60	63	63	63	69	69	n.d.
Speed N°/Type of Adjustment		1	3	3	3	3	3	2	n.d.
Electrical supply	V-ph-Hz	230-1-50	230-1-50	230-1-50	230-1-50	230-1-50	230-1-50	230-1-50	n.d.
BRUSHLESS EC FANS									
① Nominal available static pressure	Pa	100	100	100	100	100	100	100	100
① Max available static pressure	Pa	250	375	570	535	535	270	660	335
② Specific fan power (SFP)	W/(m ³ /s)	538	863	839	794	652	880	839	1226
③ Sound pressure level	dB(A)	60	61	62	64	62	68	68	69
Speed N°/Type of Adjustment		0-10 V							
Electrical supply	V-ph-Hz	230-1-50	230-1-50	230-1-50	230-1-50	230-1-50	230-1-50	230-1-50	230-1-50
COUNTERFLOW HEAT RECOVERY									
④ Winter Efficiency	%	81,8	86,8	85,3	81,8	82,3	80,8	81	81,1
⑤ Summer Efficiency	%	76,5	80	77,9	75,4	76,5	75,5	76,3	76,2
⑥ Efficiency Regulation EC 1253/2014	%	77,2	83,4	81,5	77,4	77,8	73	73	73
DIMENSIONS AND WEIGHTS									
Length/Height/Depth UTNR-A PLATINUM	mm	1480/380/800	1940/480/990	1940/480/990	2200/550/1000	2200/550/1400	2500/680/1400	2500/680/1400	2500/680/1700
UTNR-A/P O weight	kg	90	140	150	170	200	210	240	270

Data at the following conditions:

- ① Values referred to the nominal air flow considering the pressure drops of the heat recovery and the F7 filter
- ② Values referred to the nominal air flow and Nominal available static pressure
- ③ Sound pressure level referring to 1 m from the machine inlet in free field
- ④ Outdoor air T: -5°C, 80% RH ; Ambient air T: 20°C, 50% RH.
- ⑤ Outdoor air T: 32°C, 50% RH ; Amb. air T: 26°C, 50% RH.
- ⑥ Dry nominal conditions, measured according to En 308 in balanced flows. Outdoor air 5°C D.B.; Ambient air 25°C D.B.

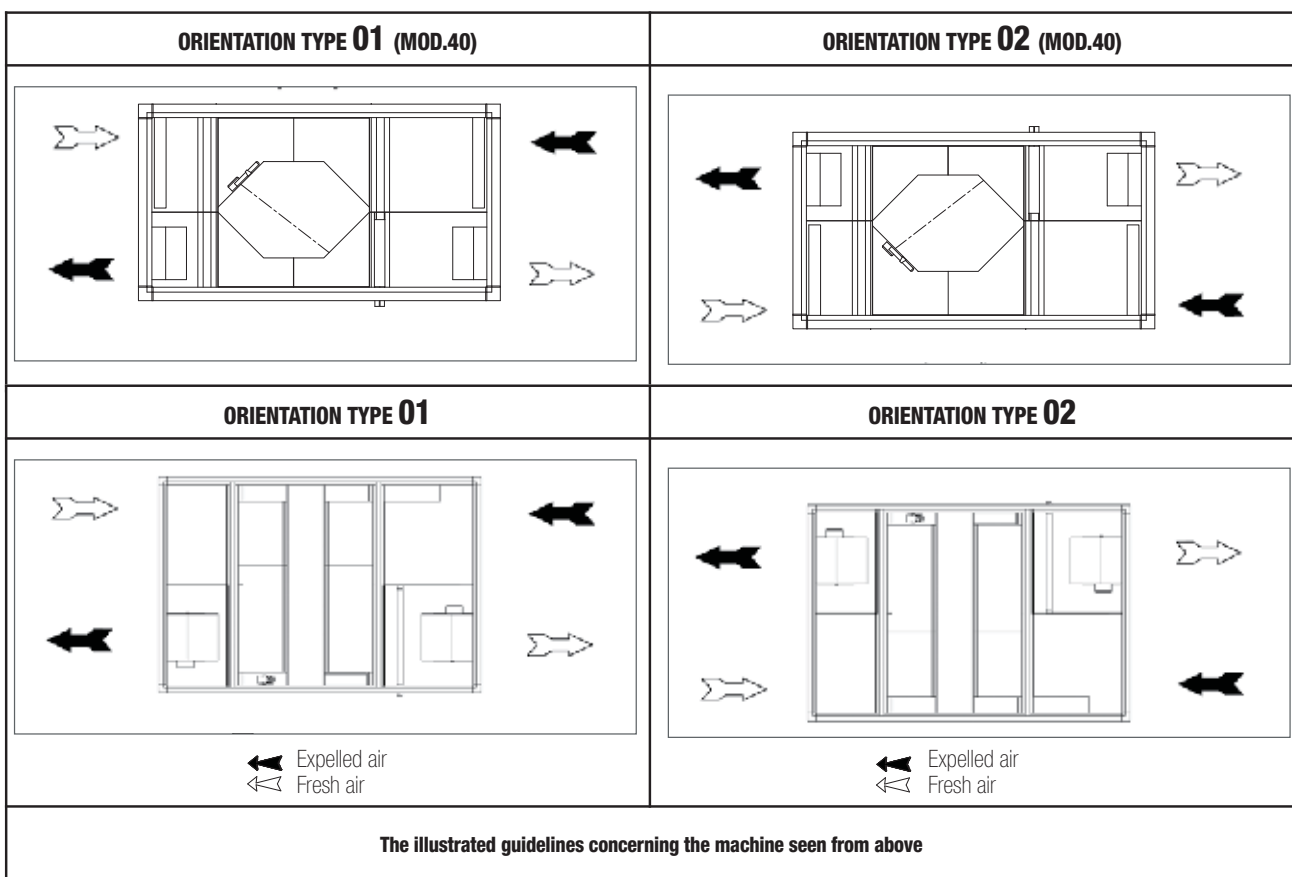

Heat recovery unit

UTNR-A Platinum 040÷500

Air flow rate: 400÷4,050 m³/h



Controls

- KVMM 3 (only for 040 models) - Electronic speed regulator suitable for wall mounting installation, which allows the fan with single-phase motor to be adjusted: ON/OFF switch, handle for continuous speed adjustment (only for the standard fan version).
- KCV2 - Speed selector for wall mounting installation, allows the 3 speeds to be switched (excluding model 40): Off/heating/cooling switch; 3-speed switch; 230V power supply.
- PCU-KPCUE - Control panel for wall mounting installation, allows the winter/summer environment temperature to be controlled, gives consent to activate or exclude the water coil or the electrical resistance. Selects the operating speed of the fan between minimum, medium, maximum (excluding model 40 for which the speed is unique) or by means of 0/10 V regulation (KPCUE for EC fans) and controls the free-cooling function.
- KPTZ - Rotating potentiometer for wall mounting installation, dedicated to manual fan speed control. The speed of delivery and return fans is calibrated with a single potentiometer (only for the EC Brushless fan version).



PCU Panel

•
KPCUE Panel



Full Controls

- KRFCs - Electrical panel complete with: DDC programmable microprocessor regulator. BMS interfacing Integrated as standard with Modbus RTU protocol, main disconnecting switch, relay to control various users, terminal blocks for quick connection of all machine components, auxiliary circuit supply with suitable transformer 230/12-24V.

USER PANELS (for KRFCs)

- KHMIG - Interface terminal with black monochrome graphic display with LED backlighting.
- KHMIR - Interface terminal complete with integrated room temperature probe with black monochrome graphic display with LED backlighting.
- KTOUCH - Black and white touch screen control panel.
- KCOLOR - Colour touch screen control panel.
- KCW - White decorative plate for control panel.
- KCB - Black decorative plate for control panel.
- KWMS - Wall mounting installation support for control panel.

Valves and actuators

- KV3V - PN40 Mixer/diverter 3-way regulation ball valves, female threaded hydraulic connections.
- KV2V - PN40 2-way regulation ball valves, female threaded hydraulic connections.
- KVMM - Actuator for ball regulation valves with modulating control 0/10 Vdc 24 Vac power supply.
- KVOM - Actuator for On/Off 230V valves.
- KDMA-S - Actuator for modulating damper 0-10V 24V with spring return.
- KDMA - Actuator for modulating damper 0-10V 24V without spring return.
- KDOA - Actuator for ON/OFF damper with spring return.

All the probes, actuators and valves you can find in the Full Control section are also available.



UTNRE-A Platinum

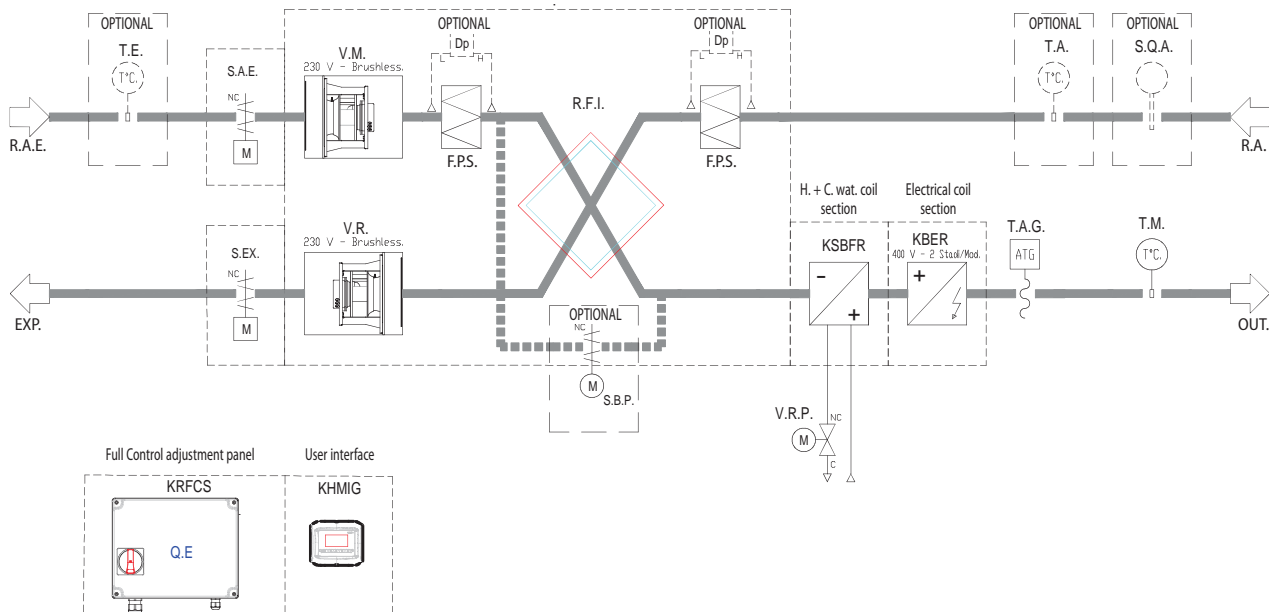

Full Control regulation

The Full Control kit allows integrated management of all the functions in the UTNRA-P, guaranteeing total control of room comfort in a simple and complete manner:

- **Simple installation: all components are designed for on site maximum simplicity and flexibility of installation and supplied separately to not hinder handling and the installation of the units in a false ceiling and in confined spaces. The electrical panel can also be installed remotely.**
Pre-assembled and pre-wired at the factory on request.
- **Easy to use: intuitive and user friendly functions and menus.**
- **Weekly time schedule.**
- **Easy start-up: pre-calibrated regulators, pre-set and tested at the factory, specifically developed to manage all functions of the chosen configuration, avoiding any complication.**
- **Easily and immediately interfaced: controller comes standard with a USB port, RS 485 for dialogue via Modbus RTU and Canbus port to develop local networks.**

The following are present according to the composition of the selected machine and accessories:

- T.E. - Outdoor air temperature probe.
- S.A.E. - Outdoor air damper.
- V.M. - Supply fan.
- F.P.S. - Standard pleated filter.
- Dp - Differential clogging filters pressure switch.
- KSBFR - Hot-cold additional coil module.
- V.R.P. - Mixed coil adjustment valve.
- BCR - Integrated hot water coil.
- V.R.C - Hot coil adjustment valve.
- BER - Integrated electrical coil.
- T.A.G. - Antifreeze thermostat.
- T.M. - Supply temperature probe.
- S.Q.A. - Environmental air quality probe.
- T.A. - Environmental air temperature probe.
- V.R. - Return fan.
- S.E.X. - Shut-off damper.
- KRFCS - Full Control power and regulation electrical panel.
- KHMIG - Control panel with graphic display.

Heat recovery unit

UTNR-HE Platinum 040÷400

Air flow rate: 310÷4,250 m³/h

INVERTER



- Complying with ErP 2018 NRVU
- Eurovent certified very high efficiency heat recovery
- Multi-speed fans or Brushless EC
- F7 and M5 high efficiency filters
- Double-walled sandwich with high insulating power
- Full control kit

Fresh air terminal unit with enthalpy rotary heat recovery.

Construction features

- Recovery unit: high yield rotary type made of aluminium with hygroscopic surface. Electric induction motor with belt and pulley transmission. Recovery unit-motor group easily removed from the side for periodic maintenance.
- Fans: fresh air inlet and double intake centrifugal expulsion type (for model 033 simple intake) with a directly coupled electric motor. Fan unit installed on anti-vibration mountings to prevent vibrations being transmitted.
- Structure: side panels that can be removed completely in Aluzink sheet metal.
- Filtering section: consisting of two class G4 filters (one on the fresh air intake and one on the ambient inlet), both can be removed from the side.
- Insulation: acoustic and thermal panel insulation with polyethylene/polyester having an average thickness of 20 mm.
- Terminal block: already present on the machine to facilitate the electrical connections, fan controls and rotary recovery.

Versions

- UTNR-HE/O PLATINUM - Recovery unit with rotary heat exchanger, installed horizontally and with standard multi-speed fans
- UTNRE-A/O PLATINUM - Recovery unit with rotary heat exchanger, installed horizontally and with Brushless EC fans that can reduce the consumed power for ventilation at equal performance.

Available orientation

- 01 - Right-hand connections
 - 02 - Left connections side
- The selected orientation must be indicated for the job order to be fulfilled.

Installation

- EXT- Outdoor installation

Factory fitted accessories

- ERF7M5PF - Differential pressure switch to indicate dirty filters installed on the standard filters (outdoor air F7 and return M5).
- ERF7-F7 efficiency return filter
- ERF7PF-Differential pressure switch to indicate dirty filters installed on the outdoor air F7 and return F7 filters.
- BP-Bypass control for free-cooling including:NC relay on board the panel (suitable for PCU and KPCUE) and 2 NTC probes on board the machine

Separately supplied accessories

- KBER - Reheating electrical resistance installed outside in a duct dedicated module, complete with filament-type safety thermostats and control relays to contain pressure drops.
230/1/50 single-phase electrical supply for model 040 and 075. 400/3/50 three-phase for 100 - 400 models.
- KSBFR - Section containing hot/cold water coil to reheat or recool, placed outside the machine in front of the inlet. Includes stainless steel condensation drain pan with drain connection from the bottom.
- KSBFR + ATG - Hot/cold water coil section with mounted antifreeze thermostat.
- KSRE - Regulation damper preset for servo-control, consisting of a galvanised sheet steel frame with adjustable fins.
- KSSC - Duct silencer with a rectangular base made of glass wool covered with a protective film of glass fibre and micro-stretched sheet metal.
- KRMS - Sections with 3 dampers for air mixing and recirculating (only for the horizontal installation).
- KSPC - Panel with round fittings.



UTNR-HE PLATINUM MODEL		40	75	100	150	200	320	400
Type of Unit		Non-residential- Bidirectional						
Outdoor air filters		F7						
Return air filters		M5						
Bypass		Motorisable lateral bypass damper						
TECHNICAL DATA								
Nominal air flow rate	m ³ /h	310	650	1150	1.900	2.320	3.600	4.250
STANDARD FANS								
① Nominal available static pressure	Pa	100	100	100	100	100	100	n.d.
② Specific fan power (SFP)	W/(m ³ /s)	1409	1443	1580	1036	806	1226	n.d.
③ Sound pressure level	dB(A)	59	60	63	63	63	69	n.d.
Speed N°/Type of Adjustment		1	3	3	3	3	3	n.d.
Electrical supply	V-ph-Hz	230-1-50	230-1-50	230-1-50	230-1-50	230-1-50	230-1-50	
BRUSHLESS EC FANS								
① Nominal available static pressure	Pa	100	100	100	100	100	100	100
① Max available static pressure	Pa	230	180	280	600	550	260	680
② Specific fan power (SFP)	W/(m ³ /s)	1045	1263	1102	842	617	869	1029
③ Sound pressure level	dB(A)	60	61	62	64	62	68	68
Speed N°/Type of Adjustment		0-10 V						
Electrical supply	V-ph-Hz	230-1-50	230-1-50	230-1-50	230-1-50	230-1-50	230-1-50	230-1-50
COUNTERFLOW HEAT RECOVERY								
④ Winter efficiency temp/enthalpy	%	84/81	74/71	73/71	73/70	76/73	73/71	73/71
⑤ Summer efficiency temp/enthalpy	%	84/78	74/69	74/69	73/69	76/72	74/69	74/69
⑥ Efficiency Regulation EC 1253/2014	%	84	74	73	73	76	73	73
DIMENSIONS AND WEIGHTS								
Length/Height/Depth UTNR-A PLATINUM	mm	1075/480/800	1075/480/800	1205/550/1000	1400/550/1000	1720/680/1290	1720/680/1290	1780/680/1400
UTNR-A/P O weight	kg	90	140	150	170	200	210	240

Data at the following conditions:

- ① Values referred to the nominal air flow considering the pressure drops of the heat recovery and the F7 filter
- ② Values referred to the nominal air flow and Nominal available static pressure
- ③ Sound pressure level referring to 1 m from the machine inlet in free field
- ④ Outdoor air T: -5°C, 80% RH ; Ambient air T: 20°C, 50% RH.
- ⑤ Outdoor air T: 32°C, 50% RH ; Amb. air T: 26°C, 50% RH.
- ⑥ Dry nominal conditions, measured according to En 308 in balanced flows. Outdoor air 5°C D.B.; Ambient air 25°C D.B.

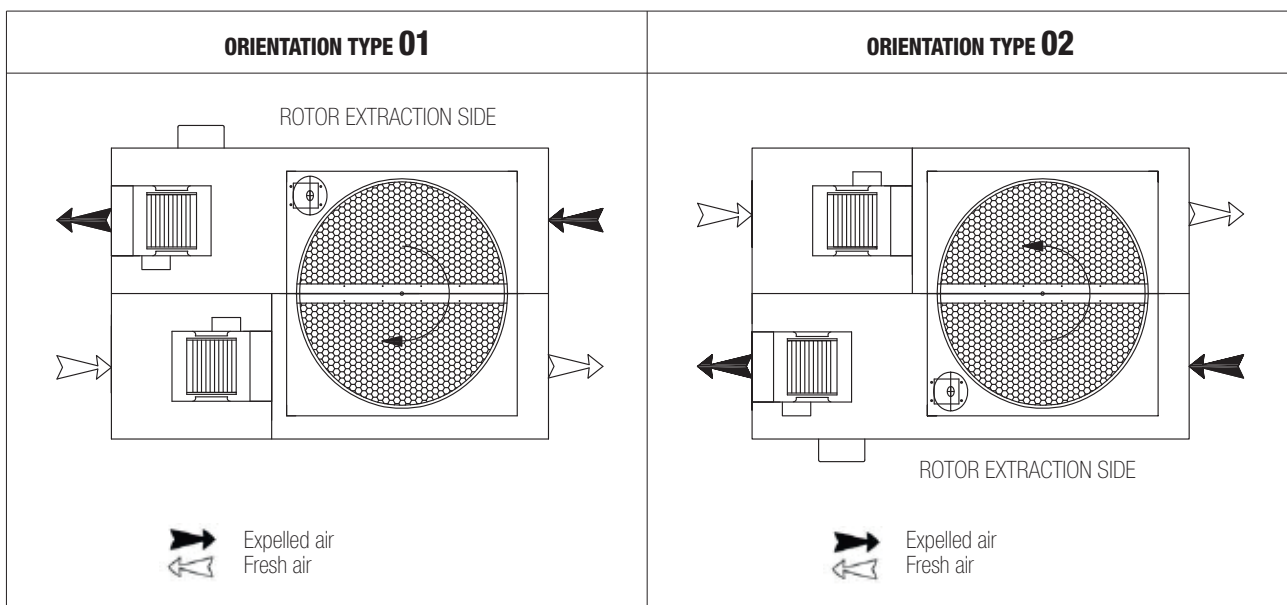

Heat recovery unit

UTNR-HE Platinum 040÷400

Air flow rate: 310÷4,250 m³/h



PCU Panel

KPCUE Panel



Controls

- KVVM 3 (only for 040 models) - Electronic speed regulator suitable for wall mounting installation, which allows the fan with single-phase motor to be adjusted: ON/OFF switch, handle for continuous speed adjustment (only for the standard fan version).
- KCV2-Speed selector for wall mounting installation, allows the 3 speeds to be switched (excluding model 40): Off/heating/cooling switch; 3-speed switch; 230V power supply.
- PCU-KPCUE, Control panel for wall mounting installation, allows the winter/summer environment temperature to be controlled, gives consent to activate or exclude the water coil or the electrical resistance. Selects the operating speed of the fan between minimum, medium, maximum (excluding model 40 for which the speed is unique) or by means of 0/10 V regulation (KPCUE for EC fans) and controls the free-cooling function.
- KPTZ - Rotating potentiometer for wall mounting installation, dedicated to manual fan speed control. The speed of delivery and return fans is calibrated with a single potentiometer (only for the EC Brushless fan version).

Full Controls

- KRFCs - Electrical panel complete with: DDC programmable microprocessor regulator. BMS interfacing Integrated as standard with Modbus RTU protocol, main disconnecting switch, relay to control various users, terminal blocks for quick connection of all machine components, auxiliary circuit supply with suitable transformer 230/12-24V.

Optional commissioning

User panels (for KRFCs)

- KHMIG - Interface terminal with black monochrome graphic display with LED backlighting.
- KHMIR - Interface terminal complete with integrated room temperature probe with black monochrome graphic display with LED backlighting.
- KTOUCH - Black and white touch screen control panel.
- KCOLOR - Colour touch screen control panel.
- KCW - White decorative plate for control panel.
- KCB - Black decorative plate for control panel.
- KWMS - Wall mounting installation support for control panel.

Valves and actuators

- KV3V - PN40 Mixer/diverter 3-way regulation ball valves, female threaded hydraulic connections.
- KV2V - PN40 2-way regulation ball valves, female threaded hydraulic connections.
- KVMM - Actuator for ball regulation valves with modulating control 0/10 Vdc 24 Vac power supply.
- KVOM - Actuator for On/Off 230V valves.
- KDMA-S - Actuator for modulating damper 0-10V 24V with spring return.
- KDMA - Actuator for modulating damper 0-10V 24V without spring return.
- KDOA - Actuator for ON/OFF damper with spring return.

All the probes, actuators and valves you can find in the Full Control section are also available.

Full Control regulation

The Full Control kit allows integrated management of all the functions in the UTNRHE, guaranteeing total control of room comfort in a simple and complete manner:

- **Simple installation: all components are designed for on site maximum simplicity and flexibility of installation and supplied separately to not hinder handling and the installation of the units in a false ceiling and in confined spaces. The electrical panel can also be installed remotely. Pre-assembled and pre-wired at the factory on request.**
- **Easy to use: intuitive and user friendly functions and menus.**
- **Weekly time schedule.**
- **Easy start-up: pre-calibrated regulators, pre-set and tested at the factory, specifically developed to manage all functions of the chosen configuration, avoiding any complication.**
- **Easily and immediately interfaced: controller comes standard with a USB port, RS 485 for dialogue via Modbus RTU and Canbus port to develop local networks.**

The following are present according to the composition of the selected machine and accessories:

- T.E. - Outdoor air temperature probe.
- S.A.E. - Outdoor air damper.
- V.M. - Supply fan.
- F.P.S. - Standard pleated filter.
- Dp - Differential clogging filters pressure switch.
- KSBFR - Hot-cold additional coil module.
- V.R.P. - Mixed coil adjustment valve.
- BCR - Integrated hot water coil.
- V.R.C - Hot coil adjustment valve.
- BER - Integrated electrical coil.
- T.A.G. - Antifreeze thermostat.
- T.M. - Supply air thermostat.
- S.Q.A. - Environmental air quality probe.
- T.A. - Air return or ambient temperature probe.
- V.R. - Return fan.
- S.EX. - Shut-off damper.
- KRFCs - Full Control power and regulation electrical panel.
- KHMIG - Control panel with graphic display.

UTNR-HE Platinum version E brushless

UTNRE-HE Platinum recovery unit

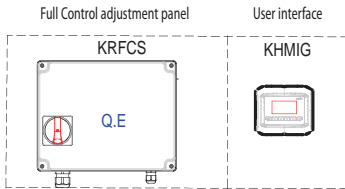
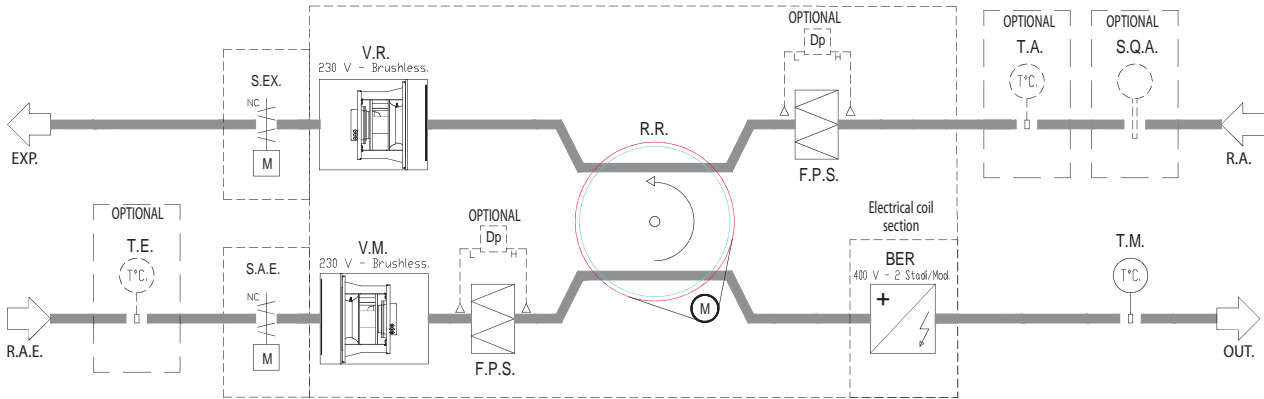

UTNR-HE Platinum

UTNRE-HE Platinum recovery unit

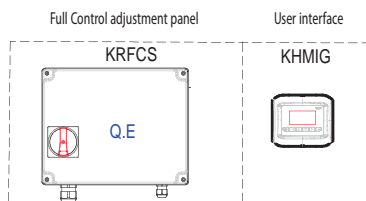
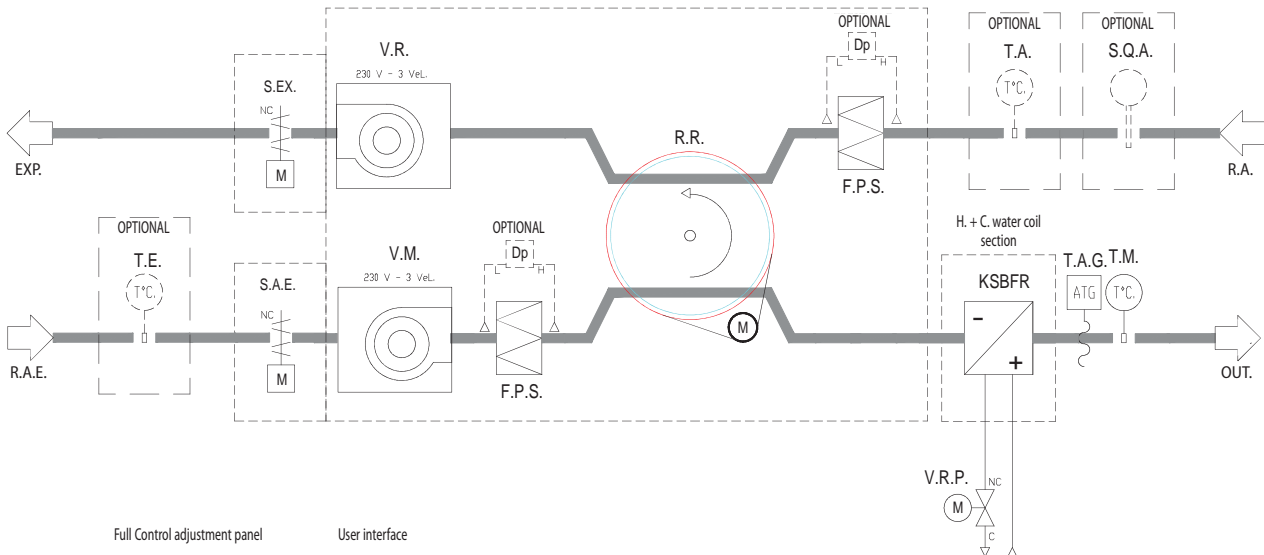

Controls

FULL CONTROL



The Full Control adjustment system aims to meet all the adjustment requirements of our units in the UTNA - UTVN - UTVR A/P and HE comfort range starting from the most basic up to fully-equipped units.

MAIN CONTROL LOGIC SETTINGS

Temperature adjustment at a supply fixed point (primary air)

The Tm fixed point probe controls the supply temperature using the modulating actuator of the control valve.

"Sliding" adjustment of the supply temperature according to the ambient set-point (all air)

The supply set-point is calibrated according to the difference between the room temperature and set-point, with the authority set. This function allows the performance of a control loop with a high degree of difficulty to be improved, thereby reducing the delay with which the ambient/return probe indicates the interference that occurs in the supply and is used as a base when the ambient temperature is to be set.

Result

The supply air temperature varies according to the difference between the actual ambient temperature and that prescribed.

Benefits for the end user

The ambient temperature control is faster and more accurate, and the gap on the ambient set-point is smaller than that achieved with separate ambient/return temperature control.

Antifreeze protection function

The TAG antifreeze thermostat protects the coil from frost (in case of intervention) when the outdoor air damper closes and the unit stops

Filter clogging monitoring

The cleanliness and healthiness of the filters is constantly monitored by the differential pressure switch as required by the relevant EU regulation

2-pipe systems

In case of the mixed coil, the season must be selected from the control panel or the remote selector.

The E/I selector also lets you exclude antifreeze protection while the coil is powered by cold water.

4-pipe systems

The hot and cold valve control is in automatic sequence, with central dead band to prevent instability.

Supply summer temperature compensation in relation to the outdoor one

Adjusting the ambient/return humidity

The humidity probe on the return controls the humidity. During winter, it modulates the delivery of the steam humidifier. During the summer period it acts on the actuator of the control valve of the cold coil, thereby modulating the performance.

Temperature free-cooling

This type of function is ONLY possible if you have selected a unit with heat recovery and it is set to achieve maximum savings.

Energy will be saved in systems with internal foreign heat production in cooling mode since the typical outdoor temperatures of the winter or intermediate seasons (approx. 10 to 20°C), the ambient temperature controller controls the outdoor air dampers and expulsion on opening and recirculation on closing, thereby eliminating the added heat with a corresponding percentage of outdoor air.

The function must be activated on start-up.

UNIT		UTNA/UTNV		UTNR A-P-HE		
FUNCTION		AP	TA	AP	TA	
CONFIGURATIONS / FUNCTIONS	2-pipe single coil (Hot, Cold, Mixed)	●	●	●	●	
	4-pipe second coil (Hot, Mixed)	●	●	●	●	
	Fan control 1, 2 or 3V	●	●	●	●	
	Fan control control (operated manually from the control panel or from the external input/potentiometer or according to the pressure/IAQ/Humidity probes)	●	●	●	●	
	On/off damper control (operated electro-mechanically when the machine is switched on and the optional antifreeze thermostat, in case of alarm)	●	●	●	●	
	Mixture chamber module damper control (potentiometer/from controller)	n/a	●	n/a	n/a	
	Separate control for double vent.	n/a	n/a	●	●	
	Recovery unit bypass command (for free-cooling control)	n/a	n/a	●	●	
	Recovery unit antifreeze control	n/a	n/a	●	●	
	On/off dehumidifier command	●	●	●	●	
	Modulating dehumidifier command	●	●	●	●	
	Coil on/off command Electric (ONLY 2-pipe versions alternative to the second hot coil for UTNA and UTNR)	●	●	●	●	
	Coil modul. command Electric (ONLY 2-pipe versions alternative to the second hot coil for UTNA and UTNR)	OPT	OPT	OPT	OPT	
	PROBES	Antifreeze Thermostat	●	●	●	●
Supply temperature probe		●	●	●	●	
Ambient/Return temperature probe and combined return/ambient temperature + humidity probe		●	●	●	●	
Ambient/Return Humidity Probe		●	●	●	●	
IAQ input probe* (Modulating damper control or fan speed)		●	●	●	●	
Channel const. pressure probe input (Speed modulation of the fans on VAV systems with separate zone dampers or pressurised control)**		●	●	●	●	
Outdoor air temperature probe outlet (for supply set-point compensation, recovery/free-cooling bypass)		●	●	●	●	
Dp filter pressure switch input		n/a	●	n/a	●	
Remote temperature recalibration potentiometer input and remote damper positioning		●	●	●	●	
Input Remote E/I selection input (ONLY 2 pipes)		●	●	●	●	
I/O OPT.	Remote On/Off input	●	●	●	●	
	Economy input (from external timer, micro window, badge reader, etc.)	●	●	●	●	
	Ext. alarm input (general alarm, fire protection etc) for emergency stop	●	●	●	●	
	Alarm repeat output (Relay)	n/a	n/a	n/a	n/a	
	Thawing input from heat pump	●	●	n/a	n/a	
	E/I switching output for heat pump	●	●	●	●	
	Pump control 1 (auxiliary, not power, for the pump or generator to service the coil/circuit 1)	●	●	●	●	
	Pump control 2 (auxiliary, not power, for the pump or generator to service the coil/circuit 2)	●	●	●	●	
	ADDITIONAL FUNCTIONS	Modbus serial communication	●	●	●	●
		Weekly time schedule	●	●	●	●
Holiday schedule		●	●	●	●	

** only with the Brushless EC fan
n/a: not available
OPT: option

Controls

FULL CONTROL

Separately supplied accessories

- KSEZM - Single-phase main disconnecting switch on the front of the electrical panel interrupts the power supply before allowing the door to be opened. It can be blocked with a padlock.
Separately supplied accessories
- KSEZT - Three-phase main disconnecting switch on the front of the electrical panel interrupts the power supply before allowing the door to be opened. It can be blocked with a padlock.
- KPD - Differential air pressure switch (20-300Pa) to indicate the alarm when the point of intervention set to detect a dirty filter or air flow is reached.
- KTAG - Antifreeze thermostat (with brackets).
- KPOTS - Remote potentiometer for damper calibration.
- KLS - Damper manual command lever

Probes

- KATS - Ambient air NTC temperature probe (in the diagrams: TA).
- KDTS - NTC temperature probe from the channel (in the diagrams: TM/TR/TX).
- KOTS - Outdoor air NTC temperature probe (in the diagrams: TE).
- KDHS - Active humidity probe from channel with 0/10Vdc signal (in the diagrams: TUR/TUM).
- KATHS - Ambient temperature/humidity probe (in the diagrams: TUA).
- KDTHS - Channel temperature/humidity probe (in the diagrams: UR/UM).
- KAVOCS - Ambient IAQ VOC probe (in the diagrams: IAQ).
- KDVOCS - Channel IAQ VOC probe (in the diagrams: IAQ).
- KAIAGS - Ambient IAQ VOC+CO2 probe.
- KDIAQS - Channel IAQ VOC/CO2 probe.
- KDAPS - Air pressure probe.

Mixing/diverter 3-way ball PN40 VALVE.

With body and shaft in brass and chrome plated brass ball. Sealed with an EPDM ring, female THREADED hydraulic connections

- KV3V15-x_x - 3-WAY threaded VALVE. DN15 kv from 1.6 to 6.3 depending on the sizes.
- KV3V20-6_3 - 3-WAY threaded VALVE DN20 kv 6.3.
- KV3V25-10 - 3-WAY threaded VALVE DN25 kv 10.
- KV3V20-6_3 - 3-WAY threaded VALVE DN32 kv 16.
- KV3V40-25 - 3-WAY threaded VALVE DN40 kv 25.
- KV3V50-xx - 3-WAY threaded VALVE DN50 kv 40 or 63 depending on the sizes.

Adjustment 2-way ball PN40 VALVES.

With body and shaft in brass and chrome plated brass ball. Sealed with an EPDM ring, female THREADED hydraulic connections.

- KV2V15-x_x - 2-WAY threaded VALVE. DN15 kv from 1.6 to 6.3 depending on the sizes.
- KV2V20-6_3 - 2-WAY threaded VALVE DN20 kv 6.3.
- KV2V25-10 - 2-WAY threaded VALVE DN25 kv 10.
- KV2V32-16 - 2-WAY threaded VALVE DN32 kv 16.
- KV2V40-25 - 2-WAY threaded VALVE DN40 kv 25.
- KV2V50-40 - 2-WAY threaded VALVE DN50 kv 40.

Actuators for regulation BALL valves with 0/10Vdc 24Vac power supply modulating control

- KVMM25 - ACTUATOR V.DN MAX25 24V 0-10Vdc.
- KVMM50 - ACTUATOR V.DN MAX50 24V 0-10Vdc.

On/Off valve actuators, 230V TO OPERATE WITH 2-position control FAN-COIL THERMOSTATS

- KVOM25 - ACTUATOR V. DN MAX 25 230V On/Off SPDT.
- KVOM25 - ACTUATOR V. DN MAX 25 230V On/Off SPRING RET. SPST.
- KVOM50 - ACTUATOR V. DN MAX 50 230V On/Off SPRING RET. SPST.

ACTUATORS FOR MODULATING DAMPERS 0-10V 24V

- KDMAxS - ROT. DAMP. ACTUATOR 2/7/18Nm modulating with 24V spring return
- KDMAx b - ROT. DAMP. ACTUATOR 5/10/15Nm modulating without 24V spring return

ACTUATORS FOR ON-OFF 24V DAMPERS

- KDOAxS - ROT. DAMP. ACTUATOR 2/7/18 Nm on/off with 24V spring return

BASIC CONTROLS

User panels

With these accessories you can easily manage all active control functions by means of symbols and clear icons and intuitive including: change the set-point, manage summer/winter seasonal switching, manage the ON/OFF power, manage the ventilation mode, display the temperature, humidity and all the values measured by the connected probes, set a weekly program schedule or a timer for prolonged absences (holiday mode), view alarms, reset alarms and manually position any motorised dampers in modulating control.

The features described above are common to all the following control panels. All Panel controls are used for box recessed installation (BTicino 506 type). You can customise the terminal to integrate it aesthetically in environments with the KCW or KCB plates according to the price list or the several Bticino series "Living" and "Light" plaques.

- KHMIG - Vgraph control panel. Interface terminal with black monochrome graphic display with LED backlighting.
- KHMIR - Control panel with ambient temperature probe (Vroom). In addition to the functions of the previous control panel implemented a temperature probe in the panel.
- KTOUCH - Black and white monochrome touch screen control panel 320x240 pixels.
- KCOLOR - Colour touch screen control panel 320x240 pixels.
- KCW - White decorative plate for control panel.
- KCB - Black decorative plate for control panel.
- KWMS - Wall mounting installation support for control panel.



KHMIG and KHMIR



KCOLOR



KCW

Electrical panel in a resin case, with IP55 protection, compliant with IEC EN 60204-1, complete with:

- DDC programmable microprocessor regulator that can manage up to 40 I/O with Rhoss software and configuration specifically designed to make sure the optimal automatic control of all functions can be managed on the machine, via continuous comparisons made between the set values and the temperature and humidity conditions detected by the sensors. The adjustment, optimised with proportional-type algorithms plus integral (PI), assures accurate and safe operation of the air handling unit. The regulator is equipped with a Real Time Clock to set the date, time and time program, with a backup battery to keep the saved data even in case of a prolonged power cut (up to 2 days). Interfaced with BMS Integrated as standard with Modbus RTU protocol.
- Main disconnecting switch.
- Fuse holder to protect single phase fan motors with power up to 1.6 kW with isolating function for phase and neutral on opening (*).
- Motor protection fuses for the motor of a rotary recovery, the 230/12V transformer and the 24V auxiliary circuit.
- Relay to control various utilities.
- Spring terminal blocks with removable connectors for quick connection of all components on the machine.
- Electrical supply 1F+N 230V 50Hz.
- Auxiliary power supply with a converter transformer 230/12-24V.
(* An external panel with specific protection and drive devices must be added required for higher power and three-phase loads .
- KRFCs - Full Control power and regulation electrical panel for UTNB-UTNA-UTNR-UTNV Single-phase Max Pow. 2x1.6 kW.



AMBIENT regulators for wall mounting with software application, display, ambient sensor, RS485 serial board and clock with control of up to 9 I/O.

- KRCA1 - Ambient regulator with integrated temperature probe to control the following functions:
 - 2 modulating coils, antifreeze, 1 modulating damper, 1 on/off resistance
 - modulating coils, antifreeze, 1 modulating fan, 1 on/off resistance
 - 2 modulating coils, antifreeze, 1 modulating resistance, 1 on/off fan
 - 2 modulating coils, antifreeze, 1 modulating fan, recovery bypass
- KRCA2 - Ambient regulator with integrated temperature probe to control the following functions:
 - 2 modulating coils, antifreeze, 1 on/off fan, 1 aux. on/off control
 - 2 modulating coils, antifreeze, 1 on/off fan, recovery bypass, 1 aux. on/off control
 - 2 modulating coils, antifreeze, 1 on/off resistance, recovery bypass, 1 aux. on/off control



- KDTR - Usable with all UTNA-V-R with 1 coil. Simple and reliable regulator to be installed in the delivery duct, in the same case which already holds the temperature probe and is designed to handle simple air handling units operating at a supply fixed point. Operating range 0-50°C:
- KPOTR - Remote potentiometer for damper recalibration (in combination with KDTR).

Heat recovery unit

UTNR-HP 035÷450

Air flow rate: 350÷4500 m³/h

 **INVERTER**



- Combined cross flow and active thermodynamic heat recovery
- Standard air filter with G4 efficiency
- Integrated electronics

Fresh air terminal units with two-stage heat recovery unit.

Construction features

- Recovery unit:
 - First stage of the crossed flow air-air static heat recovery with aluminium heat exchanger plates; lower condensation drain pan along the entire heat treatment area.
 - Second stage of the active thermodynamic heat recovery unit with heat pump cooling circuit (with R410A gas) consisting of hermetic compressor (rotary or scroll type depending on the unit size), evaporating and condensing coils with copper pipes and continuous aluminium fins, electronic expansion valve, liquid separator and receiver, 4-way valve for cycle inversion, high and low pressure switches, freon filter and liquid indicator.
- Fans: fresh air inlet and double intake centrifugal expulsion type with a directly coupled electric motor. Fan unit installed on anti-vibration mountings to prevent vibrations being transmitted.
- Structure and panels: frame made with extruded aluminium profile, Anticorodal 63 alloy, with preloaded nylon angular joints. Sandwich damping panels, 23 mm thick, made internally with galvanised sheet steel and externally with galvanised pre-painted sheet steel (RAL 9002), with thermal and acoustic insulation made of injected polyurethane, whose density is 45 kg/m³.
- Filtering section: consisting of two class G4 filters (one on the fresh air intake and one on the ambient inlet), both can be removed from the bottom and the side.
- Electrical panel: with integrated adjustment and power; NTC temperature probes on both the delivery and return air circuits; micro-processor electronic control for automatic room temperature management, winter/summer switch and defrosting cycles; remote control panel from up to 20 m from the unit, already equipped with Modbus RTU protocol for communication with the supervision system.

Versions

Available orientation:

- UTNR-HP 01, 02 – Heat recovery unit with crossed flow and active thermodynamic double heat exchanger with 01 or 02 orientation (right connection side) or 01s or 02s (left connection side).
The selected orientation must be indicated for the job order to be fulfilled.

Installation

- EXT - Protective canopy for external installation.

Factory fitted accessories

- BER - Filament type reheating electrical resistance installed internally, complete with safety thermostats and control relays. 230/1/50 single-phase for models 035÷150. 400/3/50 three-phase for models 230÷450.
- BEP - Filament type reheating electrical heater installed internally, complete with safety thermostats and control relays. 230/1/50 single-phase for models 035÷150. 400/3/50 three-phase for models 230÷450.
- PF - Differential pressure switch installed in the inlet filter to indicate a dirty filter.
- ATG - Antifreeze thermostat installed downstream of the water coil.
- EG4PF - G4 outdoor air filter with differential pressure switch.
- ERG4PF - G4 outdoor air filter and G4 return air with differential pressure switch.
- EF7 - F7 outdoor air filter.
- ERF7 - F7 outdoor and return air filter.
- EG7PF - F7 outdoor air filter with differential pressure switch.
- ERF7PF - F7 outdoor and return air filter with differential pressure switch.

Separately supplied accessories

- KSBFR - Section containing hot/cold water coil to reheat or recool, placed outside the machine in front of the inlet. Includes a stainless steel condensation drain pan with drain connection from the bottom.
- KSBFR + ATG - Hot/cold water coil section with mounted antifreeze thermostat.
- KV2V ON/OFF - 2 way valve kit with On/Off servo-control.
- KV3V ON/OFF - 3 way valve kit with On/Off servo-control.
- KSRE - Regulation damper set for servo-control, consisting of a galvanised sheet steel frame with adjustable fins.
- KSMR 230 - Damper actuator with spring return.
- KSSC - Duct silencer with wool baffles covered with glass fibre and micro-stretched sheet.

Controls supplied separately

- KPTZ - Potentiometer for Brushless EC fan control.





UTNR-HP MODEL		35	60	100	150	230	320	450
Nominal air flow rate	m ³ /h	350	600	1000	1500	2300	3200	4500
Delivery available static pressure	Pa	165	170	195	155	155	185	175
Available return static pressure	Pa	140	100	140	95	95	115	110
① Sound pressure level	db (A)	59/47/52	64/50/55	62/49/54	67/54/57	65/51/59	68/54/59	70/56/59
Delivery max available static pressure - Version E Brushless	Pa	270	285	295	290	365	265	270
Max. available return static pressure - Version E Brushless	Pa	245	215	240	230	305	195	205
FUNCTIONAL LIMITS		35	60	100	150	230	320	450
② Limit operating conditions	°C / %	MIN -10°C OUT & MIN 19°C 50% IN MAX 38°C 50% OUT & MAX 27°C IN						
Flow variation range	%	-7 ÷ +7						
ELECTRICAL DATA		35	60	100	150	230	320	450
Electrical supply	V/ph/Hz	230/1/50	230/1/50	230/1/50	230/1/50	400/3/50	400/3/50	400/3/50
Max. absorption	A	5,3	9,0	13,2	20,2	10,0	15,4	16,4
③ PERFORMANCE IN HEATING MODE		35	60	100	150	230	320	450
Static recovery efficiency	%	62	51	50	50	50	50	50
Active recovery	W	1740	2960	5010	7690	11090	16300	17300
Total power	W	3580	5790	9410	14390	21190	30260	36010
Treated air temperature	°C	24	23	22	22	22	22	18
④ overall COP	W/W	10,90	9,60	9,22	8,64	8,90	9,90	12,60
⑤ PERFORMANCE IN COOLING MODE		35	60	100	150	230	320	450
Static recovery efficiency	%	56	50	50	50	50	50	49
Active recovery	W	1810	2860	4890	7270	10580	15310	16990
Total power	W	2210	3450	5840	8720	12830	18390	21440
Treated air temperature	°C	19	20	20	20	20	20	21
④ overall EER	W/W	4,2	3,9	4,2	3,9	3,9	4,1	5,01

Data at the following conditions:

- ① Sound pressure level assessed at 1 m from; permanent ducted socket/intake socket/compressor compartment. Generally, the operating noise level differs from the indicated values depending on the operating conditions, reflected noise and peripheral noise.
- ② Referred to the nominal flow rate.
- ③ Outdoor air -5°C RH 80%; ambient air 20°C RH 50%.
- ④ Excluding ventilation power consumption.
- ⑤ Outdoor air 32°C RH 50%; ambient air 26°C RH 50%.

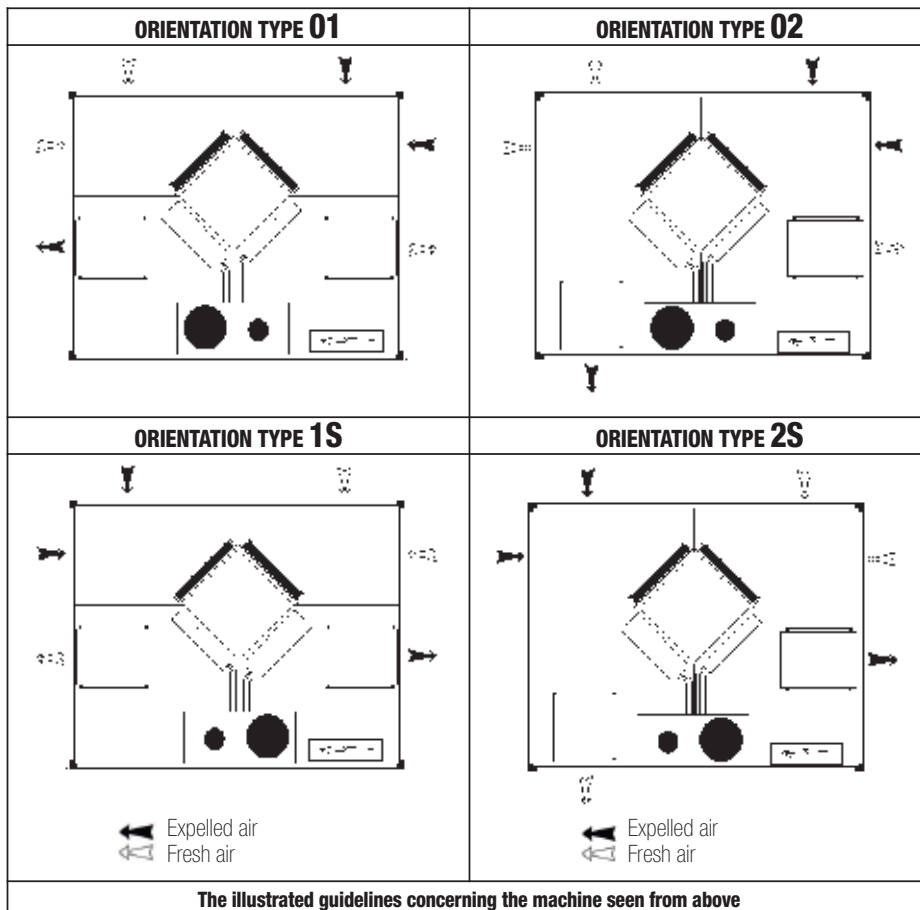

Heat recovery unit

VMC-E 025÷100

Air flow rate: 250÷1,000 m³/h

INVERTER



- Extremely compact
- High efficiency recovery
- Very low noise level
- Brushless DC fans

Fresh air terminal unit with countercurrent flows static heat recovery.

Construction features

- Galvanised sheet steel self-bearing structure, insulated internally and externally.
- Recovery unit: thanks to a high yield static type heat exchanger with counterflows consisting of flat layers of special paper that allow total heat exchange, thereby recovering both sensitive and latent heat. The air flows are kept separate by relevant sealing. Maintenance is easily performed on the heat exchanger and filters thanks to the lateral extraction.
- By-pass motorised system of the recovery unit actuated automatically by the electronic control
- Fresh air and ambient inlet class F7 filters.
- Fans: fresh air inlet and centrifugal expulsion with BRUSHLESS DC motors that allow higher efficiency to be achieved with respect to traditional motors with an energy saving of up to 60%. 3 speed management option.
- Ducting connections with plastic circular fittings.
- Incorporated electrical panel with electronic board to control the free-cooling and fan functions.

Controls

- KCVE: remote panel with ON/OFF function, speed selection and programmable weekly timer. It is suitable for wall mounting installation on "502" electrical boxes.
- KTLCM: infrared remote control to be combined with the KCVE.
- KTCV2: remote panel for wall mounting installation, summer/winter environment temperature control, electrical resistance activation consent (KSBE) and min-med-max speed selection.



- Remote panel KCVE
- Remote control KTLCM
- Remote panel KTCV2

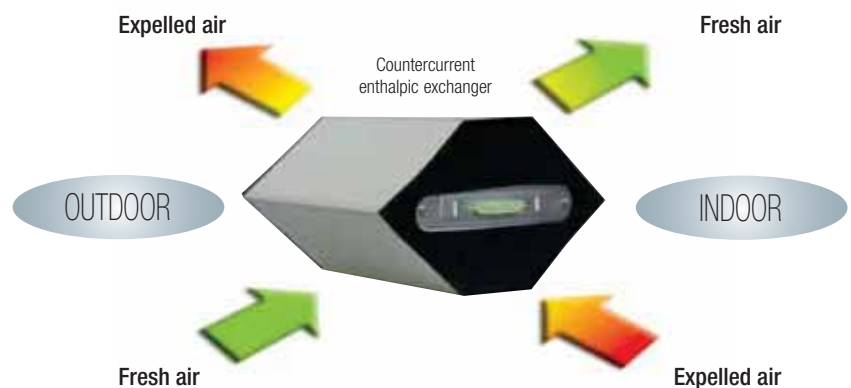



VMC MODEL			25	35	50	80	100	120
Air flow rate	MAX (V)	m ³ /h	260	330	500	750	950	1180
Speed	MED (V)	m ³ /h	260	330	500	660	740	1080
	MIN (V)	m ³ /h	170	250	360	560	600	980
Head Pressure	MAX (V)	Pa	70	70	70	70	70	80
	MED (V)	Pa	70	70	70	50	40	70
Absorbed power	MAX (V)	W	90	120	135	300	310	490
	Speed	MAX (V)	A	1,1	1,4	2,0	2,8	3,0
Int S.F.P.		W/m ³ /s	1043	1032	1178	990	1238	1570
① Sound pressure	MAX (V)	dB(A)	27	31	33	38	39	42
exhaust. Speed	MED (V)	dB(A)	26	29	31	36	37	37
	MIN (V)	dB(A)	22	25	27	32	33	32
Electrical supply		V-ph-Hz	230-1-50	230-1-50	230-1-50	230-1-50	230-1-50	230-1-50
HEAT RECOVERY								
② Winter efficiency (temp/enthalpy)		%	75/61	77/64	77/62	73/59	74/60	71/56
② Winter recovered heating capacity		kW	2,2	3,1	4,3	6,5	8,2	9,1
③ Summer efficiency (temp/enthalpy)		%	62/60	63/61	62,5/60	59/57	59,5/57,5	57/54
③ Summer recovered heating capacity		kW	0,8	1,2	1,7	2,5	3,2	3,7
DIMENSIONS AND WEIGHTS			25	35	50	80	100	120
Length/Depth/Height		mm	885/666/272	885/806/272	970/997/312	1322/882/390	1322/1132/390	1322/1132/390
Weight		Kg	27	32	42	63	76	76

Data at the following conditions:

- ① Values with reference to 1.5 metres from the intake in free field.
- ② Nominal winter conditions: outdoor air: -5°C; 80% UT. Ambient air: 20°C; 50% RH.
- ③ Nominal summer conditions: outdoor air: 32°C; 50% UT. Ambient air: 26°C; 50% RH.

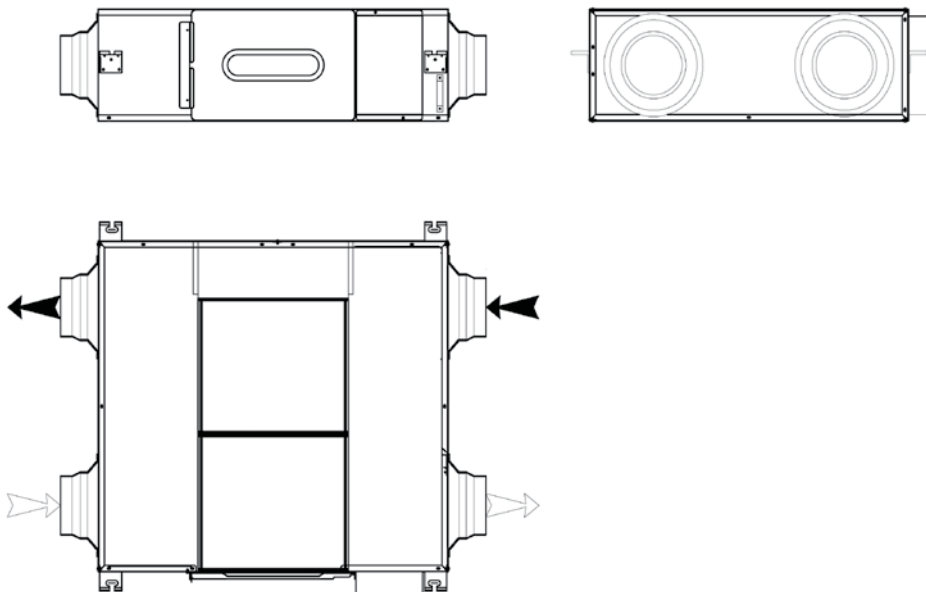



RHOSS S.P.A.

Via Oltre Ferrovia, 32 - 33033 Codroipo (UD) - Italy
tel. +39 0432 911611 - fax +39 0432 911600
rhoss@rhoss.it - www.rhoss.it - www.rhoss.com

IR GROUP SARL

19, chemin de la Plaine - 69390 Vourles - France
tél. +33 (0)4 72 31 86 31 - fax +33 (0)4 72 31 86 30
exportsales@rhoss.it

RHOSS Deutschland GmbH

Hölzlestraße 23, D-72336 Balingen, OT Engstlatt - Germany
tel. +49 (0)7433 260270 - fax +49 (0)7433 260270
info@rhoss.de - www.rhoss.de

RHOSS GULF JLT

Suite No: 3004, Platinum Tower
Jumeirah Lakes Towers, Dubai - UAE
ph. +971 4 44 12 154 - fax +971 4 44 10 581
e-mail: info@rhossulf.com

Italy Sales Departments:

Codroipo (UD)
33033 Via Oltre Ferrovia, 32
tel. +39 0432 911611 - fax +39 0432 911600

Nova Milanese (MB)

20834 Via Venezia, 2 - p. 2
tel. +39 039 6898394 - fax +39 039 6898395

